

EMBRAER 135/145



Crew Awareness

GENERAL

The EMB-145 is provided with a variety of visual, aural, and sensitive warnings to notify crew regarding systems status, malfunctions, and abnormal airplane configurations.

Alarm lights provide indication whether there is an abnormal situation. Some systems also provide indicating lights, for system status indication.

An Engine Indication and Crew Alerting System (EICAS) provides the flight crew with a three-level alerting and indications messages system: warning, caution and advisory. A fourth level is provided exclusively for maintenance purposes. Besides the five displays on the main panel, two back up displays are provided through the RMUs (Radio Management Unit). Some of the more critical messages also generate an aural warning.

Sensitive warning is available through the Stall Protection System (SPS), which shakes the control column, if an imminent stall is detected.

To aid in navigation and approach procedures, the airplane is also provided with a Ground Proximity Warning System (GPWS/EGPWS), a Traffic and Collision Avoidance System (TCAS), and a Windshear Detection and Escape Guidance System.

AVIONICS INTEGRATION

The EMB-145 is equipped with a variety of highly integrated computers and displays, so as to reduce pilots workload while providing high reliability and redundancy. This feature is achieved by providing different paths to each type of data, thus minimizing the possibility of losing information due to failure in one computer.

The system is composed of:

- Two Integrated Computers (IC-600);
- Two Integrated Computer Configuration Modules (IM-600) (If installed);
- Two Data Acquisition Units (DAU);
- One Central Maintenance Computer (CMC);
- One Horizontal Stabilizer Control Unit (HSCU);
- Two Primary Flight Displays (PFD), two Multi-Function Display (MFD) and one Engine Indications and Crew Alerting System (EICAS) display;
- Two Radio Management Units (RMU);

MAIN PANEL

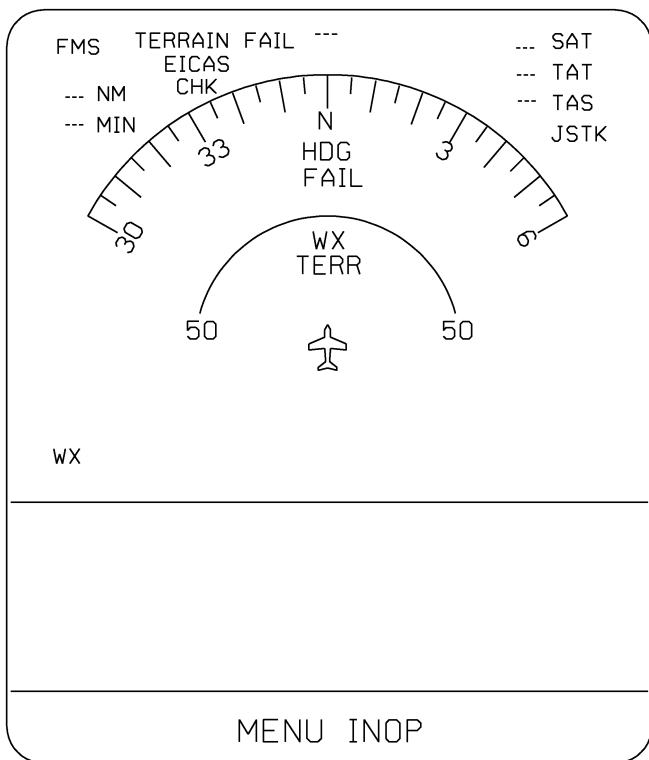
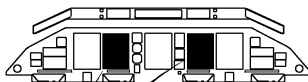

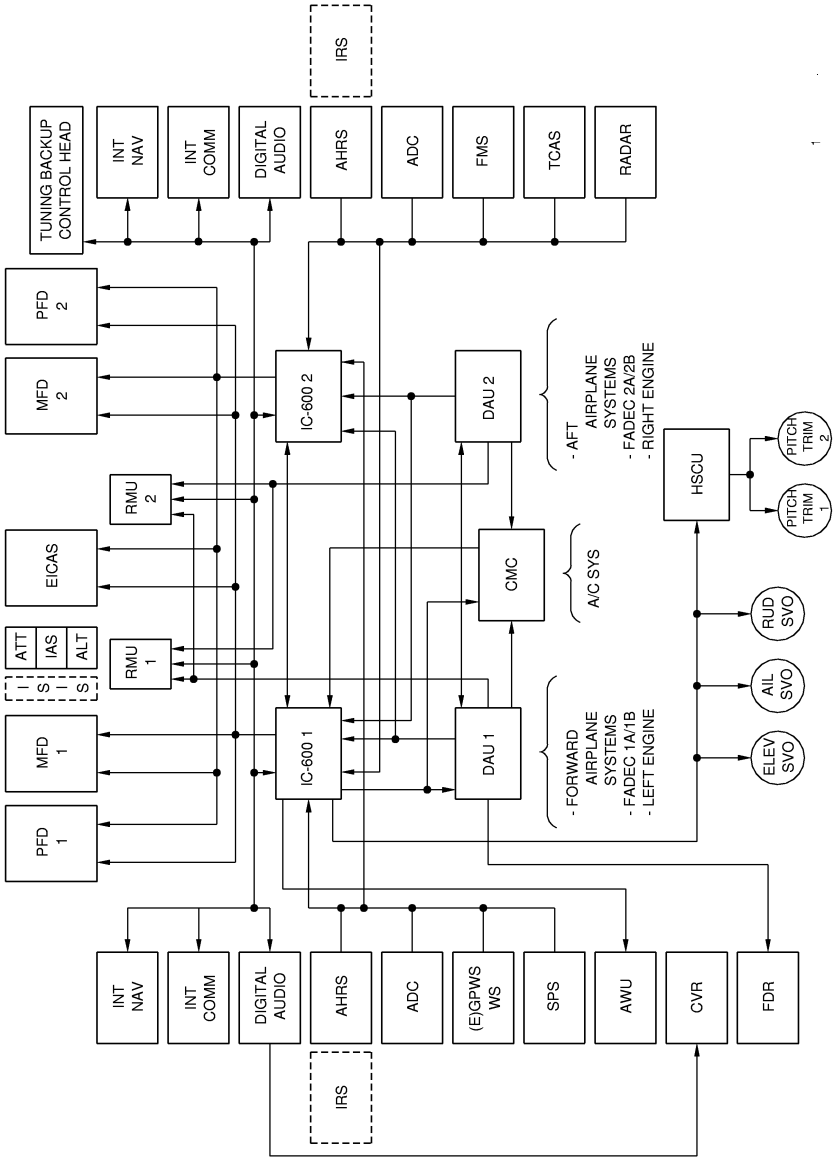

AVIONICS INTEGRATION SCHEMATIC

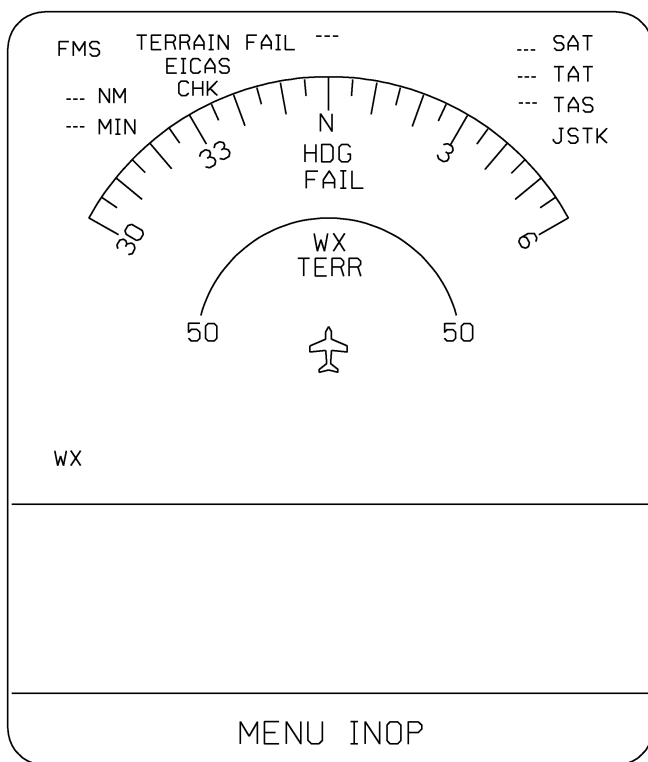
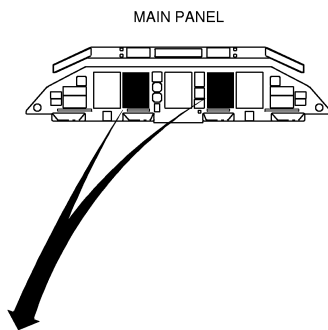

MFD TEST INDICATIONS

DISPLAYS

Five Cathode Ray Tube (CRT) displays are provided to present information to the flight crew, as follows:

- Two Primary Flight Displays (PFD) on the pilot and copilot panel.
- Two Multi-Function Displays (MFD) on the pilot and copilot panel.
- One EICAS display on the center panel.

In addition, the Radio Management Unit (RMU) displays on the control pedestal forward panel may be used as a back-up for the main panel displays.

The displays themselves are identical and interchangeable. The control panel installed just below each display, except for the RMUs, allows controlling some of the associated display features.

In case of failure of one display, its information may be presented in one of the remaining operative displays.

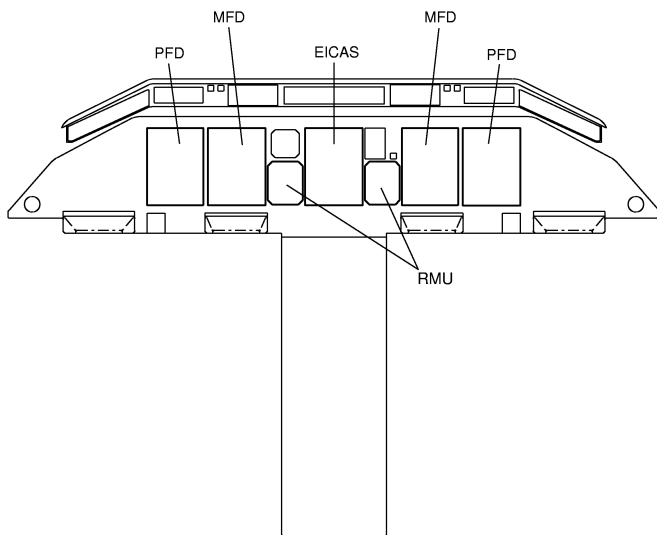

OR

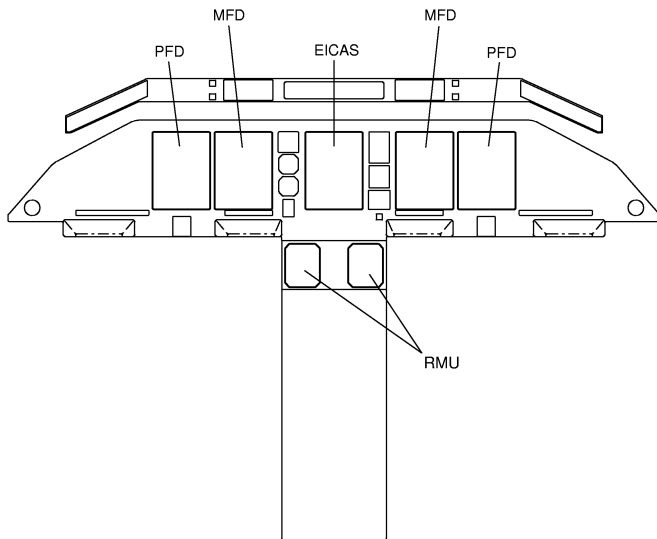

AIRPLANE DISPLAYS

PRIMARY FLIGHT DISPLAY (PFD)

The PFD is the primary pilots instrument. It presents the information formerly presented in a variety of instruments such as airspeed indicator, altitude indicator, ADI, HSI, vertical speed indicator. The PFD further provides radio aids, autopilot, flight director, yaw damper and radio altitude information. For further information on these parameters, refer to Sections 2-17 – Flight Instruments, 2-18 – Navigation and Communication, and 2-19 – Autopilot.

The PFD is divided into sections, each one presenting one group of information.

The PFD bezel incorporates an inclinometer, buttons and a knob for barometric settings.

In case of a display failure, information may be presented on the MFD by appropriately setting the MFD selector knob on the reversionary panel.

The RMU is also able to present PFD information (refer to Section 2-18 - Navigation and Communication for further details about this feature).

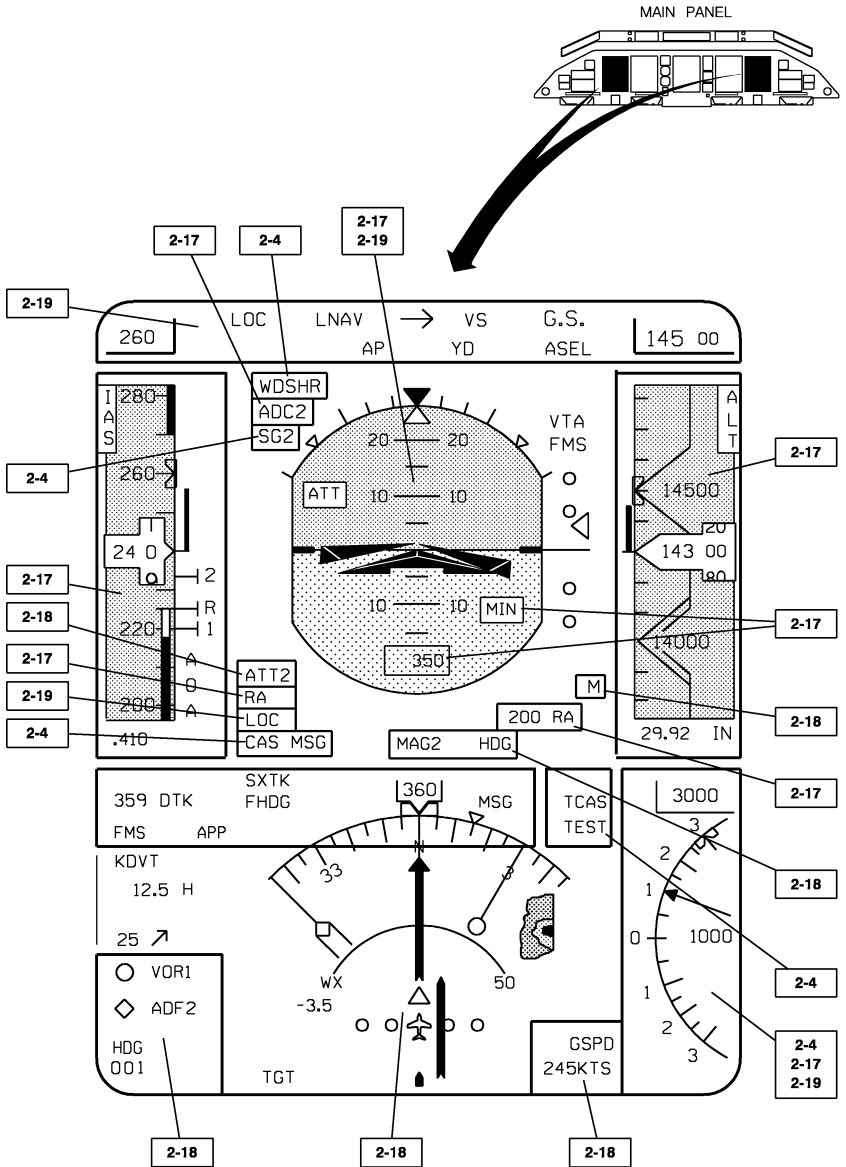

NOTE: Number inside boxes refer to Operations Manual Section where information concerning the associated item can be found.

PFD DISPLAY SCHEMATIC

MULTI FUNCTION DISPLAY (MFD)

The Multi Function Display (MFD) presents radar, TCAS, FMS, CMC and other navigation information and systems pages. There are five system pages available:

- Fuel: provides fuel system parameters and status.
- Electrical: provides electrical system parameters and status.
- Environmental and Ice Protection: provides air conditioning, pneumatics, oxygen, and ice and rain protection systems parameters and status.
- Hydraulic and Brakes: provides hydraulic and brakes systems and status.
- Takeoff: provides takeoff temperature settings, oil level and doors status.

For further information on system pages, refer to each associated system description.

The MFD may operate in three different presentation modes, besides the reversionary ones. The Map and Plan modes present navigation information. For further information on these, refer to Section 2-18 - Navigation and Communication. The maintenance mode permits access to maintenance messages, but is available only on the left MFD for maintenance personnel when the airplane is on ground.

Selection of the different modes and pages may be made by using the controls located on the display bezel. Button functions are indicated in the menus presented in the lower part of the display, just above each button. Each button function changes, depending on which menu has been selected. Menu selection is made by using the buttons themselves. If required, radar modes and TCAS information may be shown.

The MFD also operates as a back-up display for either PFD or EICAS, in case of such displays failure. Appropriate selections may be made through the reversionary panel.

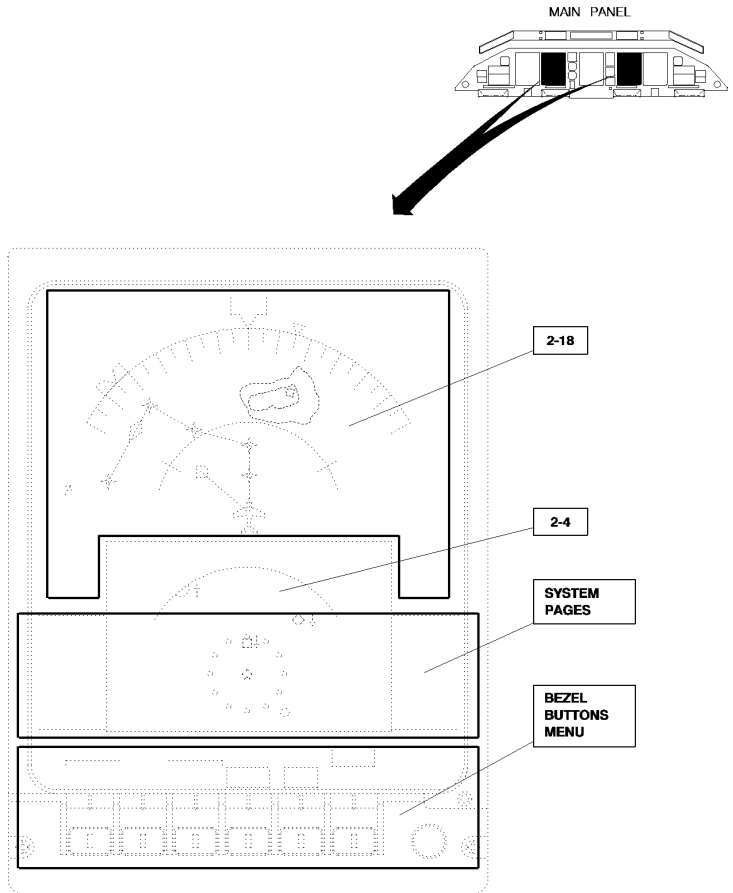

NOTE: Number inside boxes refer to Operations Manual Section where information concerning the associated item can be found.

MFD DISPLAY SCHEMATIC

EICAS DISPLAY

The EICAS display presents analogic engine indications and some systems parameters like flaps, landing gear, spoilers and trim positions, total fuel quantity, APU and environmental information.

In the upper right corner, the EICAS display presents crew awareness messages:

- Warning messages, red colored and always presented on the top of the list.
- Caution messages, amber colored and presented after warning messages.
- Advisory messages, cyan colored and presented after caution messages.

For further information on engine indications presented in the upper left corner, refer to Section 2-10 – Powerplant. For information on EICAS Messages, refer to the item Visual Warnings (Section 2-04-10).

In case of failure in the EICAS display, its information may be presented on the MFD, by appropriately setting the MFD selector knob on the reversionary panel. The RMU is also capable of presenting some EICAS information, should the need arise.

The EICAS bezel is provided with a knob to scroll messages if the system generates more messages than the display can present at once.

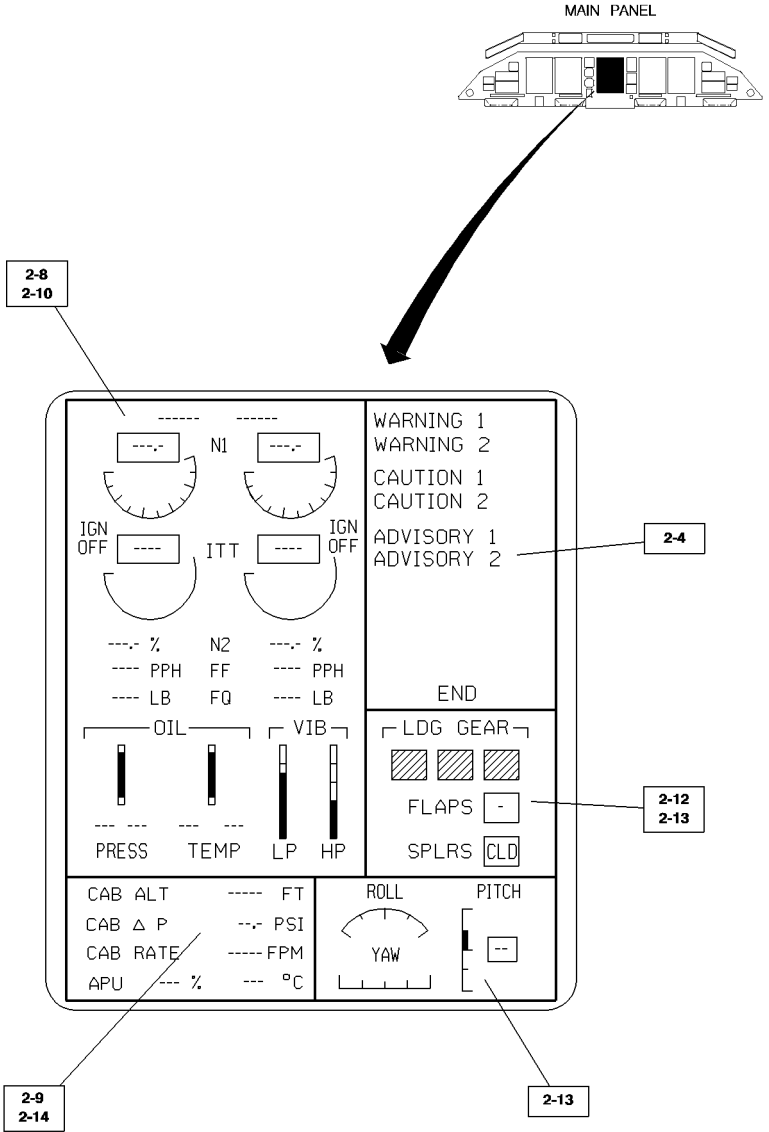

NOTE: Number inside boxes refer to Operations Manual Section where information concerning associated item can be found.

EICAS DISPLAY SCHEMATIC

RADIO MANAGEMENT UNIT

The Radio Management Unit (RMU) is provided for radio controlling purposes, but may be used as a back-up for PFDs, MFDs and EICAS. The RMU display presents settings and modes for each radio (NAV and COMM), transponder, and TCAS. In case of failure of the main panel displays, the RMU may be selected to present navigation, engine or systems information, as well as some EICAS messages. The information presentation however may change, due to the size of the RMU display. Also, some items of information may not be presented to avoid display overload. For further information on RMU features, refer to Section 2-18 – Navigation and Communication.

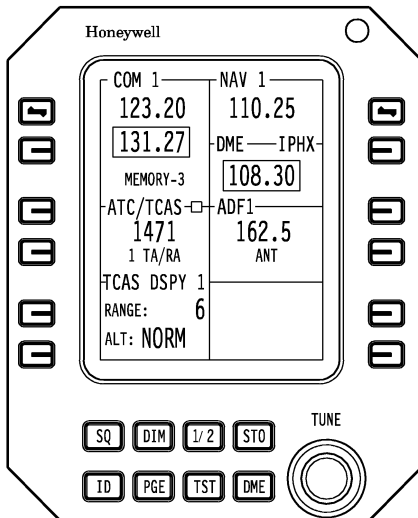
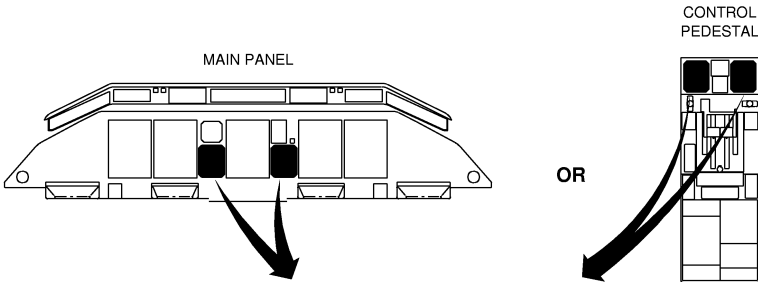

RMU DISPLAY EXAMPLE

NORMAL OPERATION

When the airplane is first energized, the system performs a self-test to check abnormal conditions in the displays.

On power up, the displays default information are the following:

- PFD: presents EADI, EHSI, airspeed, altitude, radio altitude, vertical speed scales, flight director mode, autopilot and yaw damper status.
- MFD: presents takeoff page, system menu and navigation data in Map format. This information is supplied as follows:
 - MFD 1: supplied by channel A of both DAUs through IC-600 # 1.
 - MFD 2: supplied by channel A of both DAUs through IC-600 # 2.
- EICAS: presents engine and fuel indications, crew awareness messages (if any), landing gear, flaps, spoilers, pressurization, APU and trims status. This information is supplied by channel A of both DAUs through IC-600 # 1.

FAILURE MODES

The system is developed to avoid absence of information in most of the failure combinations.

The failures that may affect the crew awareness system are associated with electrical power supply or computer malfunctions. In both cases, the system architecture is such that only major failures will lead to loss of information presentation. Even in this condition, crew will still have essential data available to safely continue the flight, using standby instruments.

ELECTRICAL SYSTEM FAILURES

Each display is supplied in such a way that in case of failure in one or more electric buses, the remaining buses will still be supplying one or more displays.

This feature is achieved by supplying all displays with four different buses (two DC Buses and two Essential buses). Furthermore, each pair of duplicated displays (PFDs, MFDs, and RMUs) are supplied by different buses, one for each display.

COMPUTER FAILURES

Since both IC-600s receive data from duplicated sources, a single failure will not lead to loss of information addressed to the flight crew. In case of any source failure, the reversionary panel permits shifting between existing sources, thus using cross side information. This feature may be used only when the system is not capable of providing information through normal means.

DISPLAYS FAILURES

In case of any failure in the PFD or EICAS displays, the corresponding information may be presented in one of the remaining displays, by using the reversionary panel. The MFD may present other display information, but its data may not be presented in the remaining displays. If all displays are lost, the RMU is capable of providing essential flight data.

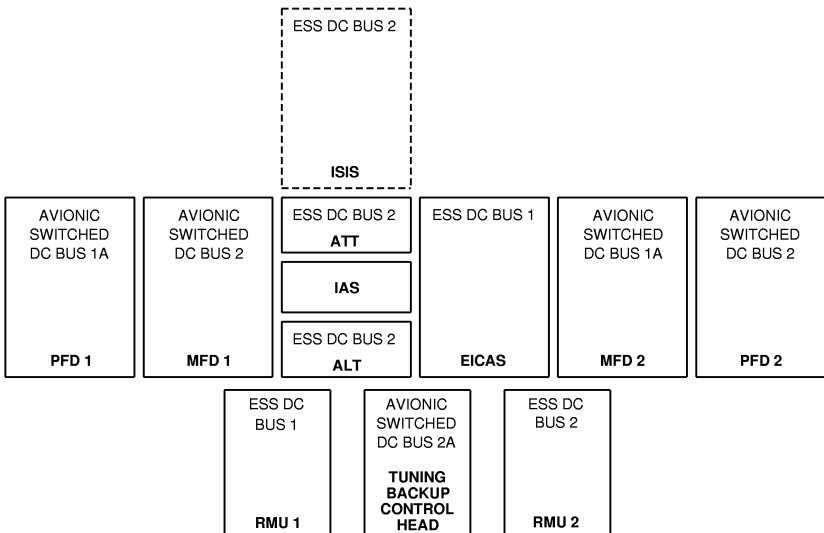

DISPLAYS SUPPLYING SCHEMATIC

EICAS MESSAGES

TYPE	MESSAGE	MEANING
CAUTION	DAU 1 (2) ENG MISCAMP	N1, N2, ITT engine parameters read from both engines are not matching.
	DAU 1 (2) SYS MISCAMP	Systems parameters for system pages generation are not matching.
	DAU 1 (2) WRN MISCAMP	Discrete signals for warning messages generation read from the many systems are not matching.
	DAU 1 (2) A FAIL	Associated DAU channel A has failed.
	DAU AC ID MISCAMP	Mismatch between DAU 1 and DAU 2 configuration inputs regarding aircraft type.
	IC 1 (2) OVERHEAT	Associated temperature of the IC-600 is too high.
	IC BUS FAIL	A failure in the Interconnection Bus has been detected.
	IC 1 (2) WOW INOP	ICs/Weight - On - Wheels interface not working properly.
	CHECK PFD 1 (2)	A miscomparison on the associated PFD bus has been detected.
	CHECK IC 1 (2) SW	Updating error on IC-600.
CHK IC CONFIG	Configuration module mismatch (airplane model, engine type, LR version, and units).	

(Continued)

(Continued)

TYPE	MESSAGE	MEANING
ADVISORY	CONFIG MISMATCH (if applicable)	For EICAS 16, means mismatch of any configuration between both IM-600s. For EICAS 16.5 or later, means mismatch of any of the configurations stored in the IM-600 modules except those considered in the CHK IC CONFIG logic.
	DAU 1 (2) B FAIL	Associated DAU channel B has failed.
	DAU 1 (2) REVERSION	Associated DAU has been commanded to operate with channel B mode.
	CMC FAIL	CMC has failed.
	IC 1 (2) CONFIG FAIL	A failure in the configuration module of the IC has been detected.
	DU 1 (2, 3, 4, 5) FAN FAIL	Associated display fan has failed.
	DU 1 (2, 3, 4, 5) OVHT	Associated display unit temperature is too high.
	IC 1 (2) FAN FAIL	Associated IC fan has failed.

CONTROLS AND INDICATORS

PFD BEZEL

Provides controls that allow barometric settings in the PFD. For further information, refer to Section 2-17 - Flight Instruments.

MFD BEZEL

MAIN MENU

1 - SYSTEM BUTTON

- Selects system menu.
- If TCAS window is being displayed, it will be replaced by the previously selected system page.

2 - MFD BUTTON

- Selects MFD menu.

3 - CHECKLIST BUTTON

- This function is not enabled.

4 - TCAS BUTTON

- Selects TCAS information to be presented on the MFD. For further information refer to item TCAS presented in this section.
- If TCAS is already selected, pressing the button restores the previously selected system page.

5 - WEATHER RADAR BUTTON

- Selects weather radar information to be presented on the MFD. For further information on weather radar, refer to Section 2-18 - Navigation and Communication.

6 - MAP PLAN BUTTON

- When the radar is being displayed, enables the Map format for radar presentation. For further information on weather radar, refer to Section 2-18 – Navigation and Communication.

7 - MAP/PLAN RANGE KNOB

- Allows setting the Map format range that is displayed on the MFD. For further information on this feature, refer to Section 2-18 – Navigation and Communication.
- Except for the SPDS menu, this knob function is available in all menus.

SYS SUBMENU

1 - RETURN BUTTON

- Returns to the main menu.

2 - TAKEOFF PAGE BUTTON

- Selects the takeoff page to be presented on the MFD. For further information on this page refer to Section 2-2 – Equipment and Furnishings and Section 2-10 – Powerplant.

3 - ENVIRONMENTAL CONTROL SYSTEM AND PNEUMATIC PAGE BUTTON

- Selects the environmental control system and pneumatic page to be presented on the MFD. For further information on this page refer to Sections 2-14 – Pneumatics, Air Conditioning and Pressurization and Section 2-16 – Oxygen.

4 - FUEL SYSTEM PAGE BUTTON

- Selects the fuel system page to be presented on the MFD.
- When fuel system page is being displayed, button function changes.
- For further information on this page refer to Section 2-8 – Fuel.

5 - HYDRAULIC PAGE BUTTON

- Selects the hydraulic page to be presented on the MFD. For further information on this page refer to Section 2-11– Hydraulic.

6 - ELECTRICAL SYSTEM PAGE BUTTON

- Selects the electrical system page to be presented on the MFD. For further information on this page refer to Section 2-5 – Electrical.

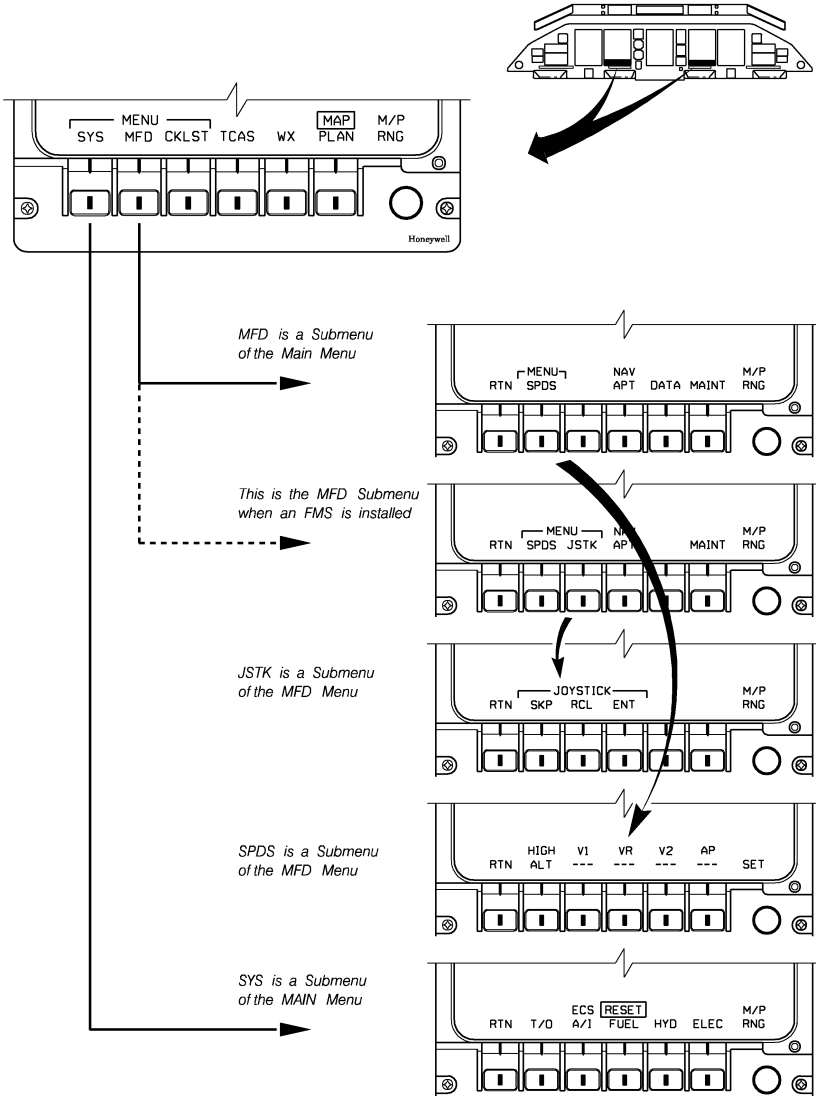

MFD BEZEL BUTTON MENU TREE

MFD SUBMENU

- 1 - RETURN BUTTON
 - Returns to the main menu.
- 2 - REFERENCE SPEEDS BUTTON
 - Selects SPDS menu. For further information on this menu, refer to Section 2-17 – Flight Instruments.
- 3 - JOYSTICK BUTTON
 - **NOTE:** This function is available only when the FMS is installed.
 - Selects JSTK menu. For further information on this menu, refer to Section 2-18 – Navigation and Communication.
- 4 - AIRPORT AND NAVIGATION AIDS BUTTON
 - Provides selection and toggling of airport and navigation aids displays on the MFD. For further information on this feature, refer to Section 2-18 – Navigation and Communication.
- 5 - DATA BUTTON
 - Provides selection and toggling of waypoint identifier displays on the MFD. For further information on this feature, refer to Section 2-18 – Navigation and Communication.
- 6 - MAINTENANCE SELECTION BUTTON (LEFT MFD ONLY)
 - Presents maintenance messages on MFD.
 - Function is available only on the ground.

EICAS BEZEL

Provides a knob to allow EICAS messages scrolling. For further information, refer to Visual Warnings in this Section.

REVERSIONARY PANEL

1 - MFD SELECTOR KNOB

PFD - presents on the MFD the information normally presented on the PFD. The PFD bezel button remains their normal function.

NORMAL - Normal MFD operation mode.

EICAS - presents on the MFD the information normally presented on the EICAS.

2 - ADC BUTTON

- Changes the ADC information from the on-side ADC to the cross-side ADC.
- A striped bar illuminates inside the button to indicate that it is pressed.

3 - AHRS/IRS BUTTON

- Changes the attitude and heading source from the on-side AHRS/IRS to the cross-side AHRS/IRS.
- A striped bar illuminates inside the button to indicate that it is pressed.

4 - SYMBOL GENERATOR BUTTON

- Changes the symbol generator from the on-side SG to the cross-side Symbol Generator as well ADC and AHRS.
- A striped bar illuminates inside the button to indicate that it is pressed.

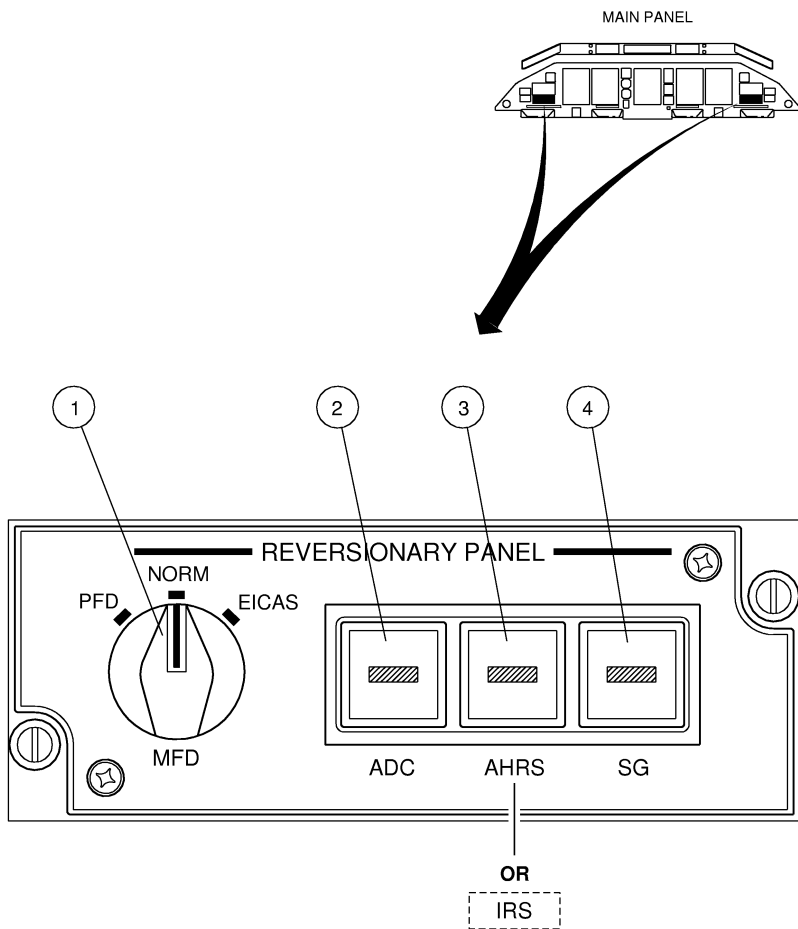

REVERSIONARY PANEL

EICAS REVERSIONARY PANEL

1 - DAU REVERSIONARY BUTTON

- Allows channel B of associated DAU to supply both IC-600s.
- A striped bar is illuminated inside the button to indicate that it is pressed and that channel B is the current data source.

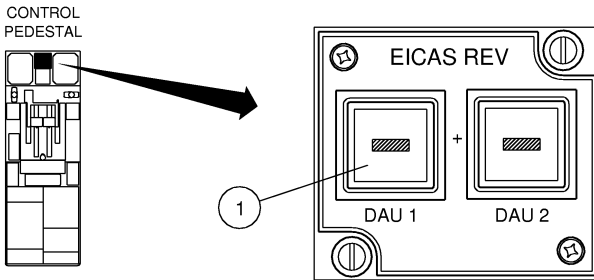

OR

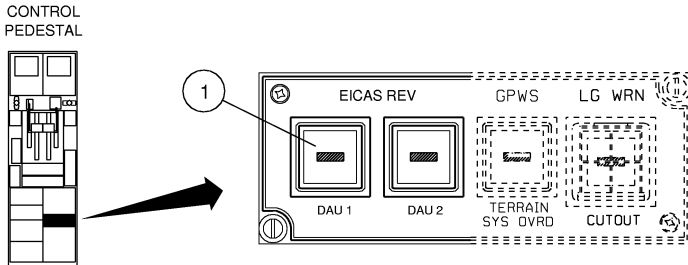

EICAS REVERSIONARY PANEL

PRIMARY FLIGHT DISPLAY

1 - SYMBOL GENERATOR REVERSION ANNUNCIATION

- Indicates that a symbol generator reversion has been selected on the reversionary panel.
- Presented on both PFDs.
- Labels: SG1 for IC-600 # 1 and SG2 for IC-600 # 2.
- Color: amber

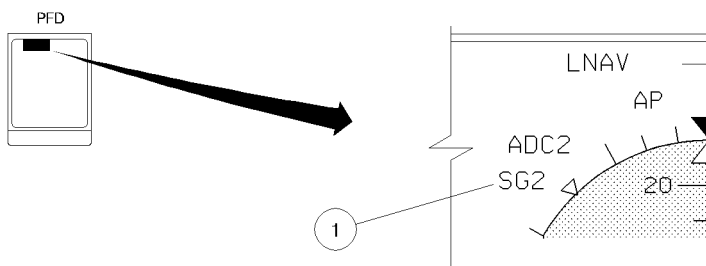

PRIMARY FLIGHT DISPLAY

DISPLAYS CONTROL PANEL

NOTE: For further information on displays control panel, refer to Sections 2-17 – Flight Instruments and 2-18 – Navigation and Communication .

1 - TEST BUTTON

- On the ground:
 - When pressed, activates the IC-600s first level test.
 - When pressed for more than 6 seconds activates the IC 600s second level test.
 - When released, normal operation of IC-600s is resumed.

- In flight:

Refer to Radio Altimeter description on Section 2-17 – Flight Instruments.

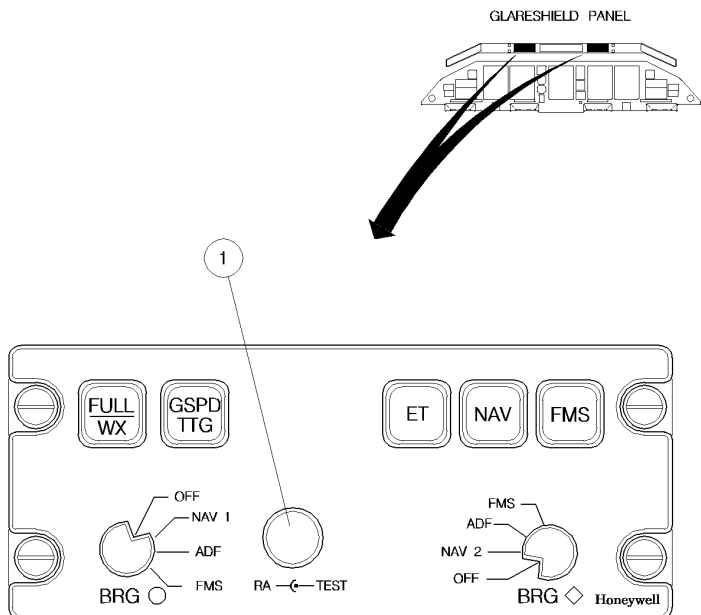

DISPLAYS CONTROL PANEL

BUILT-IN TEST

There are 3 kinds of Built-In-Tests (BIT) that the IC-600 may perform: power up BIT, continuous BIT and pilot initiated BIT. All of them check the software and hardware integrity and operation.

POWER UP BIT

The power up BIT checks the power supply, IC-600 interfaces, memories, autopilot engagement and disengagement, and autopilot servos.

CONTINUOUS BIT

Memories and processors tests are continuously performed after the power up BIT, as well as autopilot functions.

PILOT INITIATED BIT

A pilot initiated BIT may be commanded by pressing the TEST button in the displays control panel. This test may be commanded on the ground only and is divided into two levels. The first level is indicated on airplane displays, which present the failure mode annunciations.

The second level is activated if the TEST button is held pressed, and checks the IC-600 internal interfaces. The test results are displayed on the PFD, which alternates every 10 seconds between internal and external test results pages.

To perform the IC-600 test is necessary to press the TEST button at co-localized display control panel.

The PFD first level test indications are as follows:

- A magenta TEST is displayed in upper left center of the PFD.
- Indications removed: all bugs, flight director information, all pointers, low airspeed awareness, take-off speed bugs and digital readouts, V_{MO}/M_{MO} , and trend vectors.
- Indications forced: all comparison monitors, all marker beacons, and windshear annunciation.
- Indications presented as invalid: pitch and roll, vertical and lateral deviations, baro correction, vertical speed set digital readout, altitude preselect, heading, distance digital readout, ground speed (or time to go or elapsed time), selected heading and course (or desired track), Mach, airspeed, airspeed set digital readout, altitude.
- If heading is valid upon test activation, its source annunciation will remain valid (DG1 or 2 or MAG1 or 2). If heading is invalid, its source annunciation will change to HDG1 or HDG2.

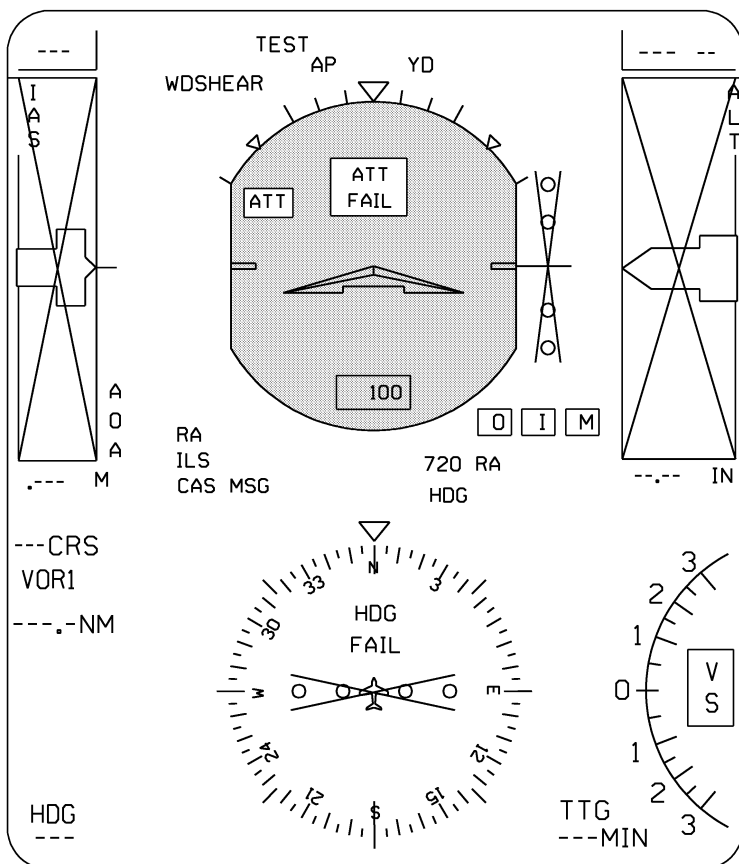
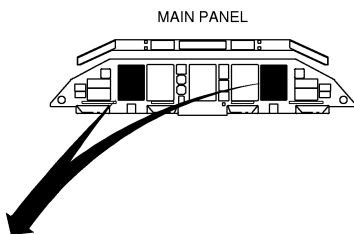

PFD TEST INDICATIONS - FIRST LEVEL

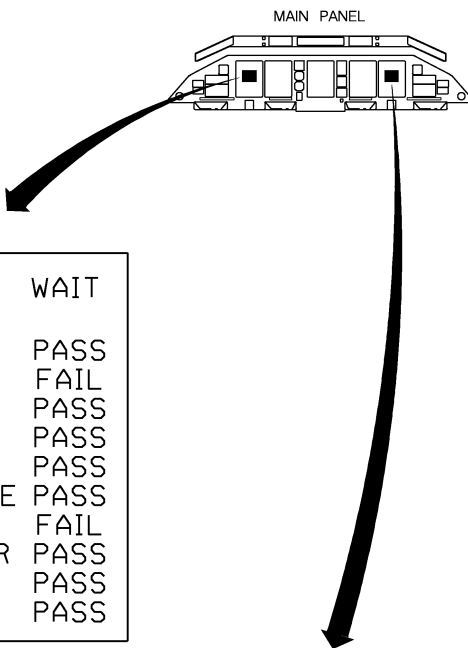

IC-600	IBIT	WAIT
FLIGHT AUTOPILOT		PASS
FLIGHT DIRECTOR		FAIL
SYMBOL GENERATOR		PASS
DYSPLAY UNIT		PASS
ATT/HDG INTERFACE		PASS
RADIO ALT INTERFACE		PASS
RADIO INTERFACE		FAIL
DYSPLAY CONTROLLER		PASS
LAMP DRIVERS		PASS
ADC DATA		PASS

IC-600	IBIT	WAIT
FLIGHT DIRECTOR		FAIL
SYMBOL GENERATOR		PASS
DYSPLAY UNIT		PASS
ATT/HDG INTERFACE		PASS
RADIO ALT INTERFACE		PASS
RADIO INTERFACE		FAIL
DYSPLAY CONTROLLER		PASS
LAMP DRIVERS		PASS
ADC DATA		PASS

PFD TEST INDICATIONS - SECOND LEVEL

The MFD test indications are as follows:

- Indications removed: heading source, TCAS, weather patch, drift bug, wind vector, heading select bug, flight plan data, airports, nav aids, designator information.
- Indications forced: TERRAIN FAIL, EICAS CHK, WX TERRAIN, MENU INOP, HDG FAIL.
- Indications presented as invalid: heading, weather radar tilt, SAT, true airspeed, ground speed, distance and time to waypoint.

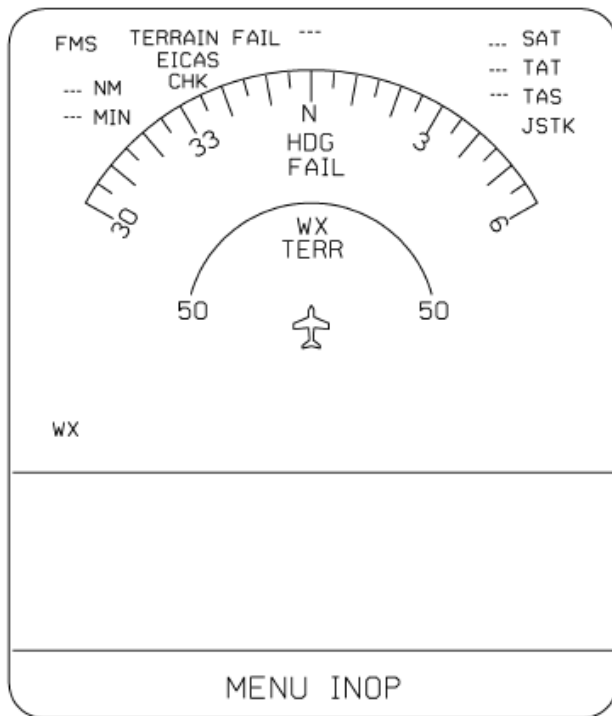

MFD TEST INDICATIONS

The EICAS test is commanded only from the pilot's panel, and its indications are as follows:

- Indications removed: reversion, ignition, FADEC in control, all engine and trim bugs.
- Indications forced: the crew awareness field will be filled with a "X".
- Indications presented as invalid: landing gear status, N1, N2, ITT, fuel flow and quantity, oil pressure, temperature and quantity, vibration for LP and HP, flaps, spoilers, all cabin and APU parameters, all trim values.

During IC-600 # 1 first level pilot initiated BIT, RMU 1 will display the first page of standby engine indication. The RMU 2 is not included in the IC-600 # 2 first level pilot initiated BIT.

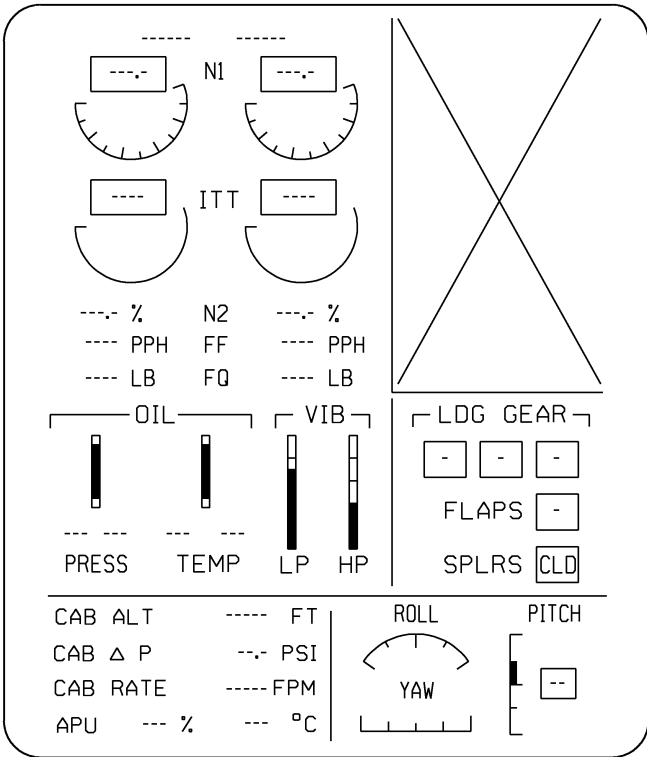
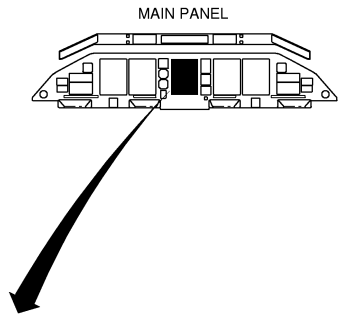

EICAS TEST INDICATIONS

VISUAL WARNINGS

Visual warnings are provided through lights, illuminated buttons, EICAS messages and displays indications.

WARNING LIGHTS

Some of the airplane systems are actuated by illuminated buttons. When under normal operating conditions, such buttons are not illuminated. If the pilot has commanded the button to a position that requires crew attention, a striped bar is illuminated inside the button. There are some exceptions such as the windshield heating, the GPU, the ice protection wing and stab, and the APU bleed buttons, which are illuminated under normal operating conditions.

Some systems also provide indicating lights, for system status indication. Further details on such lights are provided in the associated systems description section.

Master warning and caution lights are installed on each pilot glareshield panel. Such lights blink when any warning or caution message is presented on the EICAS or generated in the Aural Warning Unit (AWU). To stop blinking, pilots must press the associated light. To find information on illuminated buttons and any specific warning light, refer to the associated system's description.

EICAS MESSAGES

EICAS messages are presented in the upper right corner of the EICAS display. In case of a simultaneous failure in the EICAS and MFD displays, the RMUs are capable of presenting some messages.

EICAS MESSAGES LEVELS

There are three message levels: warning, caution, and advisory:

- **Warning** messages are red colored and require immediate crew action. Warning messages are always presented on the top of the list, in the same order they are generated.
- **Caution** messages are amber colored and require immediate crew awareness. They follow warning in criticality level and in display presentation.
- **Advisory** messages are cyan and are dedicated to minor failures or system status. Advisory messages are displayed below caution messages.

A fourth level is provided for maintenance purposes, but it is not presented to the flight crew, and its access can only be made on the ground.

When the message is generated, it is displayed blinking at the top of the associated group. To stop blinking, press the associated master button on the glareshield. Advisory messages will stop blinking after 5 seconds.

EICAS MESSAGES PRIORITY LOGIC

If more than one message is simultaneously presented, warning will precede caution messages, which will precede advisories. The space is provided for the simultaneous display of up to 15 messages. An END label is provided after the last message, to indicate end of message listing. If more than 15 messages are being generated, a knob in the display bezel permits paging through the remaining messages. In this case, a status line is provided in the sixteenth line, to indicate how many messages are not being currently presented and where they are (above or below the currently presented messages). END label and warning messages can not be scrolled out of the display. Due to this characteristic, caution and advisory messages will be scrolled in the area left blank below the warning messages. If a new message is generated during a scrolling, it will be automatically displayed at the top of the associated group.

INHIBITION LOGIC

To avoid its nuisance effect upon the flight crew, inhibition logic is provided to prevent some messages from being displayed during takeoff and approach/landing phases. The inhibition logic is as follows:

Takeoff Phase:

Inhibition is valid when the airplane crosses $V_1 - 15$ kt. The inhibition is deactivated when one of the following conditions is accomplished:

- radio altitude is greater than 400 ft or;
- calibrated airspeed is less than 60 kt or;
- after 1 minute.

Approach/landing Phase:

Inhibition is valid from the point when airplane crosses 200 ft radio altitude. The inhibition is deactivated when one of the following conditions is accomplished:

- airplane is on the ground for 3 seconds or more;
- after 1 minute.

IC-600 RESULTS SELF-CHECK

The results of both IC-600 computations are continuously compared to check for any inconsistency between both sides. A dedicated amber annunciation, “CAS MSG”, is provided on the PFDs to indicate whenever a difference between both IC-600s has been found, thus leading to possible unreliable messages.

EICAS MESSAGE DICTIONARY

The following table presents all the EICAS messages. Type column indicates whether the message's nature is Warning (W), Caution (C), or Advisory (A).

The number in column INHIBITION indicates the following:

- (1) Message is inhibited during takeoff;
- (2) Message is inhibited during takeoff and approach/landing;
- (3) Message is not inhibited;
- (4) Message is inhibited during approach/landing;
- (5) Message is inhibited on the ground and on all flight phases excluding takeoff.

For further information regarding each message's logic, refer to the associated system's description.

SECTION	TYPE		INHIBITION
		MESSAGE	
2-2 EQUIPMENT AND FURNISHINGS	W	MAIN DOOR OPN	2
	W	SERVICE DOOR OPN	2
	C	ACCESS DOORS OPN	2
	C	BAGGAGE DOOR OPN	2
	C	EMERG EXIT OPN	2
	C	FUELING DOOR OPN	2
2-4 CREW AWARENESS	W	GPWS	3
	W	NO TAKEOFF CONFIG	4
	W	SPS 1 (2) INOP	3
	C	DAU AC ID MISCMP	2
	C	DAU 1 (2) ENG MISCMP	2
	C	DAU 1 (2) SYS MISCMP	2
	C	DAU 1 (2) WRN MISCMP	2
	C	AURAL WARN FAIL	2
	C	CHECK PFD 1 (2)	2
	C	CHK IC CONFIG	2
	C	CHECK IC 1 (2) SW	2
	A	CONFIG MISMATCH	2
	C	DAU 1 (2) A FAIL	2
	C	GPWS INOP	3
	C	IC 1 (2) OVERHEAT	2
	C	IC BUS FAIL	2
	C	IC 1 (2) WOW INOP	2
	C	SPS ADVANCED	3
	C	STICK PUSHER FAIL	3
	C	WINDSHEAR INOP	3
	A	IC 1 (2) CONFIG FAIL	2
	A	CHECKLIST MISMATCH	2
	A	CMC FAIL	2
	A	DAU 1 (2) B FAIL	2
	A	DAU 1 (2) REVERSION	2
	A	DU 1 (2, 3, 4, 5) FAN FAIL	2
	A	DU 1 (2, 3, 4, 5) OVHT	2
A	IC 1 (2) FAN FAIL	2	
A	SPS/ICE SPEEDS	1	

SECTION	TYPE		INHIBITION
		MESSAGE	
2-5 ELECTRICAL	W	BATT 1 (2) OVTEMP	3
	W	ELEC ESS XFR FAIL	3
	C	115 VAC BUS OFF	2
	C	APU CNTOR CLSD	2
	C	APU GEN OFF BUS	2
	C	APU GEN OVLD	2
	C	BATT 1 (2) OFF BUS	2
	C	BKUP BATT OFF BUS	2
	C	DC BUS 1 (2) OFF	2
	C	ELEC EMERG ABNORM	2
	C	ESS BUS 1 (2) OFF	2
	C	GEN 1 (2, 3, 4) OFF BUS	2
	C	GEN 1 (2, 3, 4) OVLD	2
	C	SHED BUS 1 (2) OFF	2
A	GEN 1 (2, 3, 4) BRG FAIL	2	
2-6 LIGHTING	C	EMERG LT NOT ARMD	2
2-7 FIRE PROTECTION	W	APU FIRE	3
	W	BAGG SMOKE	2
	W	ENG 1 (2) FIRE	3
	W	LAV SMOKE	2
	C	APU EXTBTL INOP	2
	C	APU FIREDET FAIL	2
	C	BAGG EXT BTL INOP	2
	C	E1 (2) EXTBTLA (B) INOP	2
C	E1 (2) FIREDET FAIL	2	
2-8 FUEL	W	FUEL 1 (2) LO LEVEL	2
	W	FUEL XFER CRITICAL	2
	C	APU FUEL LO PRESS	2
	C	APU FUEL SOV INOP	2
	C	E1 (2) FUEL LO PRESS	2
	C	E1 (2) FUEL SOV INOP	2
	C	FUEL IMBALANCE	2
	C	FUEL TANK LO TEMP	2
	C	FUEL XFEED FAIL	2
	C	FUELING DOOR OPN	2
	C	FUEL EQ XFEED OPN	2
	C	FUEL CONFIG DISAG	2

SECTION	TYPE		INHIBITION
		MESSAGE	
2-8 FUEL	C	FUEL VENT OPEN	2
	C	FUEL XFER INOP	2
	C	FUEL XFER OVFLOW	2
	C	XFER ISOL FAIL	2
	C	DEFUEL NOT CLOSED	2
	A	APU FUEL SOV CLSD	2
	A	E 1(2) FUEL SOV CLSD	2
	A	FUEL XFEED OPEN	2
	A	FUEL LR CONFIG	2
2-9 APU	C	APU FAIL	2
	C	APU OIL HI TEMP	2
	C	APU OIL LO PRESS	2
2-10 POWERPLANT	W	ATTCS FAIL	5
	W	E1 (2) ATTCS NO MRGN	2
	W	E1 (2) OIL LOW PRESS	2
	W	E1 (2) LOW N1	2
	W	ENG 1-2 OUT	1
	C	E1 (2) ATS SOV OPN	2
	C	E1 (2) CTL A (B) FAIL	2
	C	E1 (2) CTL FAIL	2
	C	E1 (2) EXCEEDANCE	2
	C	E1 (2) FPMU NO DISP	2
	C	E1 (2) FUEL LO TEMP	2
	C	ENG NO TO DATA	2
	C	ENG REF A/I DISAG	2
	C	ENG1 (2) REV DISAGREE	2
	C	E1 (2) NO DISP	2
	C	ENG 1 (2) OUT	1
	C	FADEC ID NO DISP	2
	C	ENG 1 (2) REV FAIL	2
	C	ENG 1 (2) TLA FAIL	2
	A	CHECK XXX PERF (XXX = A, A1, A1P, A3, A1/3, A1E)	2
	A	E1 (2) SHORT DISP	2
A	E1 (2) ADC DATA FAIL	2	
A	E1 (2) FUEL IMP BYP	2	
A	E1 (2) OIL IMP BYP	2	

SECTION	TYPE		INHIBITION
		MESSAGE	
2-10 POWERPLANT	A	E1 (2) IDL STP FAIL	2
	A	E1 (2) CTL A (B) DEGRAD	2
2-11 HYDRAULIC	C	HYD SYS 1 (2) FAIL	2
	C	HYD SYS 1 (2) OVHT	2
	A	E1 (2) HYD PUMP FAIL	2
	A	E1 (2) HYDSOV CLSD	2
	A	HYD PUMP SELEC OFF	2
	A	HYD1 (2) LO QTY	2
2-12 LANDING GEAR AND BRAKES	W	LG/LEVER DISAGREE	3
	C	BRAKE OVERHEAT	3
	C	BRK INBD INOP	1
	C	BRK OUTBD INOP	1
	C	EMRG BRK LO PRES	1
	C	LG AIR/GND FAIL	3
	C	STEER INOP	2
	C	NLG/UPDOOR OPN	2
	C	BRAKE DEGRADED	1
2-13 FLIGHT CONTROLS	W	PIT TRIM 1 (2) INOP	2
	W	PTRIM MAIN INOP	2
	W	PTRIM BACKUP INOP	2
	C	AIL SYS 1 (2) INOP	2
	C	FLAP FAIL	2
	C	PTRIM CPT SW FAIL	3
	C	PTRIM F/O SW FAIL	3
	C	PTRIM BKP SW FAIL	3
	C	RUDDER OVERBOOST	2
	C	RUDDER SYS 1 (2) INOP	2
	C	RUD HDOV PROT FAIL	2**
	C	SPBK LVR DISAGREE	2
	C	SPOILER FAIL	2
A	FLAP LOW SPEED	2	
2-14 PNEUMATICS, AIR CONDITIONING AND PRESSURIZATION	W	BLD 1 (2) LEAK	2
	W	BLD APU LEAK	2
	W	BLD 1 (2) OVTEMP	2
	C	APU BLD VLV FAIL	2
	C	BLD 1 (2) LOW TEMP	2
	C	BLD 1 (2) VLV FAIL	2

SECTION	TYPE		INHIBITION
		MESSAGE	
2-14 PNEUMATICS, AIR CONDITIONING AND PRESSURIZATION	C	CROSS BLD FAIL	2
	C	CROSS BLD SW OFF	2
	C	ELEKBAY OVTEMP	2
	C	HS VLV 1 (2) FAIL	2
	C	PACK 1 (2) OVHT	2
	C	PACK 1 (2) OVLD	2
	C	PACK 1 (2) VLV FAIL	2
	C	PRESN AUTO FAIL	2
	C	RAM AIR VLV FAIL	2
	A	BLD 1 (2) VLV CLSD	2
	A	HI ALT LDG-T/O	2
	A	CROSS BLD OPEN	2
	A	PACK 1 (2) VLV CLSD	2
2-15 ICE AND RAIN PROTECTION	W	ICE COND-A/I INOP	2
	C	A/ICE SWITCH OFF	2
	C	A/ICE LOW CAPACITY	3
	C	AOA 1 (2) HEAT INOP	2
	C	E1 (2) A/ICE FAIL	2
	C	ENG 1 (2) A/ICE FAIL	2
	C	ICE DET1 (2) FAIL	2
	C	ICE DETECTORS FAIL	2
	C	NO ICE-A/ICE ON	2
	C	PITOT 1 (2, 3) INOP	2
	C	STAB A/ICE FAIL	2
	C	TAT 1 (2) HEAT INOP	2
	C	WG A/ICE ASYMETRY	3
	C	WG 1 (2) A/ICE FAIL	2
	C	WG A/ICE FAIL	3
	C	W/S 1 (2) HEAT FAIL	2
	A	ICE CONDITION	2
A	ENG A/ICE OVERPRES	3	
2-16 OXYGEN	C	OXYGEN LO PRESS	2
2-17 FLIGHT INSTRUMENTS	C	DFDR FAIL	2
	A	FDAU FAIL	2
	A	RAD ALT 1 (2) FAIL	1
	A	RAD ALT FAIL	1

SECTION	TYPE		INHIBITION
		MESSAGE	
2-18 NAVIGATION AND COMMUNICATION	C	AHRS 1 (2) OVERHEAT	2
	C	AHRS 1 (2) ALN FAULT	2
	C	AHRS 1 (2) FAIL	2
	C	IRS 1 (2) OVERHEAT	2
	A	IRS 1 (2) ATT MODE	2
	C	IRS 1 (2) ALN FAULT	2
	C	IRS 1 (2) FAIL	2
	A	AHRS 1 (2) BASIC MODE	2
	A	AHRS 1 (2) ATT MODE	2
	A	AHRS 1 (2) ALN	2
	A	AHRS 1 (2) ON BATT	2
	A	AHRS 1 (2) EXC MOTION	2
	A	IRS 1 (2) ALN	2
	A	IRS 1 (2) ON BATT	2
	A	IRS 1 (2) EXC MOTION	2
	C	HGS FAIL	3
	A	A III NOT AVAIL	3
A	AHRS 1(2) NO PPOS	1	
2-19 AUTOPILOT	W	AUTOPILOT FAIL	2
	C	AUTO TRIM FAIL	2
	C	AP ELEV MISTRIM	2
	C	AP AIL MISTRIM	2
	C	LATERAL MODE OFF	3
	C	VERTICAL MODE OFF	3
	C	YAW DAMPER FAIL	2

DISPLAYS INDICATIONS

Many of the airplane's parameters are indicated on one of the displays, in analogic or digital format.

ANALOGIC INDICATIONS

Analogic indications are provided as pointers moving over a scale, which may be graduated or not. In both cases, if the pointer indicates a value out of the normal range for that parameter, both pointer and scale become amber or red, if the parameter goes deeply into the out of range area. Pointers are removed if the parameter signal becomes invalid. For some parameters, scale may also be removed in this condition. Scale and pointer are not presented for some parameters, when they are not required, as for EADI chevrons, V_1 , V_R , V_2 speed bugs, trend vectors, etc.

DIGITAL INDICATIONS

Digital indications are provided as green characters for normal values. If the associated parameter goes outside its normal range, digits become amber, with an amber box surrounding them. Both digits and box become red if the parameter goes deeply into the out of range area. If the parameter signal becomes invalid, digits are replaced by amber dashes, without boxes.

CONTROLS AND INDICATORS

GLARESHIELD PANEL

1 - MASTER WARNING BUTTON

- Acknowledges the warning messages and stops the associated blinking when pressed.
- A red light blinks inside the button when a new warning message is displayed on the EICAS.

2 - MASTER CAUTION BUTTON

- Acknowledges the caution messages and stops the associated blinking when pressed.
- An amber light blinks inside the button when a new caution message is displayed on the EICAS.

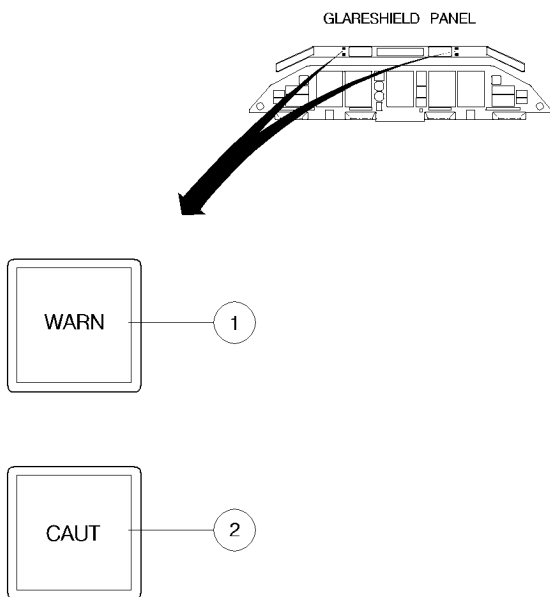

GLARESHIELD PANEL

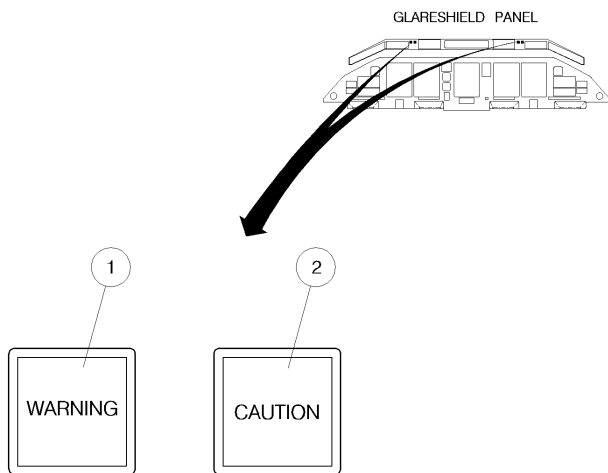

GLARESHIELD PANEL (OPTIONAL)

EICAS BEZEL

1 - MESSAGE SCROLLING KNOB

- To be used when displayed EICAS messages can not be presented at once.
- By rotating the knob clockwise, advances through EICAS messages. Rotated counterclockwise moves backward through EICAS messages.

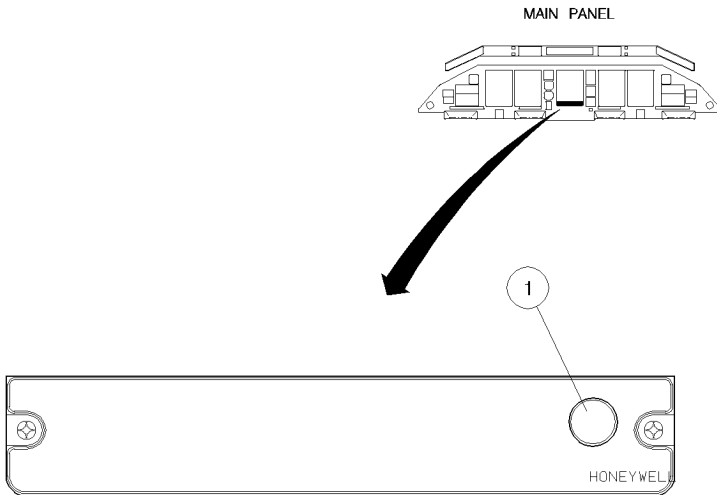

EICAS BEZEL

PRIMARY FLIGHT DISPLAY

1 - EICAS CHECK SUM FAIL COMPARISON MONITOR DISPLAY

- Color: amber.
- Label: CAS MSG.
- Displayed when the number of active EICAS messages in each IC-600 is found to be different.

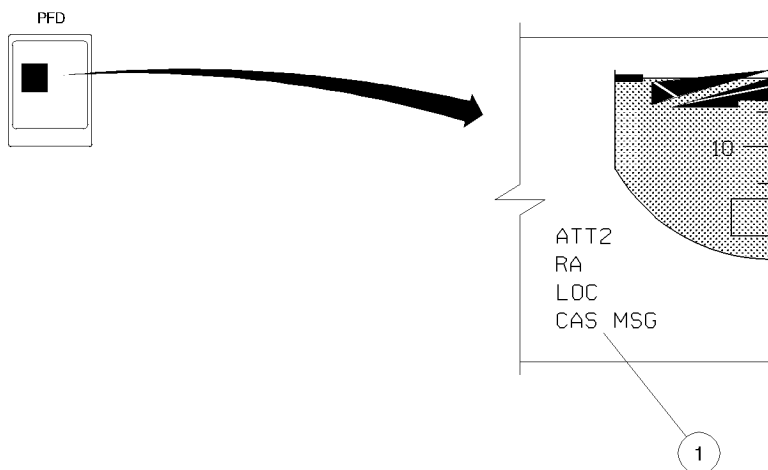

PRIMARY FLIGHT DISPLAY

EICAS DISPLAY

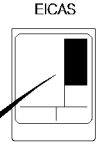

88.1	T/O-1	88.1	BLD1LEAK BLD2LEAK BLDAPULEAK PACK10VLD PACK20VLD BLD1TEMP BLD2TEMP CROSSBLDFAIL BLD1VLVFAIL BLD2VLVFAIL PACK1VLVCLSD PACK2VLVCLSD BLD1VLVCLSD BLD2VLVCLSD 0 ^ MESSAGES ↓ 2
REV 75.0	NI	75.0	
A		A	
IGN	ITT	IGN	
AB 550		AB 550	
99.9%	N2	99.9%	
990PPH	FF	990PPH	
900LB	FQ	1000LB	
OIL		VIB	
7979	100 100	LP	HP
PRESS	TEMP		
		LDG GEAR	
		UP UP UP FLAPS 0 SPLRS CLD	
CAB ALT 7000 FT		ROLL	
CAB Δ P 7.5 PSI			
CAB RATE -2000FPM		PITCH	
APU 100% 600 °C			
		YAW	

- WARNING MESSAGES (RED)
- CAUTION MESSAGES (AMBER)
- ADVISORY MESSAGES (CYAN)
- MESSAGE STATUS LINE (AMBER)

EICAS MESSAGES EXAMPLE

RMU DISPLAY

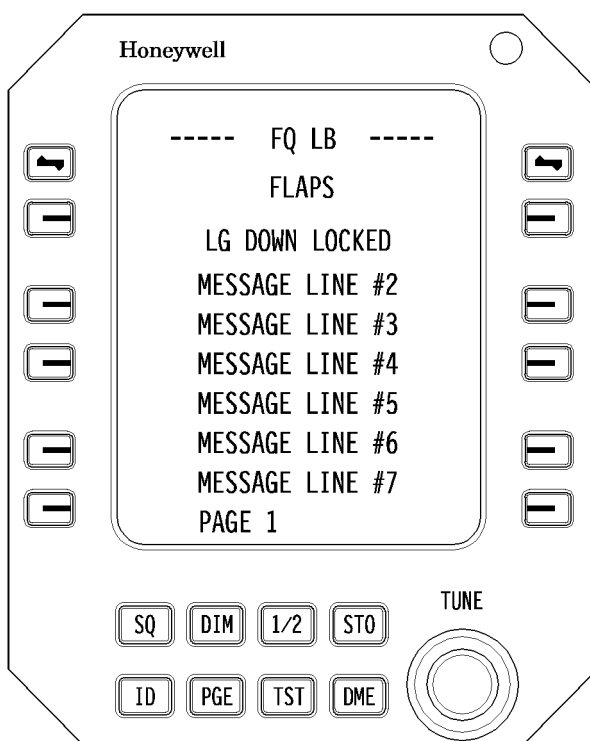

RMU MESSAGES EXAMPLE

PFD PRESENTATIONS

COMPARISON MONITORS

The left and right side area for several critical parameters is monitored by the system. If an excessive difference is detected between left and right side information, a comparison monitor annunciator for data is displayed on the PFD.

Active messages are cleared when the miscompare situation has been corrected.

Comparison monitor annunciators are displayed as follows:

1 - PIT (PITCH ATTITUDE)

- Displayed in the upper left corner of the attitude sphere when pitch attitude data differs by more than $\pm 5^\circ$.

2 - ALT (ALTITUDE)

- Displayed in the upper right corner of the altitude tape when altitude data differs by more than ± 200 ft.

3 - HDG (HEADING)

- Displayed to the upper right of the HSI compass when heading data differs by more than $\pm 6^\circ$ (level flight).

4 - LOC (LOCALIZER)

- Displayed to the lower left of the attitude sphere when localizer deviation differs by more than approximately $\frac{1}{2}$ dot (below 1200 ft AGL).

5 - CAS MSG (CAS MESSAGE)

- Displayed to the lower left of the attitude sphere when a red or amber CAS message has been triggered by the on-side IAC but not the cross-side IAC.

6 - ILS (INSTRUMENT LANDING SYSTEM)

- Displayed to the lower left of the attitude sphere when both localizer and glideslope comparison monitors have been tripped.

7 - GS (GLIDESLOPE)

- Displayed to the lower left of the attitude sphere when glideslope deviation differs by more than approximately 2/3 dot (below 1200 ft AGL).

8 - RA (RADIO ALTITUDE)

- Displayed to the lower left of the attitude sphere when radio altitude data differs by more than the amount calculated by the formula $[(RA1+RA2) \times 0.0625] + 10$. Available only with two radio altimeters installed.

9 - IAS (AIRSPEED)

- If the on-side and cross-side calibrated airspeed differ by 5 kt or more for longer than 2 seconds, it is displayed in the upper left corner of the airspeed tape first flashing, for 10 seconds, and then steady.

10 - ROL (ROLL ATTITUDE)

- Displayed in the upper left corner of the attitude sphere when roll attitude data differs by more than $\pm 6^\circ$.

11 - ATT (ATTITUDE)

- Displayed in the upper left corner of the attitude sphere when both pitch and roll comparison monitors have been tripped.

NOTE: The comparison monitor is active when the pilot and copilot have the same type of data, but different sources selected for display. For example, if the pilot and copilot both have ILS 1 selected (amber source annunciator), no comparison monitor is active on that data (localizer and glideslope).

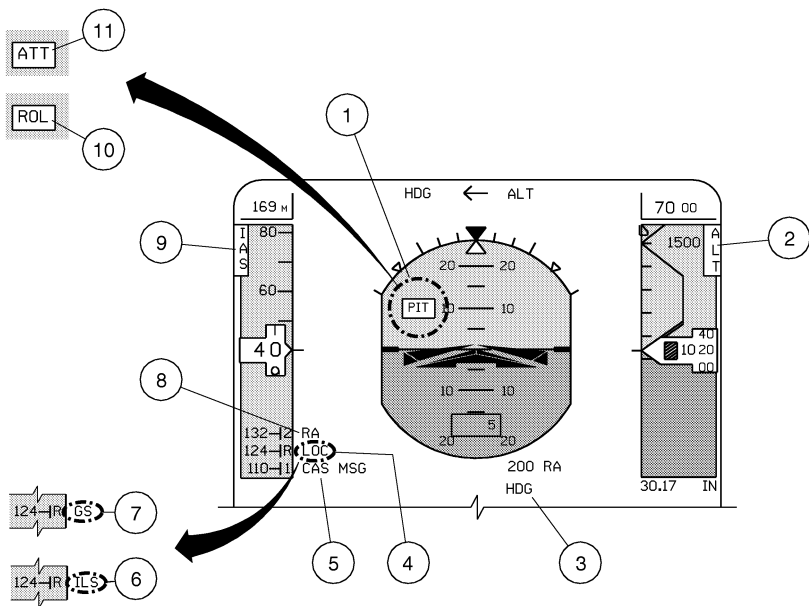

COMPARISON MONITOR ANNUNCIATORS

CAUTION ANNUNCIATORS

The amber caution annunciators are described as follows:

1 - FD FAIL

- If a flight director fails, **FD FAIL** is displayed in the lateral mode annunciator box, and the flight director mode annunciators and command cue are removed.

2 - AP/YD

- Autopilot and yaw damper caution annunciators. **AP/YD** are displayed above the attitude sphere, below the flight director mode annunciators. Refer to PFD Additional Annunciators for more information.

3 - GND PROX

- When the EGPWS indicates a caution conditions **GND PROX** is displayed in the upper right of the ADI sphere. The following aural alerts are considered cautionary:
 - “SINK RATE”;
 - “DON’T SINK”;
 - “TOO LOW TERRAIN”;
 - “TOO LOW FLAPS”;
 - “TOO LOW GEAR”;
 - “GLIDESLOPE”;
 - “CAUTION TERRAIN”;
 - “CAUTION OBSTACLE”.

4 - MSG

- The FMS message annunciator (**MSG**) is displayed to the upper right of the HSI compass. The **MSG** annunciator flashes until the FMS message is cleared from the scratchpad.

5 - TCAS FAIL

- Amber **TCAS FAIL** caution annunciator is displayed to the upper left on the vertical speed display.

6 - DISTANCE DISPLAY FAILURES

- If the DME or FMS distance signal fails, the digital readout is replaced with amber dashes.

7 - COURSE SELECT FAILURE

- If the course select signal fails, the digital readout is replaced with amber dashes and the course pointer is removed from the display. This indication is also given for an invalid heading display or FMS source.

8 - AOA

- Angle of attack information (and calibrated airspeed) are used to calculate stall speed for low speed awareness. If the angle of attack information or indicated airspeed information is invalid, AOA is displayed to the lower right of the airspeed tape.

9 - ATT1 OR ATT2

- If the pilot and copilot are using their normal outside attitude source, there is no attitude source annunciator. If the pilot and copilot have selected the same attitude source, that attitude source (**ATT1** or **ATT2**) is annunciated to the lower left of the attitude sphere on both PFDs.

10 - RA

- If a radio altimeter fails, **RA** is displayed in the digital radio window.

11 - MAX/MIN SPD

- These annunciators are displayed to the left of the attitude sphere. **MIN SPD** is displayed when the vertical speed or airspeed hold mode is engaged and the indicated airspeed drops below 80 kt. **MAX SPD** is displayed anytime indicated airspeed exceeds V_{MO}/M_{MO} .

12 - SG1 OR SG2

- When the symbol generator reversion is selected and one symbol generator is driving both pilot's and copilot's displays, that symbol generator is annunciated (**SG1** or **SG2**) to the upper left of the attitude sphere on both PFDs.

13 - ADC1 OR ADC2

- If the pilot and copilot are using their normal outside air data source, there is no air data annunciator. If the pilot and copilot have selected the same air data source (**ADC1** or **ADC2**) is annunciated to the upper left of the attitude sphere on both PFDs.

14 - WDSHEAR

- When the windshear detection system detects windshear, **WDSHEAR** is displayed to the upper left of the attitude sphere. The annunciator flashes for 10 seconds and then goes on steady. The annunciator is **amber** (caution) if the performance is being increased, and **red** (warning) if the performance is being decreased. If the go-around button is pushed during a windshear caution or warning, the flight director vertical flight director guidance directs the airplane.

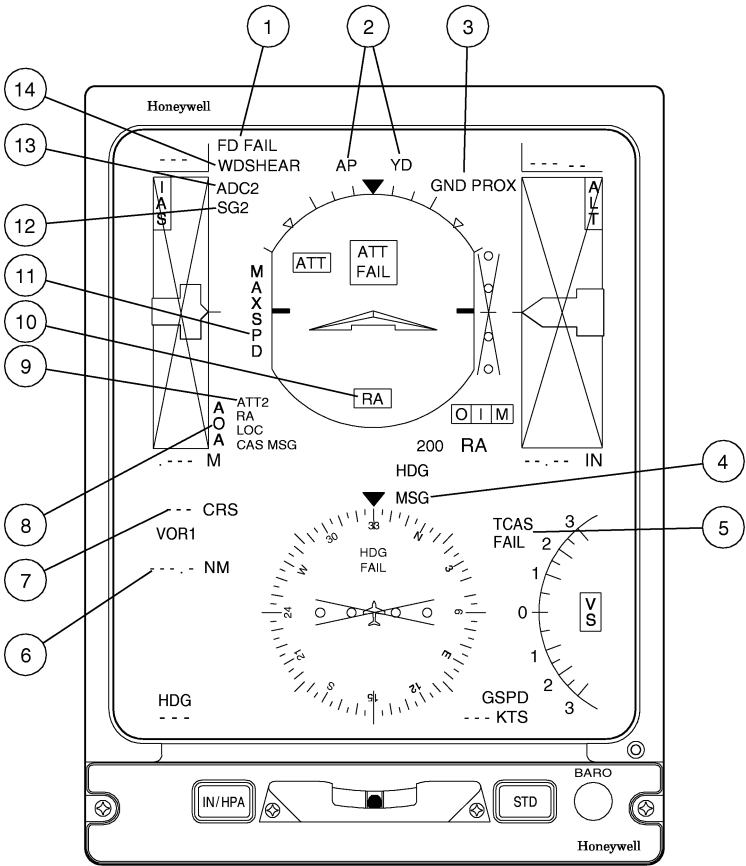

PFD WITH CAUTION ANNUNCIATORS

WARNING ANNUNCIATORS

The red warning annunciators are described as follows:

1 - ATT FAIL

- If either the pitch or roll data fails, the pitch scale marking are removed, the attitude sphere turns cyan, and **ATT FAIL** is displayed in the attitude sphere.

2 - PULL UP

- When the EGPWS indicates a warning condition, **PULL UP** is displayed boxed in the upper right corner of the ADI sphere.

3 - AIR DATA COMPUTER FAILURE

- If the ADC fails, the rolling digit displays of airspeed and altitude are removed, the scale marking are removed and an “X” is drawn through the scales. If the digital Mach display fails, the digital readout is replaced with amber dashes.
- In the case of the vertical speed, the current value pointer is removed, a boxed **VS** is displayed inside the scale.

4 - VERTICAL DEVIATION FAILURE

- If the radio source driving the vertical navigation scale fails, the deviation pointer is removed and a red “X” is drawn through the scale. The scale and pointer are removed for invalid FMS data.

5 - COURSE DEVIATION FAILURE

- If the course deviation data fails, the CDI is removed and a red “X” is drawn through the scale. The course digital readout is replaced with amber dashes.

6 - HDG FAIL

- If the heading select signal fails, the heading bug is removed from the display and **HDG FAIL** is displayed inside the HSI compass. This indication is also given in the event of an invalid heading display.

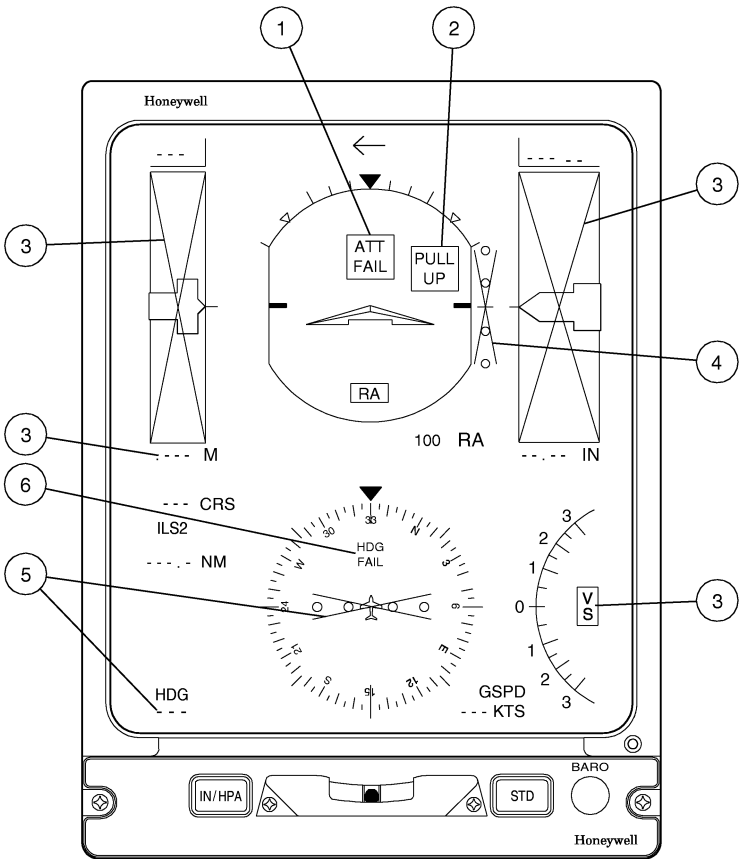

PFD WITH WARNING ANNUNCIATORS

PFD ADDITIONAL ANNUNCIATORS

ATTITUDE DIRECTOR INDICATOR (ADI) DISPLAY AND MODE ANNUNCIATORS

1 - LATERAL FLIGHT DIRECTOR MODE ANNUNCIATORS

- The **HDG**, **VAPP**, **VOR**, **ROL**, **LOC**, **BC** and **LNAV** mode annunciators are displayed. Armed modes are displayed in white, captured modes are displayed in green and boxed in white for 7 seconds after the transition from armed to captured.

2 - VERTICAL FLIGHT DIRECTOR MODE ANNUNCIATORS

- The **VS**, **MACH**, **PIT**, **ASEL**, **TO**, **CLB**, **ALT**, **WSHR**, **SPD**, **DES**, **GS**, **IAS** and **GA** mode annunciators are displayed. Armed modes are displayed in white, while captured modes are displayed in green and boxed in white for 7 seconds after the transition from armed to captured.

3 - VERTICAL DEVIATION DISPLAY

- A **GS** in white is displayed above the vertical deviation scale when the vertical deviation is from an ILS glideslope, and a **FMS** in white is displayed when the vertical deviation is from an FMS.
- If the glideslope data is invalid, the pointer is removed and a red "X" is displayed through the scale. If the FMS data is invalid, the scale, label and pointer are removed.

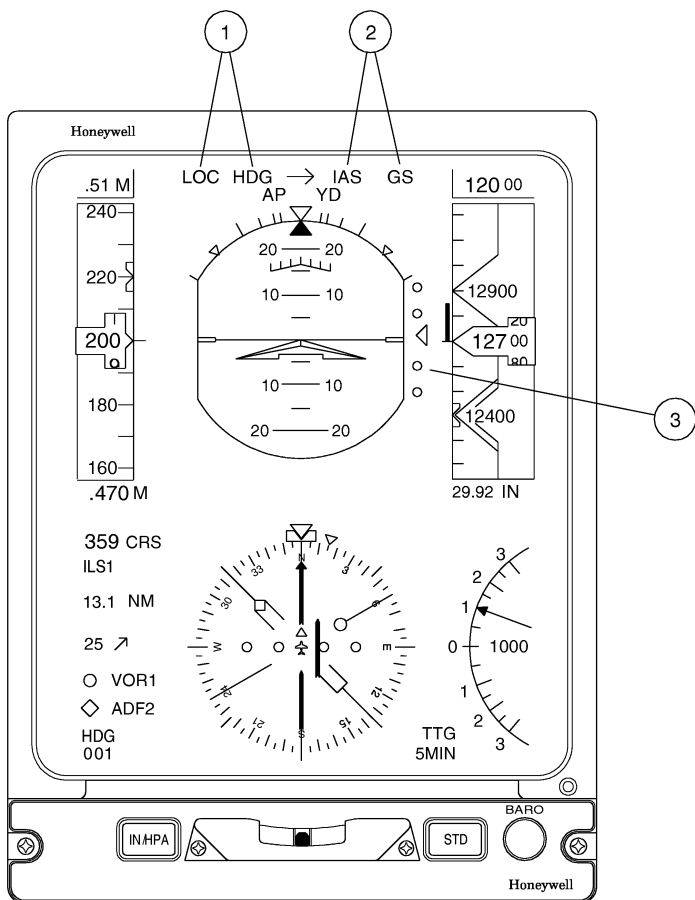

ADI DISPLAY ON THE PFD

1 - AUTOPILOT ANNUNCIATORS

MESSAGE	COLOR	TYPE	STATUS
AP	Green	Steady	Engaged
AP Test	Amber	Steady	Autopilot Test
AP	Amber	Flashes for 5s	Normal AP disconnect
AP	Red	Flashes for 5s then steady	Abnormal AP disconnect
AP	Red	Flashes for 5s	Abnormal AP disconnect in CAT II
TCS	White	Steady while TCS switch is pushed	Touch control steering
TKNB	Amber	Steady	TURN knob is out of detent

2 - YAW DAMPER ANNUNCIATORS

MESSAGE	COLOR	TYPE	STATUS
YD	Green	Steady	Engaged
YD	Amber	Flashes for 5s	Normal yaw damper disconnect
YD	Amber	Flashes for 5s then steady	Abnormal yaw damper disconnect

3 - FMS VERTICAL TRACK ALERT (VTA) ANNUNCIATOR

- For Universal FMS, the annunciator **VTA** is displayed in magenta flashing then steady when the FMS advisory VNAV is selected and the airplane is approaching the top of descent point.

4 - RADIO ALTITUDE MINIMUM ALTITUDE ANNUNCIATOR

- When actual radio altitude decreases to within 100 ft of the set Decision Height value, a white box is displayed. When the actual radio altitude is equal to or less than the set value, **MIN** is displayed in amber (inside the box) and it flashes for 10s.

5 - MARKER BEACON ANNUNCIATOR

- A cyan **O** represents the outer, an amber **M** represents the middle, and a white **I** represents the inner marker. They appear inside a white box, flashing.

6 - RADIO ALTITUDE MINIMUM ALTITUDE ANNUNCIATOR

- An amber **MIN** is displayed (boxed) and flashes for 10 seconds when the actual radio altitude is equal to or less than the set value.

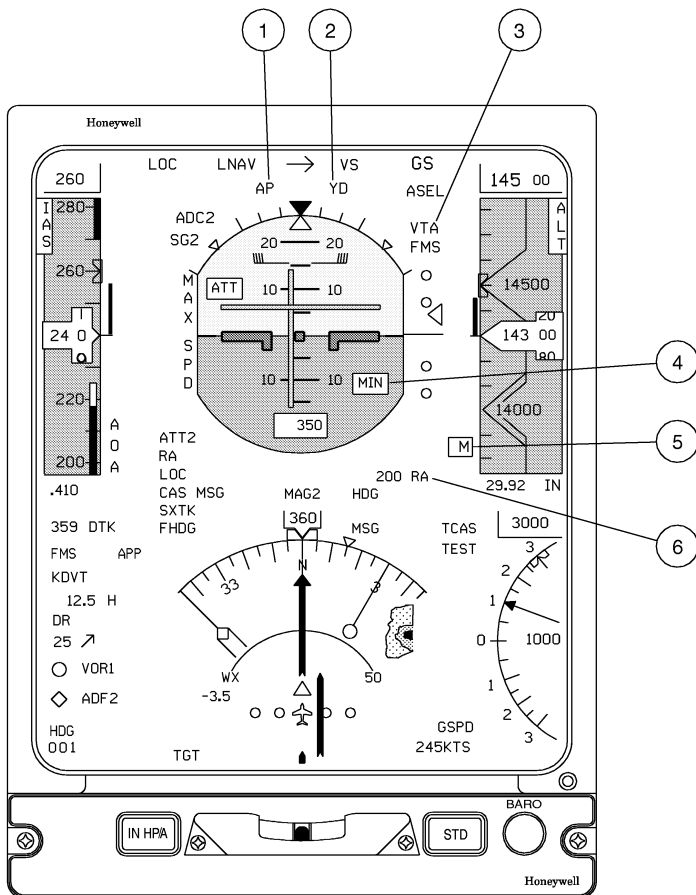

ADI DISPLAY ON THE PFD

1 - CAT II ANNUNCIATOR

- **CAT2** is displayed in green when the conditions for a CAT II approach are satisfied. If these conditions are met, but subsequently lost, **CAT1** in amber flashes for 5 seconds and then goes on steady. If the localizer deviation exceeds the CAT II requirements with radio altitude less than 500 ft the green **CAT2** turns amber and flashes.

HORIZONTAL SITUATION INDICATOR (HSI) DISPLAY

FULL COMPASS DISPLAY

The color of the course pointer, distance display, groundspeed, lateral deviation, and navigation source annunciator are green when the source selected is Short Range Navigation, magenta when FMS is selected as navigation source and yellow when the same navigation source on both sides or secondary NAV source is selected.

2 - MEASUREMENTS

- One of the annunciators **TTG** in white, **ET** in green or **GSPD** in green is displayed.

3 - BEARING POINTER ANNUNCIATORS (COPILOT)

- The **OFF**, **NAV2**, **ADF2**, **FMS** or **VOR2** bearing pointer annunciators may be displayed. If the on-side display controller fails, the default source is VOR2 for the "◇" pointer (copilot's).

4 - BEARING POINTER ANNUNCIATORS (PILOT)

- The **OFF**, **NAV1**, **ADF1**, **FMS** or **VOR1** bearing pointer annunciators may be displayed. If the on-side display controller fails, the default source is VOR1 for the "O" pointer (pilot's).

5 - DISTANCE DISPLAY

- The display is distance to the station for a short-range NAV and the distance to the TO waypoint for the FMS. The display range is from 0 to 409.5 NM for DME and 0 to 4096 NM for FMS. If DME hold is selected when VOR is displayed, an amber **H** is displayed.

6 - NAVIGATION SOURCE ANNUNCIATORS

- One of the Navigation Source Annunciators **VOR1**, **VOR2**, **ILS1**, **ILS2** or **FMS** is displayed.

7 - COURSE POINTER AND DIGITAL DISPLAY

- If short range NAV is selected, the annunciator **CRS** (Course) is displayed. If long range NAV is selected, the annunciator **DTK** (Desired Track) appears .

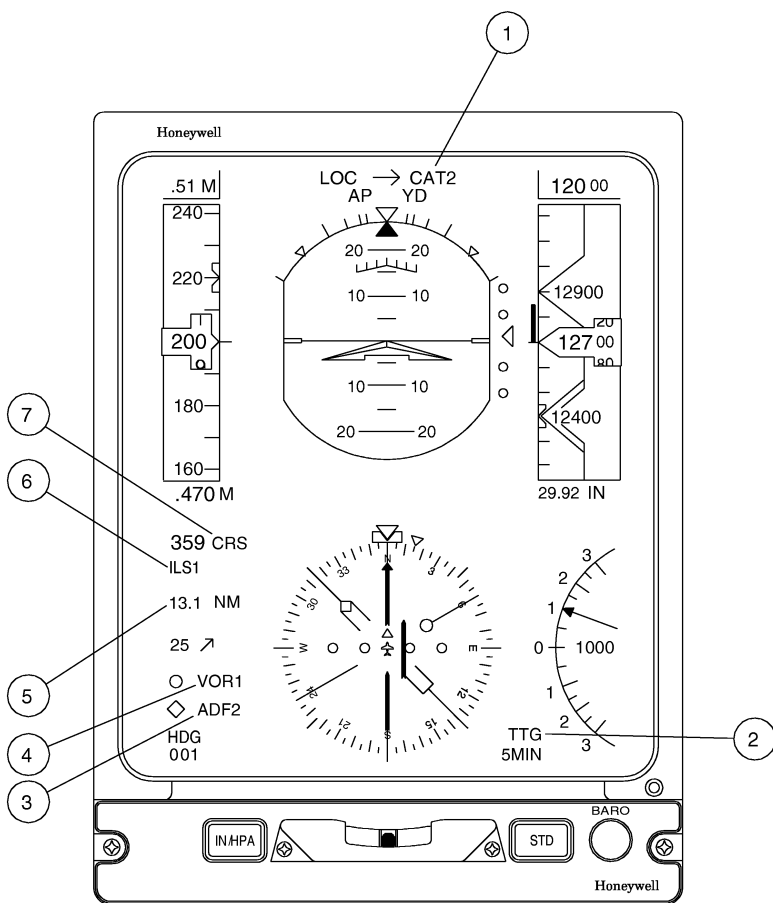

HSI DISPLAY ON THE PFD

COMPASS ARC DISPLAY

1 - HEADING SOURCE ANNUNCIATOR

- When the cross-side heading source is selected, or when the AHRS is in DG mode, the heading source annunciator (**FHDG**) is displayed.
- When the AHRS is in DG mode, the on-side heading source annunciators are **DG1** or **DG2** (in white). When the magnetic heading is invalid, the source annunciator is **HDG1** or **HDG2** (in amber).

2 - FMS MESSAGE AND STATUS ANNUNCIATORS

- The FMS message annunciator (**MSG**, in amber) is displayed in amber and flashes until the FMS condition is cleared.

3 - WEATHER RADAR MODE ANNUNCIATOR

The mode annunciators are described below:

ANNUNCIATOR	COLOR	R/T MODE
FPLN	green	Flight plan mode.
FSBY	green	Forced standby.
GMAP	green	Ground mapping mode.
R/T	green	RCT and turbulence (1).
RCT	green	REACT Mode.
STBY	green	Standby.
TEST	green	Test mode and no faults.
TGT	green	Target alert enabled (2).
TX	green	WX is transmitting but not selected for display, or in STBY or FSTBY (3).
WAIT	green	RTA in warm-up (4).
WX	green	Weather mode (1).
WX/T	green	Weather and turbulence (5).
FAIL	amber	RTA Fail - test mode and faults (6).
GCR	amber	Normal WX with ground clutter reduction.
STAB	amber	Stabilization off.
VAR	amber	Variable gain.

- NOTE:**
- 1) Turbulence detection is only available on the PRIMUS® 880.
 - 2) When target alert is enabled and a level 3 weather return is detected in the forward 15° antenna scan, **TGT** in amber is displayed.
 - 3) **TX** is displayed in amber when the airplane is on ground and **WX** is transmitting, but not selected for display, or in **STBY** and **FSTBY**.
 - 4) Early version of the P1000 annunciates **TX** in amber when the radar is in the warm up mode. In later versions the warm up is indicated by **WAIT** in green.
 - 5) When weather radar is invalid **WX** in amber is displayed.
 - 6) When on the ground and the weather test display is selected, weather failures are indicated by fault cods in the tilt angle field.

4 - WEATHER RADAR TGT/VAR ANNUNCIATORS

- When the target alert mode is armed, the message **TGT** in green appears. It turns amber when a potentially dangerous target is detected. This indicates that the pilot should select a higher range on the weather radar to view the target. When variable radar gain is selected, **VAR** in amber is displayed.

5 - DME HOLD ANNUNCIATOR

- If DME hold is selected when VOR is displayed, **H** in amber is displayed.

6 - FMS HEADING (FHDG) ANNUNCIATOR

- When heading guidance is supplied from the FMS, **FHDG** in magenta is displayed.

7 - FMS STATUS ANNUNCIATOR

The following FMS status annunciators are displayed in amber:

- **INTEG** (Integrity) - The GPS sensor does not meet the required integrity calculations for the current phase of flight.
- **WPT** (Waypoint) - The airplane is approaching a flightplan waypoint.
- **DR** (Dead reckoning) - The FMS is in dead reckoning mode.
- **DGR** (Degrade) - The ability of the FMS to accurately calculate airplane position is degraded.

The following FMS status annunciators are displayed in cyan:

- **SXTK** (Crosstrack) - The airplane is off track.
- **TERM** (Terminal) - The FMS is in the terminal phase of the flightplan.
- **APP** (Approach) - the FMS is in the approach phase of the flightplan. For RNAV (FMS) approaches, the annunciator is displayed steady and for GPS approaches, the annunciator flashes for ten seconds.

The table below shows the Full-scale Deviation for FMS Terminal and Approach Modes:

ANNUNCIATOR (IN CYAN)	MODE	FULL-SCALE LATERAL DEVIATION	FULL-SCALE VERTICAL DEVIATION
APP	GPS Approach	0.3 NM	150 ft
APP (steady)	RNAV Approach	1.25 NM	150 ft
TERM	GPS Terminal	1.0 NM	500 ft

AIRSPEED DISPLAY

When the FGS enters the MAX SPEED mode, the annunciator **MAX SPEED** is displayed in amber to the left of the ADI sphere.

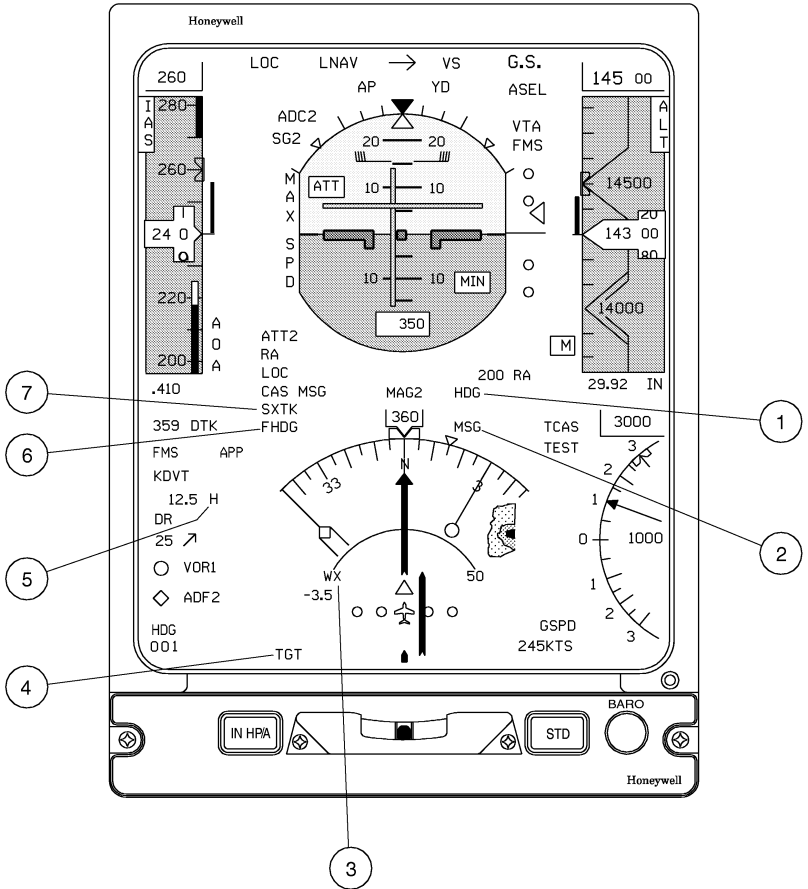

MESSAGES ON THE PFD

VERTICAL SPEED DISPLAY

The picture above shows the location of the annunciator described below:

1 - TCAS STATUS ANNUNCIATOR

Annunciator	Color	TCAS Status
TA ONLY	white	TCAS is in traffic advisory mode only.
TCAS OFF	white	TCAS is off.
TCAS TEST	white	TCAS is in self-test.
TCAS FAIL	amber	TCAS data is invalid.
RA FAIL	red	Resolution advisories are not available.

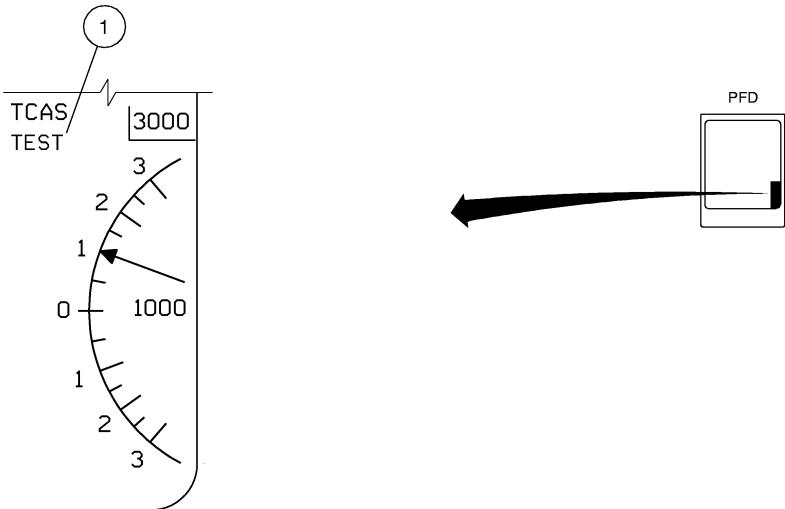

VERTICAL SPEED DISPLAY ON THE PFD

PFD SELF-TEST DISPLAY

To run the EFIS self-test, push and hold the TEST button on the display controller. The PFD displays the following:

- Course select, heading select, radio altitude set, distance, and groundspeed/time-to-go digital displays are replaced with amber (horizontal) dashes.
- Attitude and heading displays are flagged.
- All pointers/scales are flagged.
- All heading bugs/pointers are removed.
- Flight director command cue is removed.
- Radio altimeter digital readout displays radio altimeter self-test value.
- The comparison monitor annunciators are displayed (in amber) **ATT**, **HDG**, and **ILS** (if ILS sources are selected on both sides).
- **TEST** in magenta is annunciated to the upper left of the ADI.
- The annunciator **WDSHEAR** in red is displayed.
- Flight director mode annunciators are removed.
- Radio altitude minimum is displayed at the last set value.

NOTE: The amber annunciator **FD FAIL** is not displayed during the self test.

AURAL WARNINGS

There are two kinds of aural warnings: voice messages and tones.

Voice messages are normally associated with warning messages on EICAS or other warning systems. They are generated whenever a potentially dangerous condition exists, as determined by the GPWS, TCAS and windshear detection system. There are some voice messages that can be cancelled, but others can only be cancelled when the cause that triggered them has been eliminated.

Tones have different forms and indicate some notable airplane events, sometimes in unison with voice messages.

AURAL WARNING UNIT

In order to generate messages and tones, the Aural Warning Unit (AWU) receives signals from the following airplane systems:

- TCAS
- Windshear detection system
- GPWS
- IC-600
- Fire detection system
- Stall protection system
- Trims
- Flaps
- Brakes
- Spoilers
- Radio altimeter
- Autopilot
- Landing gear
- ADC
- Pressurization
- SELCAL

The AWU sends the appropriate audio signal to an audio digital system, which routes the messages to the appropriate speakers.

AWU POWER SOURCE

The AWU is supplied by one DC bus and one Essential DC bus, and is provided with two channels, A and B. Channel B is kept as a backup for channel A, and is automatically activated should channel A fail.

AWU POWER-UP TEST

An AWU power-up test is performed and generates aural warnings for one or both channels operating normally. If both channels have failed, the caution message AURAL WARN FAIL is displayed on EICAS.

AURAL WARNINGS LEVELS

The aural warnings are classified into four levels, presented below in a decreasing level order:

- **Emergency** - Associated with situations that may be hazardous. AWU generates a master warning tone (triple chime) before the warning and voice message may be generated. In any case, the aural warning is repeated every second until deactivated through the master warning button or until the condition that generated the warning has been eliminated.
- **Abnormal** - Associated with malfunctions or failures. AWU generates a master caution tone (single chime) every five seconds, until it is removed, canceled or replaced by a higher priority aural warning. Voice messages are generated after each tone.
- **Advisory** - Associated with minor malfunctions or failures that lead to loss of redundancy or degradation of the affected system's performance.
- **Information** - A remarkable event has occurred.

AURAL WARNINGS ANNUNCIATION PRIORITY

When multiple aural warnings are active, aural warnings among the highest level alert groups shall be sounded first in order and repeated. Once all alerts in the higher group are cancelled or removed, then the second tier group alerts are sounded and repeated.

An alert in process shall be immediately interrupted when an alert of a higher priority needs to be generated.

EXCEPTIONS TO AURAL WARNINGS PRIORITY

When an internal voice message is being annunciated, it shall be completed before another alert, even of a higher priority, is annunciated. This does not apply to internally generated tones which shall be interrupted within 1 second.

If an emergency arises together with a warning that generates continuous sounds, such as a fire or stall, the sound volume is reduced to avoid misunderstanding of the remaining messages, although being loud enough to still warn pilots.

The master warning tone is inhibited when any other emergency alert (internal or external) is occurring at the same time.

LEVEL	ASSOCIATED CONDITION/EICAS MESSAGE	PRIORITY	STONE	VOICE MESSAGE	CANCEL
EMERGENCY	Stall condition.	1	Clacker	None	NO
	Windshear condition (1).	2	None	WINDSHEAR	NO
	Ground proximity condition (1).	3	(1)	(1)	NO
	Traffic proximity condition (1).	4	None (3)	(1)	NO (2)
	Fire in engine or APU. ENG 1 (2) FIRE , APU FIRE.	5	Bell	None	YES
	Airspeed above V _{MO} .	6	Attenson 3	HIGH SPEED	NO
	Landing gear not locked down for landing.	7	Attenson 3	LANDING GEAR	NO
	Cabin altitude above 10000 ft (Normal Mode Operation). or Cabin altitude above 14500 ft (HI ALT Mode Operation - only for airplanes equipped with HI ALT system).	8	Attenson 3	CABIN	YES
	Associated with takeoff configuration warning.	9	Attenson 3	TAKEOFF plus one of the following: -FLAPS -TRIM -SPOILER -BRAKES	NO
	Associated with emergency failures.	10	Attenson 3	None	NO
ABNORMAL	Associated with glide slope deviation.	None	None	GLIDE SLOPE	YES
	Traffic proximity condition.	None	None (3)	TRAFFIC	YES
	Associated with abnormal failures.	None	Master Caution Tone	None	YES

- NOTE:** 1) Messages are generated outside the AWU. For further details, refer to the associated system description.
2) TCAS resolution advisory warning can not be canceled.
3) For airplanes Post-Mod. SB 145-34-0046 and Post-Mod. SB 145-31-0028 or with an equivalent modification factory incorporated.

LEVEL	ASSOCIATED CONDITION/EICAS MESSAGE	PRIORITY	STONE	VOICE MESSAGE	CANCEL
ADVISORY	Autopilot disengagement during approach.	None	None	AUTOPILOT	NO (1)
	Associated with decision height crossing.	None	None	MINIMUM	NO
	Airplane is crossing or has reached a preselected altitude.	None	three 2900 Hz tones	None	NO
INFORMATION	Power up test detected a failure in one channel of AWU.	Not applicable	None	AURAL UNIT ONE CHANNEL	NO
	Associated with incorrect command of pitch trim main or backup channel switches.	None	Single chime	TRIM (2)	NO
	Associated with SELCAL callings.	None	None	SELCAL	NO
	Both AWU channels are operating normally on power up test.	None	None	AURAL UNIT OK	NO
	Takeoff configuration test successful.	None	None	TAKEOFF OK	NO
	Power 1 or 2 fail.	None	None	AURAL UNIT ONE POWER	Not applicable
	When CMU receives a new message.	None	None	INCOMING CALL (3)	NO

(1) For Post-Mod. SB 145-22-0001 airplanes or S/N 145001 through 145003, 145041 and on, the voice message can be cancelled

(2) Applicable to airplanes equipped with HSCU-1009 or -5009 and AWU-5.

(3) For airplanes Post-Mod. SB 145-23-0028.

EICAS MESSAGE

TYPE	MESSAGE	MEANING
CAUTION	AURAL WARN FAIL	Both AWU channels are inoperative.

TAKEOFF CONFIGURATION WARNING

A dedicated aural warning sounds to indicate that airplane configuration is unsuitable for takeoff. Such aural warning is activated whenever the airplane is on the ground, any thrust lever angle is above 60° and at least one of the following conditions is met:

- Flaps are not in takeoff position.
- Parking brakes are applied.
- Pitch trim is out of the green range.
- Any spoiler panel is deployed.

More than one aural warning may be generated, if more than one condition are met.

TEST BUTTON

A test button is provided to allow checking the takeoff configuration warning integrity, by simulating power levers advanced. A voice message is generated after successful tests. Unsuccessful tests will generate an EICAS message and a voice message associated with the out-of-configuration item.

EICAS MESSAGE

TYPE	MESSAGE	MEANING
WARNING	NO TAKEOFF CONFIG	Airplane is not in takeoff configuration.

CONTROLS AND INDICATORS

1 - TAKEOFF CONFIGURATION CHECK BUTTON

- Allows checking the takeoff configuration warning.

CONTROL
PEDESTAL

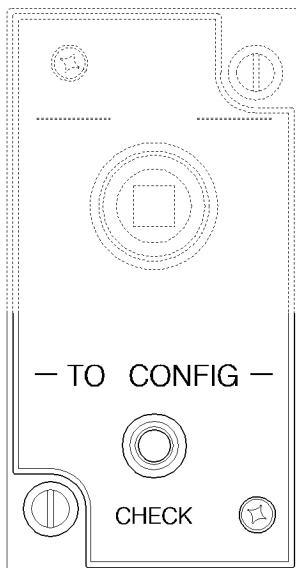
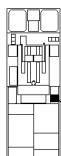

TAKEOFF CONFIGURATION CHECK BUTTON

STALL PROTECTION SYSTEM

GENERAL

To help detect imminent stalls and to avoid stalling the airplane, the EMB-145 is provided with a Stall Protection System (SPS). The SPS is composed of one computer box with two independent channels, the SPS panel, two Angle of Attack (AOA) sensors, two stick shaker actuators, and one stick pusher actuator. The system provides sensitive, visual and aural indications of an impending stall. To avoid spurious actuation, the SPS receives signals from many airplane systems, thus correcting its set point according to flaps and landing gear position, icing and windshear conditions and Mach number.

INTERFACES

Each channel receives data from the following on-side airplane systems: AHRS or IRS, ADC, flaps, landing gear, air/ground, windshear detection, ice detection and radio altimeter. Each Stall Protection Computer (SPC) channel receives information from its associated AOA sensor and sends it to the opposite channel in order to compensate side slip influence on angle of attack measurements. A locked AOA sensor signal is not considered in stall calculations and in this case the channel will be deactivated. If a stall condition is imminent, the system first actuates the stick shaker and disengages the autopilot. If no corrective action is taken and the airplane is on the verge of entering a stall, the stick pusher is actuated, which pitches the nose down. Simultaneously, a clacker is generated in the aural warning system. A bug in the airspeed scale on the PFD indicates the stall speed for the associated condition and a pitch limit indicator is presented on EADI to indicate the current margin to the stick shaker angle. When the airplane reaches 0.5 g, the stick pusher is inhibited, stopping its actuation over the control column. A quick disconnect button is provided in the control wheel to permit pilots to cut the system if the need arises. To disconnect the system in case of failure, the SPS panel provides one cutout button for each channel. An EICAS message is presented to indicate that the system has failed or is cutout.

EICAS displays the SPS/ICE SPEEDS message to indicate that the Ice Detection/SPS interface logic (Ice Compensation) is active, and consequently the SPS will actuate at reduced angle of attack values for flaps 9°, 18° and 22°.

NOTE: The first in-flight ice detection, by any ice detector, activates the ice compensation.

- The ice compensation is inhibited during 5 minutes after takeoff.
- The ice compensation is reset only on the ground, by pressing the SPS Test Button.

SYSTEM INHIBITION

The stick pusher does not actuate in the following conditions:

- On the ground (except during test).
- Below 0.5 g.
- If the quick disconnect button is pressed (except for JAA certification).
- Below 200 ft AGL. If radio altimeter has failed, this condition reverts to a 10-second delay after takeoff.
- If any cutout buttons are released.
- Above 200 KIAS.
- If at least one channel is inoperative.

SYSTEM TEST

A test button is provided to test the system on the ground. The system operates normally if not tested. Test button remains illuminated if the system has not been tested or after unsuccessful tests. It is not possible to test the system in flight. This inhibition is valid for 30 seconds after landing, above 70 KIAS or with landing gear not downlocked.

NOTE: Test button remains illuminated if quick disconnect button is pressed during test.

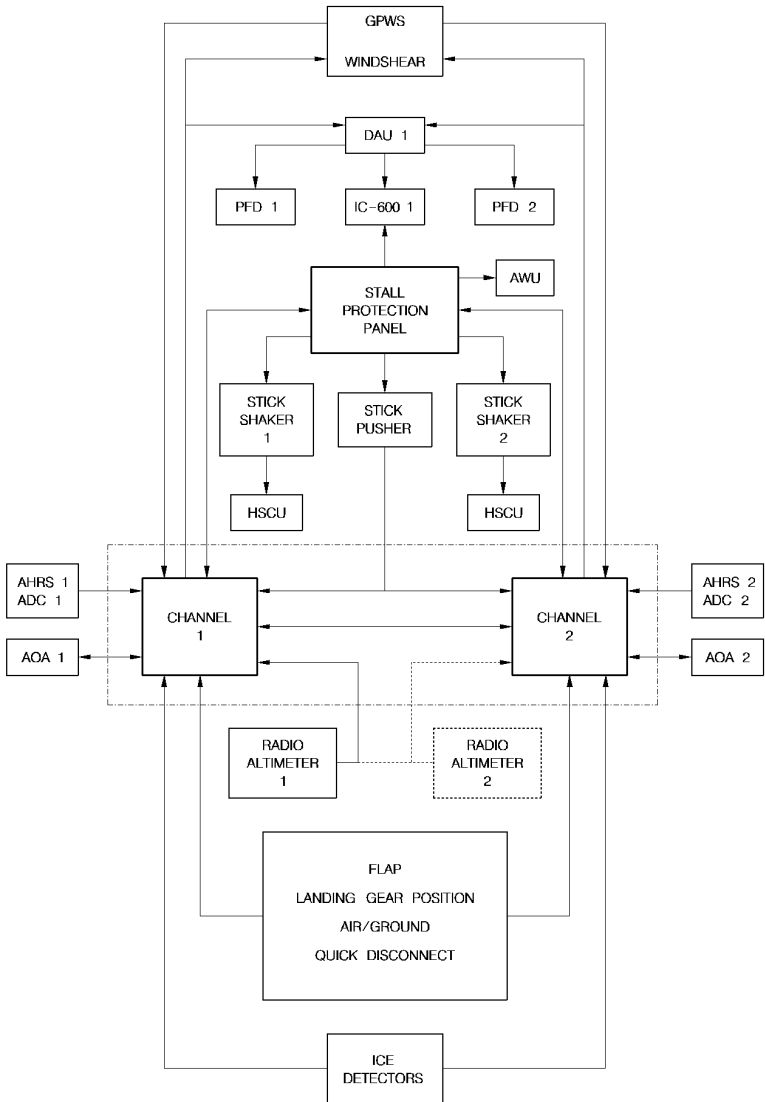

STALL PROTECTION SYSTEM SCHEMATIC

EICAS MESSAGES

TYPE	MESSAGE	MEANING
WARNING	SPS 1(2) INOP	Associated SPS computer channel has failed or AOA vane failed.
	SPS 1-2 INOP	Both SPS computer channels have failed or both AOA vanes have failed or stick pusher has failed or is cutout.
CAUTION	SPS ADVANCED	Stick shaker and pusher actuation is set to higher speeds due to: <ul style="list-style-type: none"> – Flap signal disagreement. – Failure in at least one SPS channel. – AHRS or ADC parameters disagree. – Air/Ground signs disagree. – Landing gear down and locked indications disagree.
	STICK PUSHER FAIL	Stick pusher actuator has been commanded but has not moved.
ADVISORY	SPS/ICE SPEEDS	SPS actuation angle is advanced for flaps 9°, 18° and 22°.

NOTE: Advisory SPS/ICE SPEEDS messages are inhibited for the first 5 minutes after takeoff.

CONTROLS AND INDICATORS

STALL PROTECTION SYSTEM PANEL

1 - CUTOUT BUTTON (guarded)

- Cuts out the associated channel.
- A striped bar illuminates inside the button to indicate that it is in the cutout position.

2 - TEST BUTTON

- Starts the test sequence, as follows:
 - Button illuminates.
 - Both stick shakers actuate.
 - Pusher actuates.
 - Button illumination extinguishes.

NOTE: - Test sequence is completed within a maximum of 5 seconds.

- The TEST button must be released at the first sign of stick shaker actuation.

- Button is kept illuminated after an unsuccessful test or if the system has not been tested.

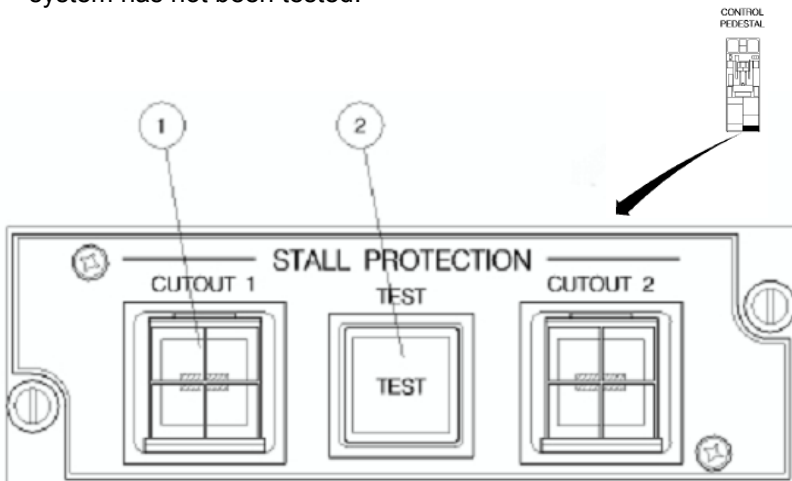

STALL PROTECTION SYSTEM PANEL

PFD INDICATIONS

1 - PITCH LIMIT INDICATOR

- Displayed on the EADI parallel to the airplane symbol.
- Indicates the remaining margin left for the stick shaker angle of attack set point.
- Indication is presented whenever the margin reaches 10°.
- Color:
 - green for margin from 10° up to 5°.
 - amber for margin between 5° and 2°.
 - red for margin below 2°.

2 - LOW AIRSPEED AWARENESS

- Displayed in the airspeed scale when airspeed is near stall speed for the current configuration.

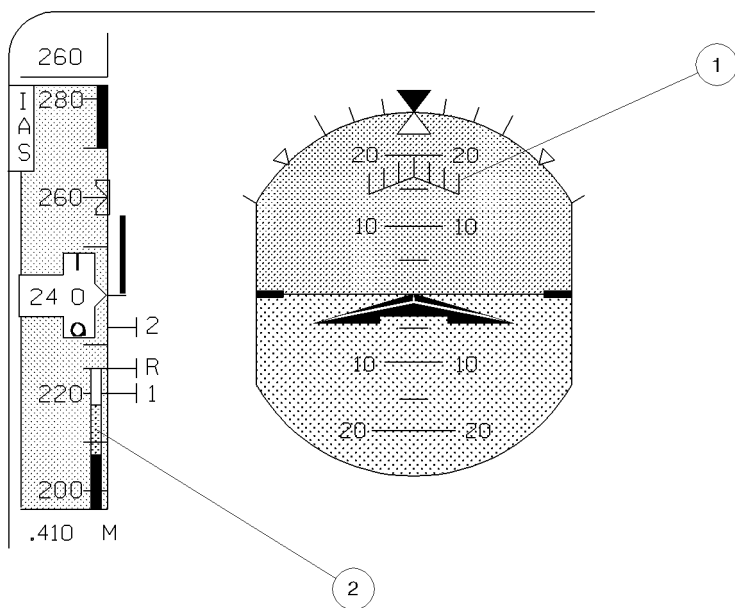
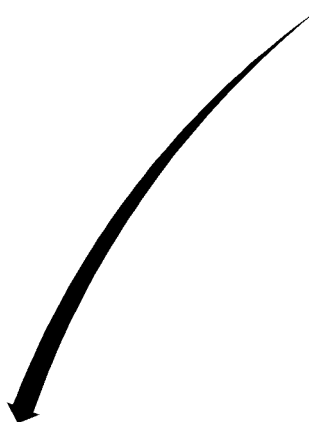
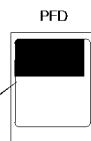

PRIMARY FLIGHT DISPLAY

GROUND PROXIMITY WARNING SYSTEM

The purpose of the Ground Proximity Warning System (GPWS) is to avoid accidents caused by Controlled Flight Into Terrain (CFIT) and also severe windshear.

The GPWS is based on radio altitude (“look down”) information. Some airplanes may be optionally equipped with the Enhanced Ground Proximity Warning System (EGPWS). The EGPWS incorporates GPWS functions with additional features like Terrain Clearance Floor, Terrain Look Ahead Alerting and Terrain Awareness Display. These functions use airplane geographic position, airplane altitude and an internal terrain database to predict potential conflicts between the airplane's flight path and terrain, and to provide graphic displays of the conflicting terrain.

- NOTE:**
- Unless otherwise indicated, the system description below is applicable to the GPWS and to the EGPWS.
 - Airplanes equipped with EGPWS version 216 incorporates additional features like Peaks Mode, Runway Field Clearance Floor, Obstacle Alerting and Geometric Altitude.

The GPWS/EGPWS is a useful navigation aids when flying at low altitude, generally within 2500 ft above terrain. It provides voice messages, EICAS message and PFD indication (EGPWS only) to alert the flight crew, so that they may take appropriate action.

The GPWS/EGPWS interfaces with the followings systems and equipment:

- Radio Altimeter - The radio altimeter provides altitude above ground, how fast the altitude decreases as a result of airplane sinkage or ground profile change and the validity signal.
- IC-600s - The IC-600s provide glideslope deviation, localizer deviation, selected decision height, selected course, packed discrete and selected terrain range.
- ADCs - The ADCs provide uncorrected barometric altitude, corrected barometric altitude, computed airspeed, true airspeed, barometric altitude rate and static air temperature.
- AHRs/IRS - The AHRs/IRS provide magnetic heading, pitch and roll angle, longitudinal and normal acceleration.
- FMS - The FMS provides latitude, longitude, ground speed, true tracking, true heading and NAV mode. The same is applicable when the airplane is equipped with dual FMS.

- GPS - The GPS provides latitude, longitude and altitude.
- Landing gear - The landing gear provides a discrete signal that indicates gear down/locked condition.
- Flap - The Flap Control Unit provides one discrete signal that indicates whether or not flaps are in landing position.
- AWU - The AWU receives the aural messages to be enunciated. It also provides a discrete signal to indicate that the glideslope advisory alert may be canceled without any restriction.
- Terrain Inhibit Switch - It is used in approach mode, in airports not covered by an EGPWS database, assuring protection against unwanted terrain alerts.

Some modes may have their associated envelopes shifted, so as to suit particular airport requirements or to avoid nuisance warnings under some flight situations. This feature is achieved either with calculations or data provided by the FMS, if installed.

The GPWS/EGPWS provides alerts associated with the following flight conditions:

- Mode 1 - Excessive descent rate.
- Mode 2 - Excessive closure rate to terrain.
- Mode 3 - Altitude loss after takeoff.
- Mode 4 - Insufficient terrain clearance.
- Mode 5 - Excessive deviation below glideslope beam.
- Mode 6 - Callouts.
- Mode 7 - Windshear.
- Terrain Awareness Alerting and Warning (EGPWS mode only).
- Terrain Clearance Floor (EGPWS mode only).

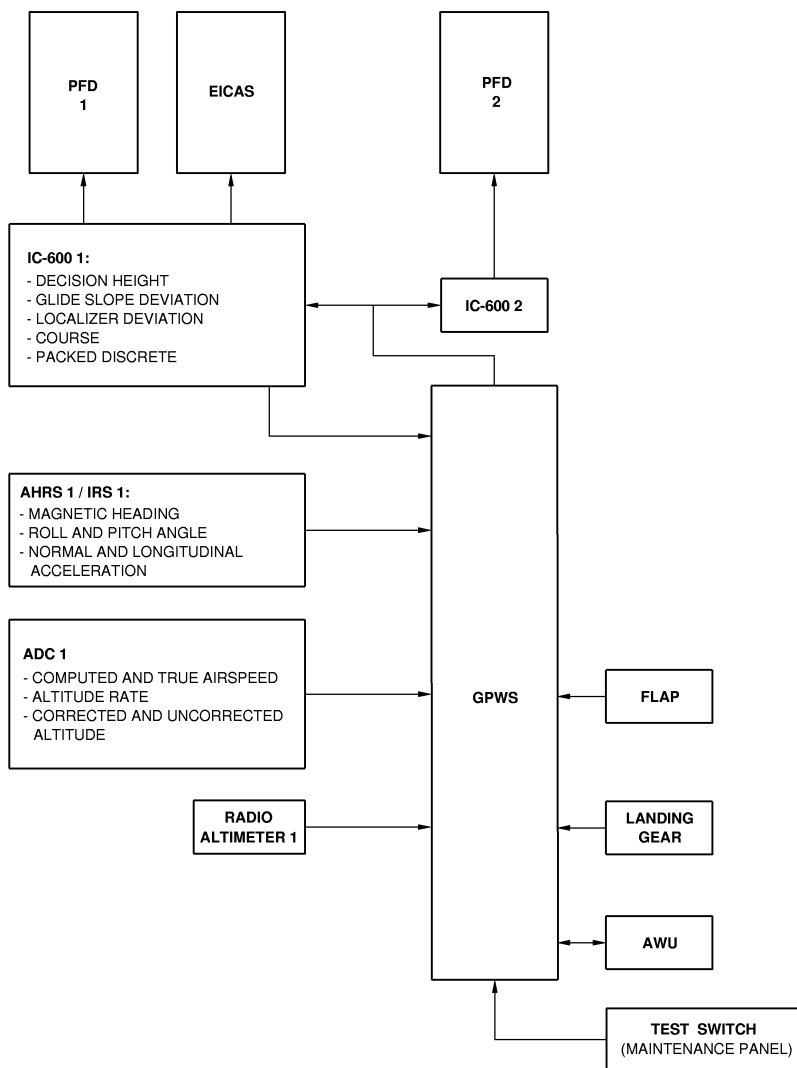

GPWS SCHEMATIC

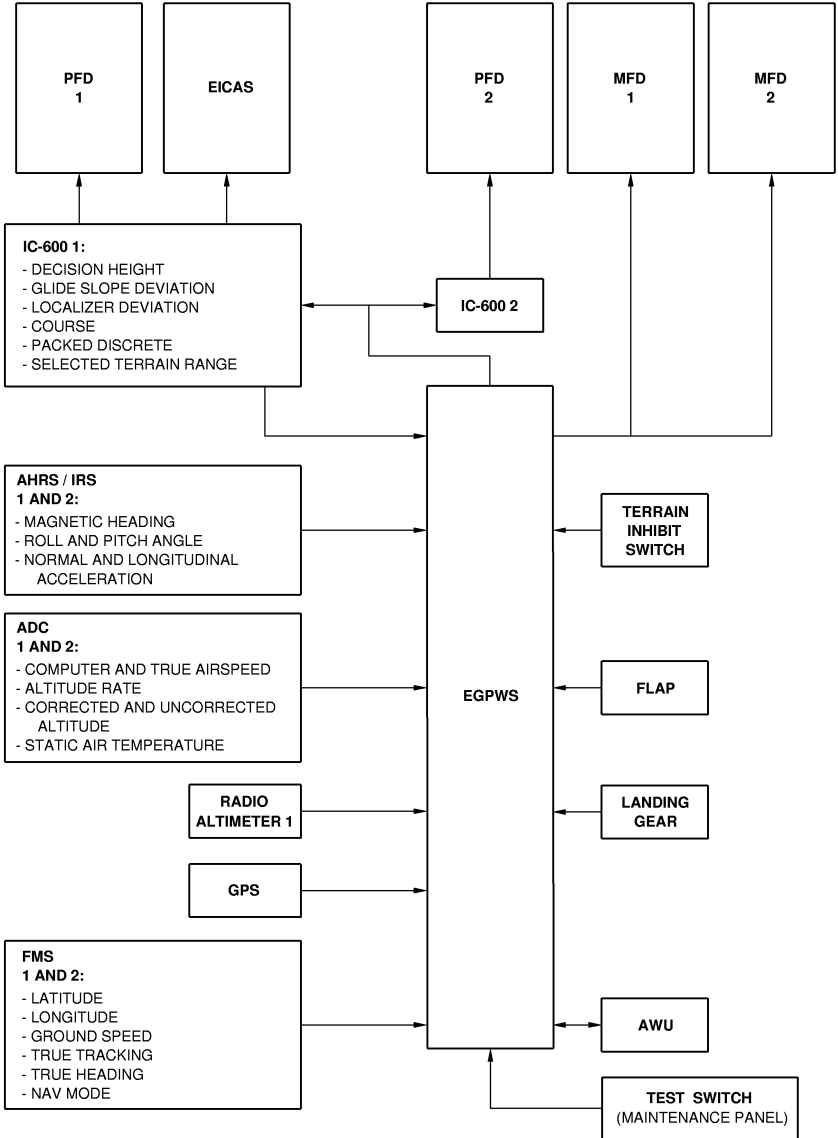

EGPWS SCHEMATIC

MODES AND MESSAGES

MODE 1 - EXCESSIVE DESCENT RATE

Mode 1 provides alerts and warnings when the airplane has attained an excessive descent rate in respect to altitude above ground level (AGL) during the descent and approach phases of flight.

This mode has outer (sink rate) and inner (pull up) alert/warning boundaries:

Minimum Terrain Clearance (MTC) for "SINK RATE" message triggering:

- Minimum: 30 ft at 1000 ft/min of descent Altitude Rate.
- Maximum: 2450 ft at 5007 ft/min or greater of descent Altitude Rate.

Minimum Terrain Clearance (MTC) for "WHOOB WHOOP PULL UP" or "PULL UP" message triggering:

- Minimum: 30 ft at 1710 ft/min of descent Altitude Rate.
- Maximum: 2450 ft at 7125 ft/min or greater of descent Altitude Rate.

Penetration of the outer (sinkrate) boundary will result in:

- Aural message "**SINK RATE**". The message will be repeated as long as the penetration increases; and
- "**GPWS**" warning message on EICAS for airplane equipped with GPWS; or
- Amber "**GND PROX**" indication on the PFD for airplane equipped with EGPWS.

Penetration of the inner (pull up) boundary causes the repeated aural message until the condition is cleared, as follows:

- Aural message "**WHOOB WHOOP PULL UP**" and "**GPWS**" warning message on EICAS for airplanes equipped with GPWS; or
- Aural message "**PULL UP**" and red "**PULL UP**" indication on the PFD for airplanes equipped with EGPWS.

If a valid ILS Glideslope front course signal is received and the airplane is above the glideslope centerline, the sinkrate boundary is adjusted to prevent unwanted alerts when the airplane is safely capturing the glideslope.

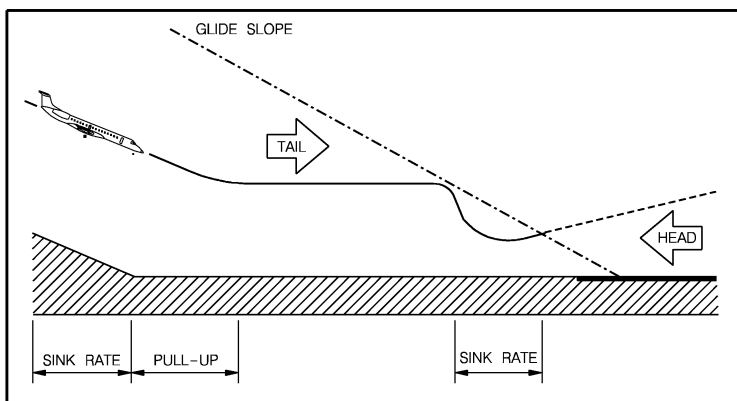
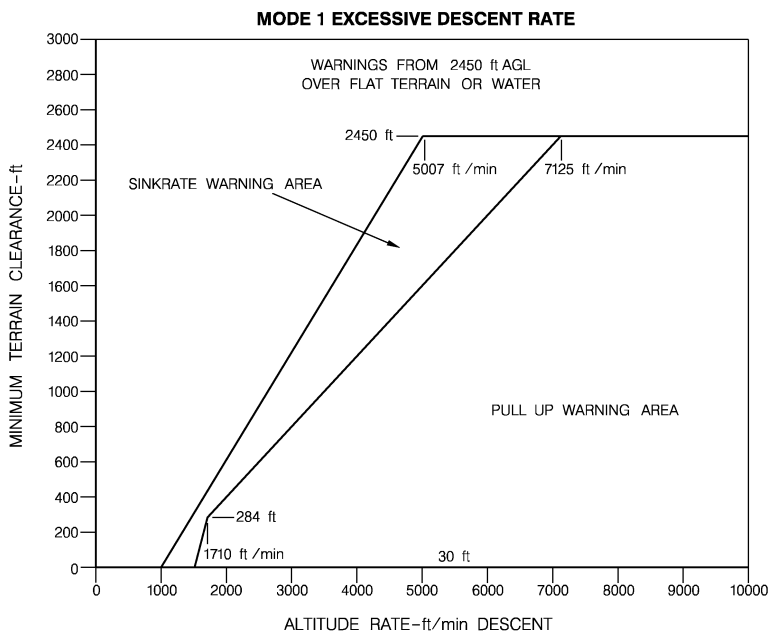

GPWS/EGPWS MODE 1 SCHEMATIC

MODE 2 - EXCESSIVE CLOSURE RATE TO TERRAIN

Mode 2 provides alerts and warnings based on airspeed, airplane gear/flap configuration, radio altitude, and excessive closure rate to terrain. Mode 2 exists in two forms: 2A and 2B.

MODE 2A

Mode 2A is selected when the flaps are not in landing configuration and the airplane is not on the glide slope beam.

Minimum Terrain Clearance (MTC) for "**TERRAIN TERRAIN**" message triggering:

- Minimum: 30 ft at 2038 ft/min of Closure Rate.
- Maximum:
 - 1650 ft at 5733 ft/min or greater of Closure Rate, for an airspeed equal or below 220 KIAS.
 - 2450 ft at 9800 ft/min or greater of Closure Rate for an airspeed equal or above 310 KIAS.

If the airplane penetrates the Mode 2A envelope, the situation results in:

- Aural message "**TERRAIN, TERRAIN**"; and
- "**GPWS**" warning message on EICAS for airplanes equipped with GPWS; or
- Amber "**GND PROX**" indication on the PFD for airplanes equipped with EGPWS.

If the airplane continues to penetrate the envelope, the aural message switches to messages described below, until the condition is cleared:

- Aural message "**WHOO WHOO PULL UP**" and "**GPWS**" warning message on EICAS for airplanes equipped with GPWS; or
- Aural message "**PULL UP**" and red "**PULL UP**" indication on the PFD for airplanes equipped with EGPWS.

The visual and aural messages will remain on until the airplane has gained 300 ft of barometric altitude.

MODE 2A TERRAIN CLOSURE RATE

STATIC ALERT/WARNING ENVELOPE

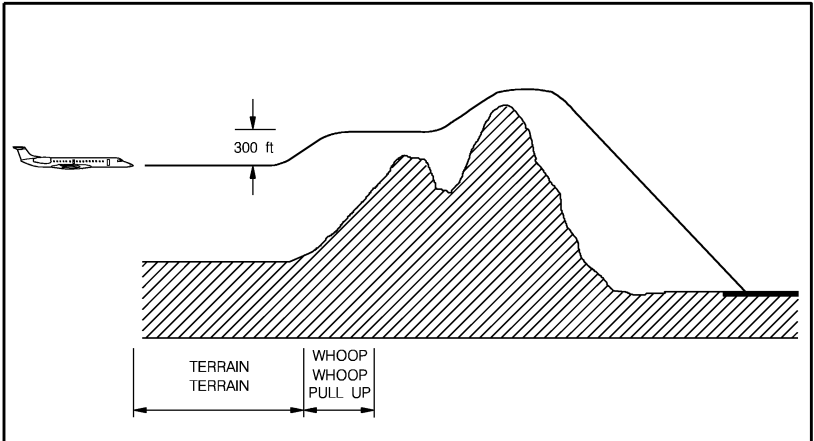
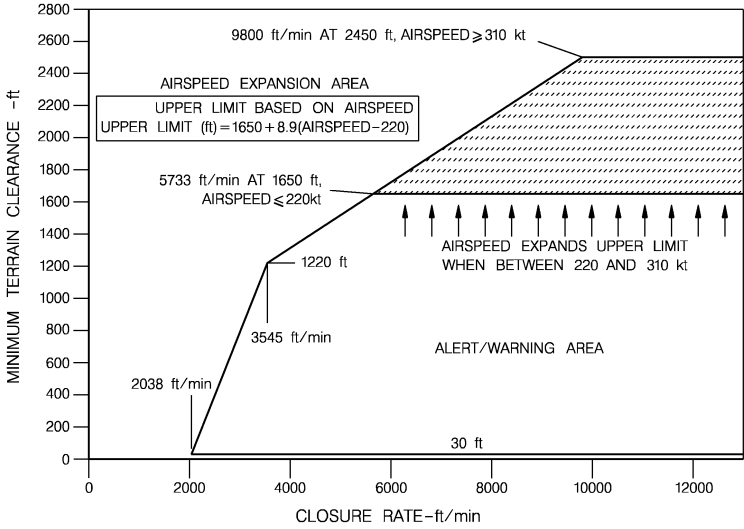

GPWS/EGPWS MODE 2A SCHEMATIC

MODE 2B

Mode 2B is selected when the flaps are in landing configuration or when making an ILS approach with glide slope and localizer deviations below 2 dots.

Minimum Terrain Clearance (MTC) for "**TERRAIN TERRAIN**" message triggering:

- Minimum: 30 ft at 2038 ft/min of closure rate.
- Maximum:
 - 789 ft at 3000 ft/min or greater of closure rate. This steady value can also vary from 200 ft up to 600 ft for flaps set to landing configuration.

If the airplane penetrates the Mode 2B envelope with both gear and flaps in the landing configuration, the message "**TERRAIN**" is sounded.

If the airplane penetrates the mode 2B envelope with either the landing gear UP or flaps not in landing configuration will result in:

- Aural message "**TERRAIN, TERRAIN**"; and
- "**GPWS**" warning message on EICAS for airplanes equipped with GPWS; or
- Amber "**GND PROX**" indication on the PFD for airplanes equipped with EGPWS.

If the airplane continues to penetrate the envelope, the aural message switches to messages described below, until the condition is cleared:

- Aural message "**WHOO WHOO PULL UP**" and "**GPWS**" warning message on EICAS for airplanes equipped with GPWS; or
- Aural message "**PULL UP**" and red "**PULL UP**" indication on the PFD for airplanes equipped with EGPWS.

MODE 2B TERRAIN CLOSURE RATE

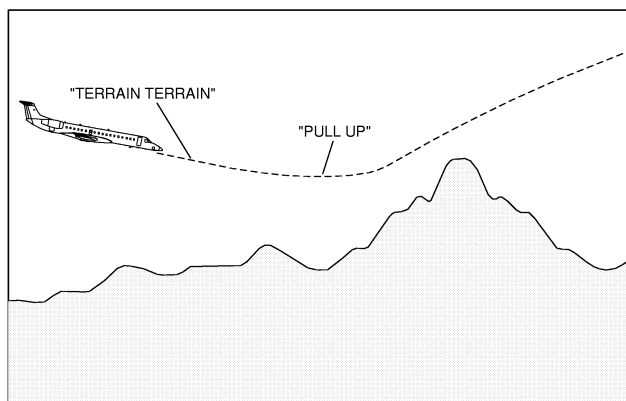
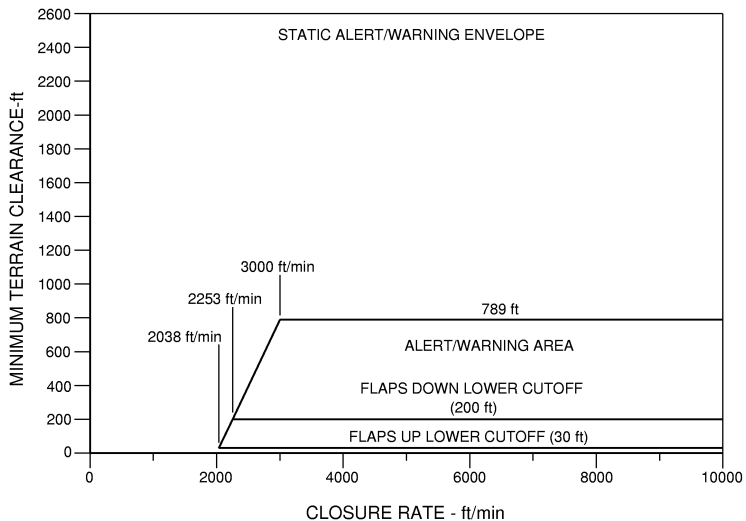

GPWS/EGPWS MODE 2B SCHEMATIC

MODE 3 - ALTITUDE LOSS AFTER TAKEOFF

Mode 3 provides alerts and warnings for a significant altitude loss after takeoff with landing gear UP or flaps in other than landing configuration. The amount of altitude loss required to trigger the warning depends on the height of the airplane above the terrain.

Minimum Terrain Clearance (MTC) for “**DON'T SINK, DON'T SINK**” message triggering:

- Minimum: 30 ft at 5 ft of altitude loss.
- Maximum: 1500 ft at 143 ft or greater of altitude loss.

Significant altitude loss after takeoff or during a low altitude go-around activates the aural message “**DON'T SINK, DON'T SINK**” and:

- “**GPWS**” warning message on EICAS for airplanes equipped with GPWS; or
- Amber “**GND PROX**” indication on the PFD for airplanes equipped with EGPWS.

The audio message is only annunciated twice, unless excessive altitude loss continues to accumulate.

Once triggered, the visual message can only be cancelled achieving a positive rate of climb relative to the original altitude. Therefore, as long as the original altitude is not crossed, any descent will trigger the aural and visual messages again. After crossing the original altitude, a new altitude value is set every moment.

MODE 3 ALTITUDE LOSS AFTER TAKEOFF

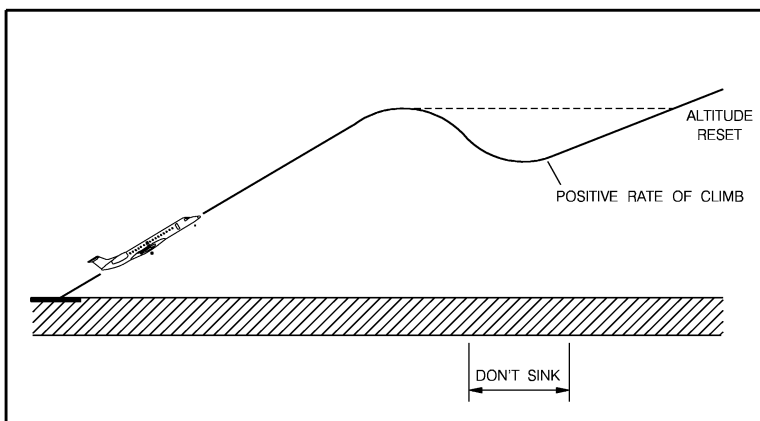
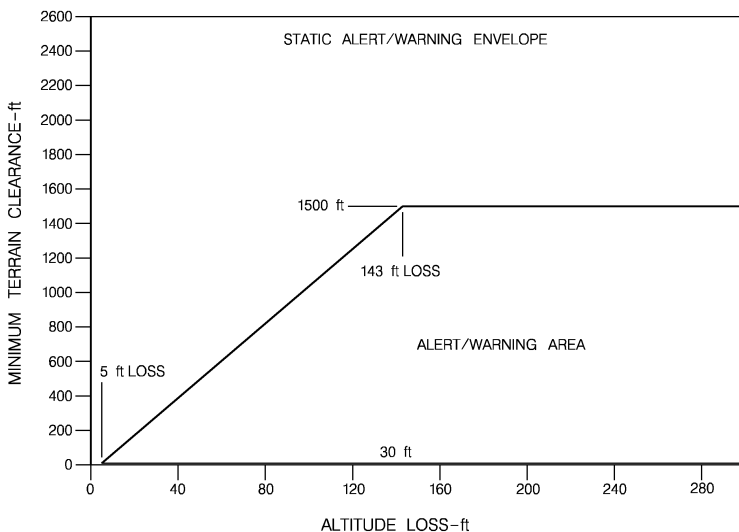

GPWS/EGPWS MODE 3 SCHEMATIC

MODE 4 - INSUFFICIENT TERRAIN CLEARANCE

Mode 4 provides alerts for insufficient terrain clearance with respect to phase of flight and speed. Mode 4 exists in three forms, 4A, 4B and 4C.

MODE 4A

Mode 4A is active during cruise and approach with the landing gear UP.

Minimum Terrain Clearance (MTC) for **"TOO LOW GEAR"** message triggering:

- Minimum: 30 ft.
- Maximum: 500 ft for an airspeed equal or less than 190 KIAS.

Minimum Terrain Clearance (MTC) for **"TOO LOW TERRAIN"** message triggering:

- Minimum: 30 ft.
- Maximum: 1000 ft for an airspeed equal or higher than 250 KIAS.

If during cruise the ground is slowly getting closer and the airplane is not in the landing configuration or during approach with an unintentional gear up landing, the aural message **"TOO LOW TERRAIN"** will be sounded. Once the message has been issued, an additional 20% altitude loss is required for the issuing of a new message.

The **"GPWS"** warning message is displayed on EICAS for airplanes equipped with GPWS and the amber **"GND PROX"** indication on the PFD for airplanes equipped with EGPWS.

If the airplane penetrates below the 500 ft AGL boundary with the landing gear still up, the aural message will be **"TOO LOW GEAR"**. Once a message is issued, an additional 20% altitude loss is required for the issuing of a new message.

The visual and aural messages cease when the mode 4A is exited.

MODE 4A MINIMUM TERRAIN CLEARANCE

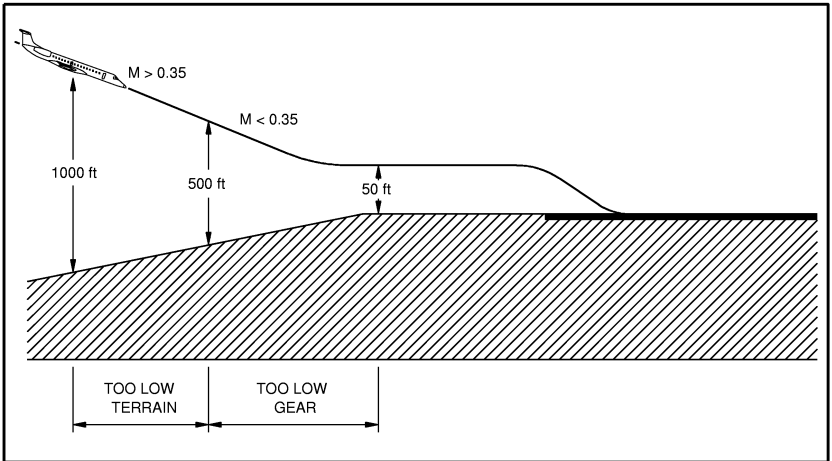
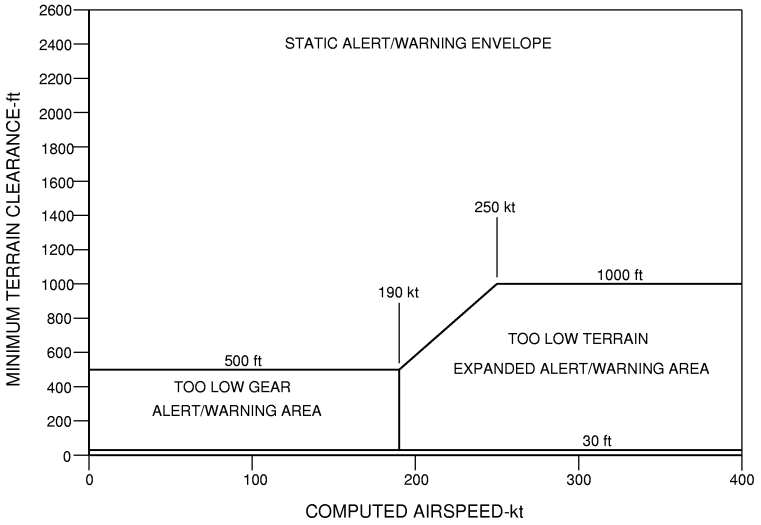

GPWS/EGPWS MODE 4A SCHEMATIC

MODE 4B

Mode 4B is active during cruise and approach with the landing gear down and flaps in other than landing configuration.

Minimum Terrain Clearance (MTC) for "**TOO LOW FLAPS**" message triggering:

- Minimum: 30 ft.
- Maximum: 245 ft for an airspeed equal or less than 159 KIAS.

Minimum Terrain Clearance (MTC) for "**TOO LOW TERRAIN**" message triggering:

- Minimum: 30 ft.
- Maximum: 1000 ft for an airspeed equal or higher than 250 KIAS.

If during cruise the ground is slowly getting closer and the airplane is not in the landing configuration, or during approach with an unintentional gear up landing, the aural message "**TOO LOW TERRAIN**" will be sounded. Once the message is issued, an additional 20% altitude loss is required for the issuing of a new message.

The "**GPWS**" warning message is displayed on EICAS for airplanes equipped with GPWS and the amber "**GND PROX**" indication on the PFD for airplanes equipped with EGPWS.

If the airplane penetrates below the 245 ft AGL boundary with the landing gear down and flaps in other than landing configuration, the aural message will be "**TOO LOW FLAPS**". Once message is issued, an additional 20% altitude loss is required for the issuing of a new message.

The visual and aural messages cease when the mode 4B is exited.

MODE 4B MINIMUM TERRAIN CLEARANCE

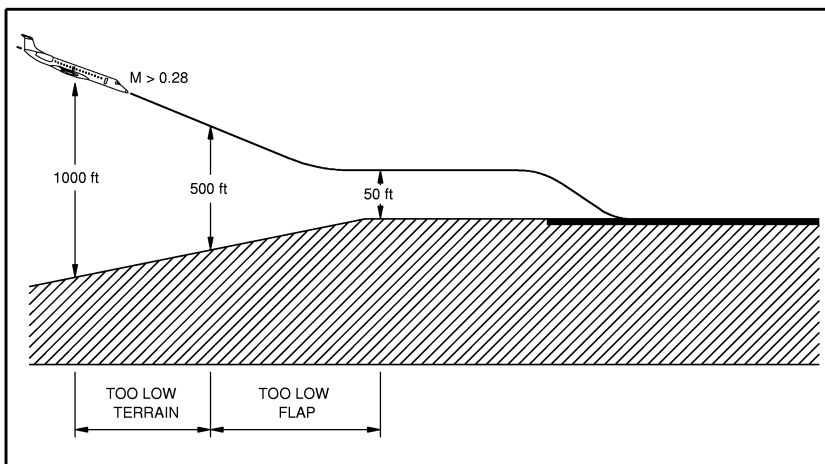
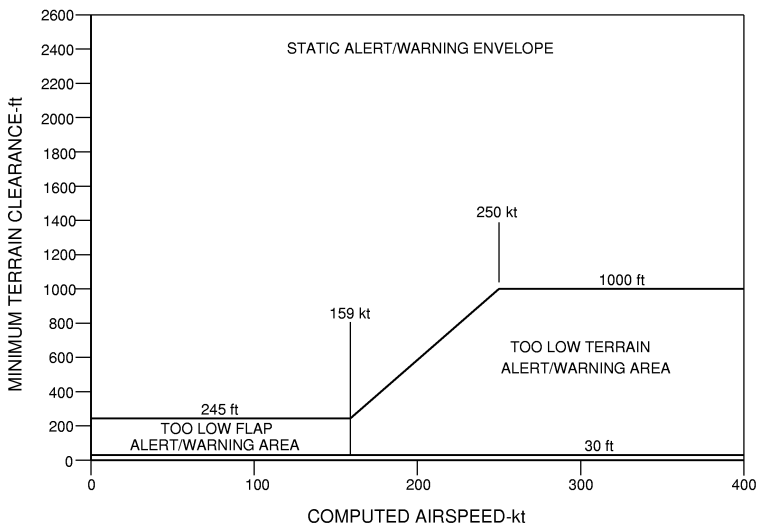

GPWS/EGPWS MODE 4B SCHEMATIC

MODE 4C

Mode 4C is active during takeoff phase or low altitude go-around with either the landing gear or flaps in other than landing configuration, when the terrain is rising closer than the airplane is climbing.

Only in this case, the Minimum Terrain Clearance is a function of the Radio Altitude of the airplane.

Minimum Terrain Clearance (MTC) for **"TOO LOW TERRAIN"** message triggering:

- Minimum: 30 ft.
- Maximum:
 - 500 ft at 667 ft or greater of radio altitude for an airspeed less or equal or less than 190 KIAS.
 - 1000 ft at 1333 ft or greater of radio altitude for an airspeed equal or above 250 KIAS.

If during takeoff or low altitude go-around with either the landing gear or flaps in other than landing configuration, when the terrain is rising more steeply than the airplane is climbing, the aural message **"TOO LOW TERRAIN"** will be sounded.

The **"GPWS"** warning message is displayed on EICAS for airplanes equipped with GPWS and the amber **"GND PROX"** indication on the PFD for airplanes equipped with EGPWS.

MODE 4C MINIMUM TERRAIN CLEARANCE

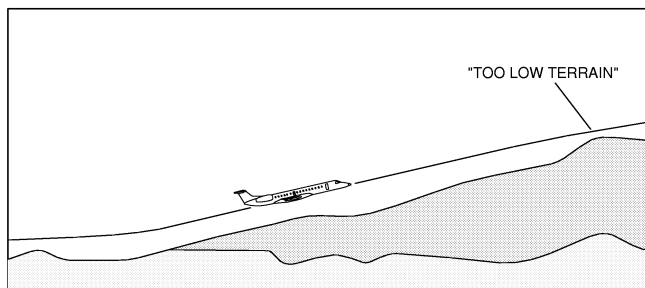
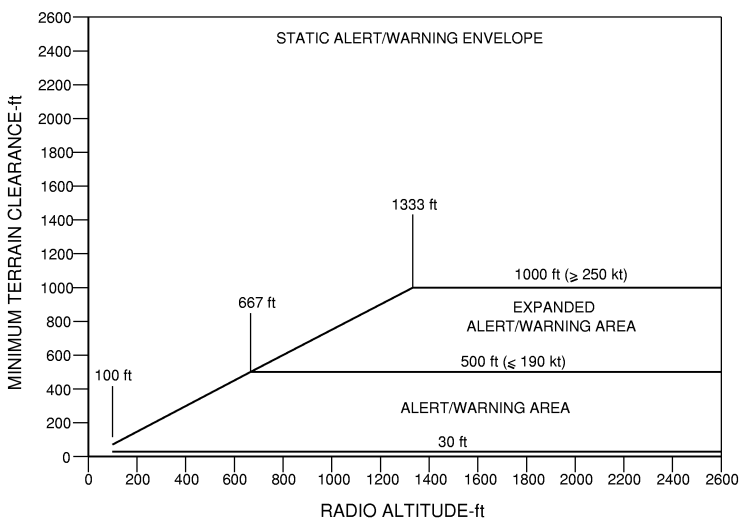

GPWS/EGPWS MODE 4C SCHEMATIC

MODE 5 - EXCESSIVE DEVIATION BELOW GLIDESLOPE BEAM

Mode 5 provides two levels of alerting if the airplane's flight path descends below the glideslope on ILS approaches.

Minimum Terrain Clearance (MTC) for "**GLIDESLOPE**" message triggering:

- Minimum:
 - For the Soft Alert Area, 30 ft at 2.98 dots of glideslope deviation.
 - For the Hard Alert Area, 30 ft at 3.68 dots of glideslope deviation.
- Maximum:
 - For the Soft Alert Area 1000 ft.
 - For the Hard Alert Area 300 ft.

The first alert occurs whenever the airplane is more than 1.3 dots below the beam and is called a "soft alert" because the volume level is reduced. A second alert occurs below 300 ft radio altitude with greater than 2 dots deviation from glideslope and is louder or "hard".

The aural message "**GLIDESLOPE**" is sounded once. Follow-on alerts are only allowed when the airplane descends lower on the glideslope beam by approximately 20%. Aural messages are sounded continuously once the airplane exceeds 2 dots.

The "**GPWS**" warning message is displayed on EICAS for airplanes equipped with GPWS and the amber "**GND PROX**" indication on the PFD for airplanes equipped with EGPWS.

The glideslope warning can be canceled by pressing the Master Caution Button.

MODE 5 EXCESSIVE GLIDE SLOPE DEVIATION

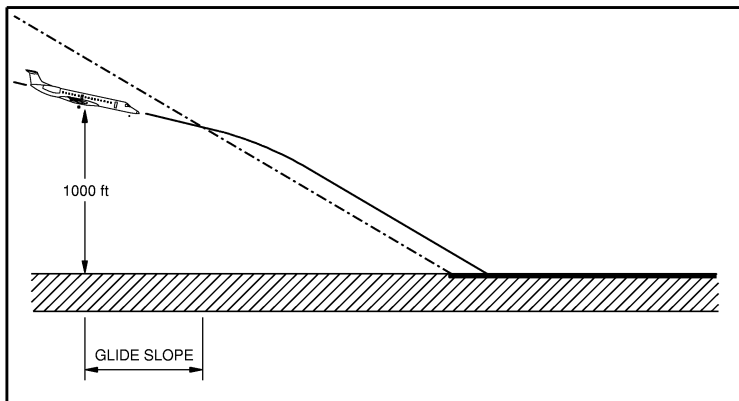
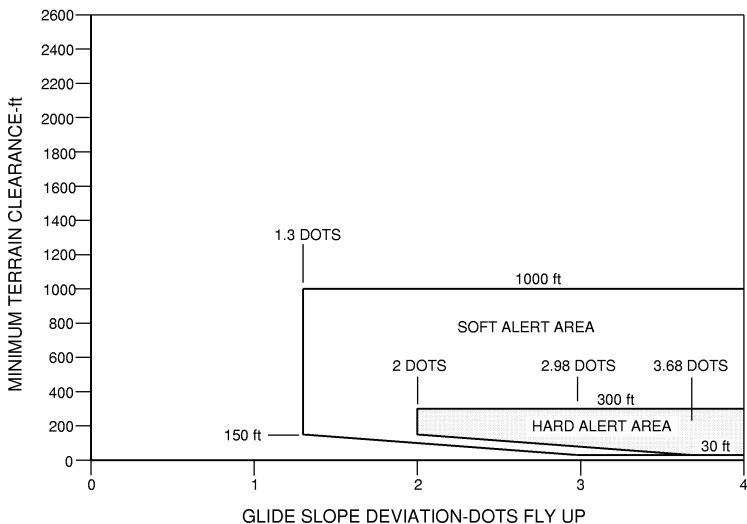

GPWS/EGPWS MODE 5 SCHEMATIC

MODE 6 - CALLOUTS

Mode 6 provides aural messages for descent below predefined altitudes, decision height, a minimums setting and approaching minimums. Alerts for excessive roll or bank angle are also provided.

There are two configurations of EGPWS callouts certified for the EMB-145 family.

	MINIMUMS CALLOUTS	ALTITUDE CALLOUTS
CONFIGURATION 1	"APPROACHING MINIMUMS" "MINIMUMS MINIMUMS"	"FIVE HUNDRED" "TWO HUNDRED" "ONE HUNDRED"
CONFIGURATION 2	"APPROACHING MINIMUMS" "MINIMUMS"	"ONE THOUSAND" "FIVE HUNDRED" "FOUR HUNDRED" "THREE HUNDRED" "TWO HUNDRED" "ONE HUNDRED" "FIFTY" "FORTY" "THIRTY" "TWENTY" "TEN"

MINIMUMS CALLOUTS

The message "**APPROACHING MINIMUMS**" is sounded only once when the airplane is 80 ft above the decision height or another target has been reached, with the landing gear down.

- Radio altitude for message triggering:
 - Minimum: 90 ft.
 - Maximum: 1000 ft.

The message "**MINIMUMS MINIMUMS**" or "**MINIMUMS**" is sounded only once when the airplane is at decision height or another target has been reached, with the landing gear down.

- Radio altitude for message triggering:
 - Minimum: 10 ft.
 - Maximum: 1000 ft.

Visual indication of minimum target is presented on PFD.

ALTITUDE CALLOUTS

The messages will be sounded when associated radio altitude has been reached, with the landing gear down.

For the Configuration 1, the "**FIVE HUNDRED**" message will only be sounded whether one or more of the following conditions are satisfied:

- ILS is not tuned or not available.
- ILS is tuned in a valid signal, but with a deviation greater than 2 dots of localizer or glideslope.
- If a backcourse approach is detected.

Radio altitude for message activation:

- Minimum: 50 ft.
- Maximum: 1000 ft.

BANK ANGLE CALLOUT

Minimum Terrain Clearance (MTC) for message triggering for GPWS:

- Minimum: 0 ft.
- Maximum: Increases linearly from 30 ft at 10° bank angle to 150 ft at 40° then from 150 ft at 40° up to 2450 ft at 40°.

Minimum Terrain Clearance (MTC) for message triggering for EGPWS:

- Minimum: 5 ft.
- Maximum: Increases linearly from 30 ft at 10° of bank angle to 150 ft at 40° then from 150 ft at 40° up to 2450 ft at 55°, remaining constant at 55° above 2450 ft.

The aural message "**BANK ANGLE, BANK ANGLE**" is sounded when the airplane bank angle is too high or roll rate exceeds 1°/sec during all phases of flight.

The message is generated again if bank angle increases by 20%.

For airplanes equipped with EGPWS, when roll attitude increases to 40% above the initial callout angle, the callout will repeat continuously.

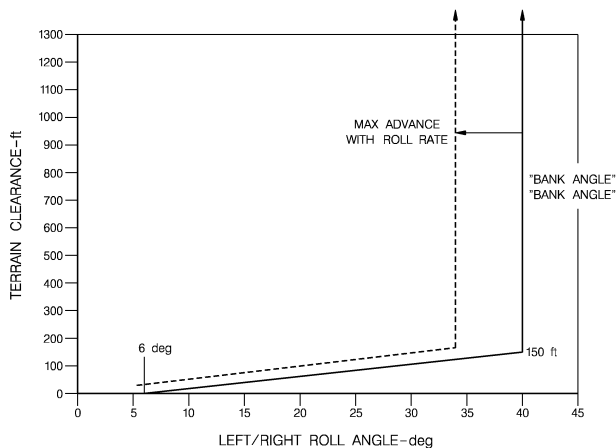

**GPWS MODE 6 - SCHEMATIC
BANK ANGLE CALLOUT**

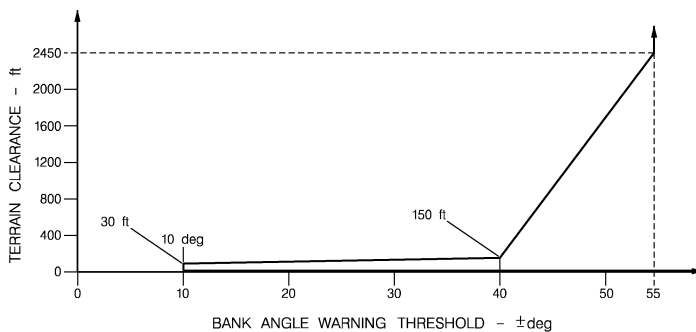

**EGPWS MODE 6 - SCHEMATIC
BANK ANGLE CALLOUT**

EGPWS FEATURES

The EGPWS incorporates GPWS functions with added features including the Terrain Clearance Floor, Terrain Look Ahead Alerting and Terrain Awareness Display. Airplanes equipped with EGPWS version 216 incorporates additional features like Peaks Mode, Runway Field Clearance Floor, Obstacle Alerting and Geometric Altitude.

TERRAIN CLEARANCE FLOOR

The Terrain Clearance Floor (TCF) provides a terrain clearance circular envelope around the airport runway, alerting the pilot of a possible premature descent for non-precision approaches regardless of the airplane's configuration. The TCF is active during takeoff, cruise and final approach and is based on current airplane position, nearest runway and radio altitude.

This alert mode complements the Mode 4 by providing an alert based on insufficient terrain clearance even when the airplane is in the landing configuration.

TCF alerts display **"GRND PROX"** on the PFD and the aural message **"TOO LOW TERRAIN"** sounds. This message sounds once when initial envelope penetration occurs and will repeat at every additional 20% decrease in radio altitude. The **"GRND PROX"** annunciator remains on until the TCF envelope is exited.

In the EGPWS version 216, the TCF alert provides an envelope extension for runway sides, which is limited to a minimum value of 245 ft beside the runway, within 1 NM to 2.5 NM from runway end. This feature provides improved alerting when it is determined that the aircraft is landing to the side of the runway.

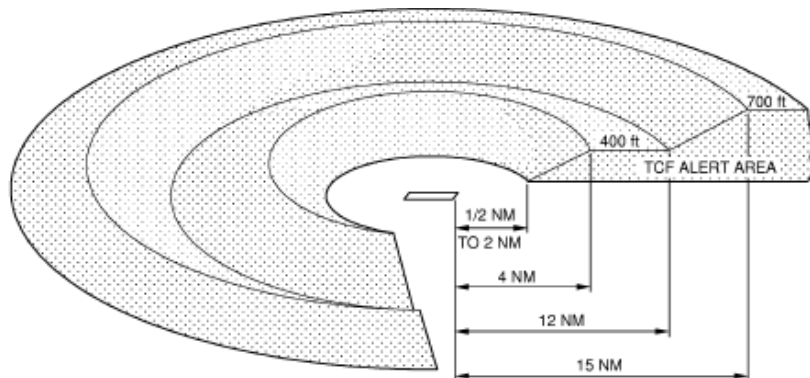

TCF ALERT ENVELOPE

TERRAIN LOOK AHEAD ALERTING

The Terrain Look Ahead Alerting provides a caution/warning level to alert the flight crew about potential terrain conflicts. The alerts are based mainly on the airplane's current position and barometric altitude information. In the event of terrain caution or warning conditions, a specific audio alert and visual alert are triggered and the terrain display image is enhanced to highlight each of the types of terrain threats.

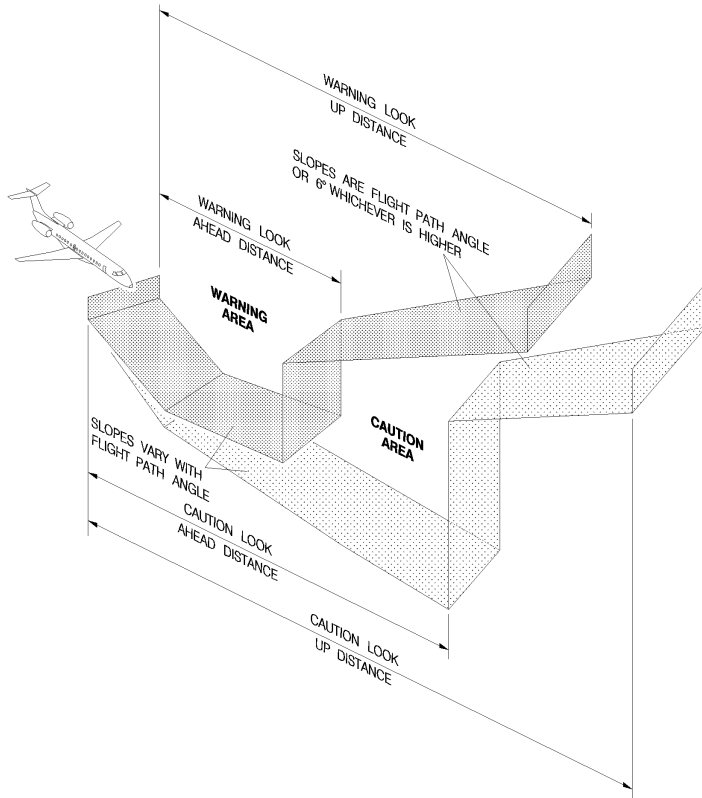

TERRAIN WARNING AND CAUTION AREAS

When conditions are such as to generate a Terrain Caution alert (approximately 60 seconds prior to potential terrain conflict), the aural message "**CAUTION TERRAIN, CAUTION TERRAIN**" is sounded and the amber "**GND PROX**" indication is displayed on the PFD. This is repeated every seven seconds as long as the airplane is still in the caution envelope.

When conditions have been met to generate a Terrain Warning alert (approximately 30 seconds prior to potential terrain conflict), the aural message "**TERRAIN, TERRAIN, PULL UP**" is sounded and the red "**PULL UP**" indication is displayed on the PFD.

The terrain image will appear automatically on the MFD when a terrain threat event occurs.

TERRAIN AWARENESS DISPLAY

The EGPWS terrain display is designed to increase flight crew awareness of the surrounding terrain in varying density dots patterns of green, yellow and red. These dot patterns represent specific terrain separation with respect to the airplane. The following table relates the color that the terrain is displayed with its meaning:

COLOR	MEANING
Solid red	Warning Terrain (Approximately 30 sec from impact).
Solid yellow	Caution Terrain (Approximately 60 sec from impact).
High density red dots	Terrain that is more than 2000 ft above airplane altitude.
High density yellow dots	Terrain that is between 1000 and 2000 ft above airplane altitude.
Medium density yellow dots	Terrain that is between 500 ft (250 ft with gear down) below and 1000 ft above airplane altitude.
Medium density green dots	Terrain that is between 500 ft (250 ft with gear down) to 1000 ft below airplane altitude.
Light density green dots	Terrain that is 1000 to 2000 ft below airplane altitude.
Black	Terrain below 2000 ft.

- NOTE:**
- Terrain is not shown if its elevation is within 400 ft of runway elevation of the nearest airport.
 - To reduce clutter on the display, any terrain more than 2000 ft below the airplane is not displayed.
 - Terrain that is not covered in the EGPWS database will be displayed in magenta.

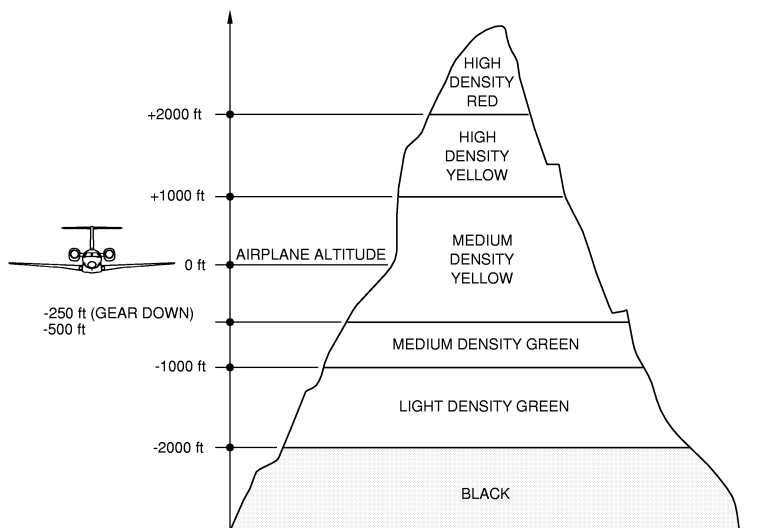

EGPWS DISPLAY COLOR CODING

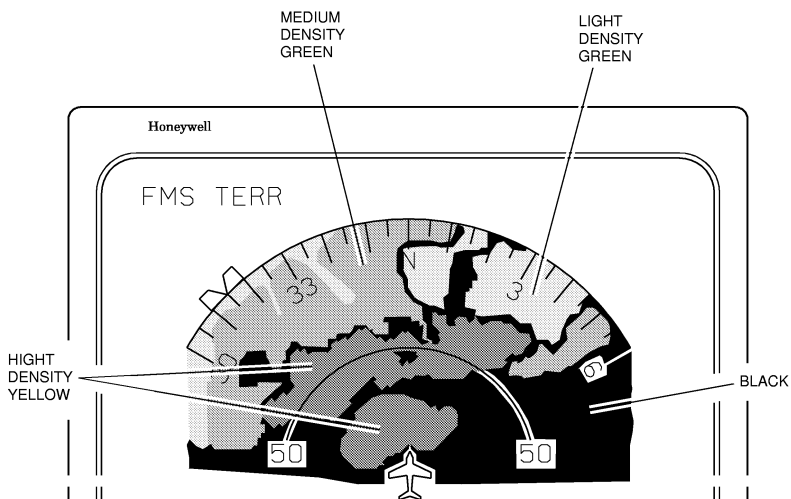

EXAMPLE OF EGPWS DISPLAY ON MFD

PEAKS MODE

This is a feature provided only by EGPWS version 216 and, when selected, adds additional density patterns and level thresholds to the standard mode display levels and allows the terrain to be displayed during the cruise phase even if it is more than 2000 ft below the aircraft.

When the Peaks display is on, elevation numbers indicating the highest and lowest terrain/obstacle currently being displayed are shown on the display. These elevations are expressed in hundreds of feet above sea level (MSL) with the highest elevation on top and the lowest on the bottom. In the event that there is no appreciable difference in the terrain/obstacle elevations, only the highest value is displayed.

The color of the elevation value displayed matches the color of the terrain displayed.

If the aircraft is 500 ft (250 ft with landing gear down) or less above the terrain in the displayed range, the peaks color displayed will be identical to the terrain awareness display mode, with the exception of sea level displayed as cyan.

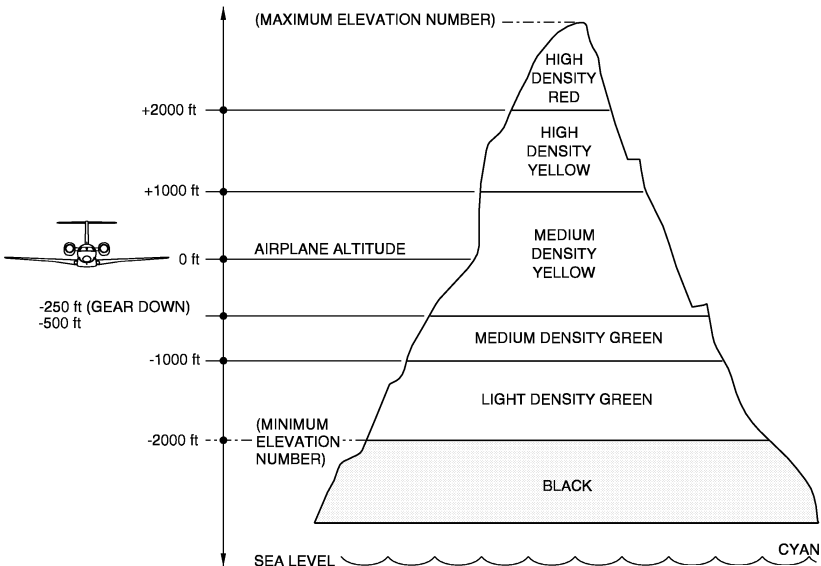

PEAKS PROFILE AT A LOW RELATIVE ALTITUDE

When the aircraft is greater than 500 ft (250 ft with landing gear down) above all terrain in the displayed range, no yellow or red bands are displayed and low density green, medium density green and solid green will be displayed as a function of the highest and lowest elevations in view. Moreover, sea level elevations can be displayed as cyan to simulate water.

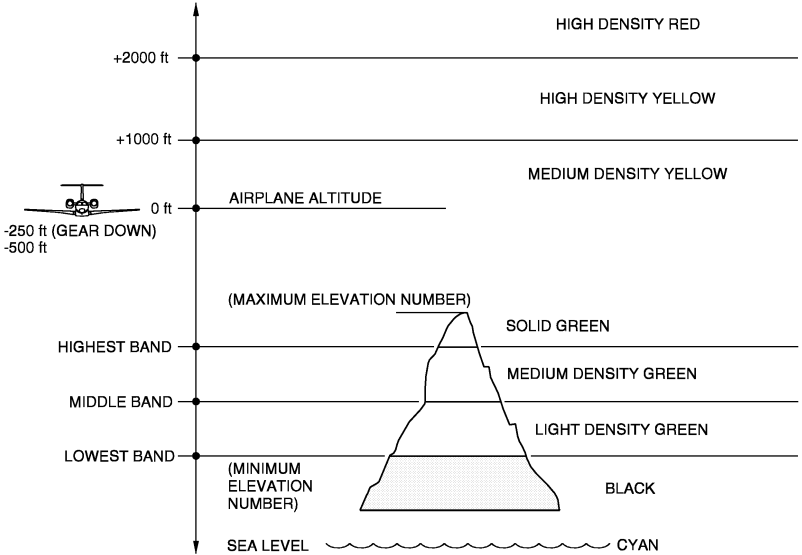

PEAKS PROFILE AT A HIGH RELATIVE ALTITUDE

RUNWAY FIELD CLEARANCE FLOOR

Runway Field Clearance Floor (RFCF) is a second clearance floor in addition to TCF in EGPWS version 216. While TCF uses radio altitude, RFCF determines the aircraft height above the runway using geometric altitude by subtracting the elevation of the selected destination runway from the current altitude (MSL). This feature provides improved alerting for cases where the runway is at a high elevation compared to the terrain below the approach path.

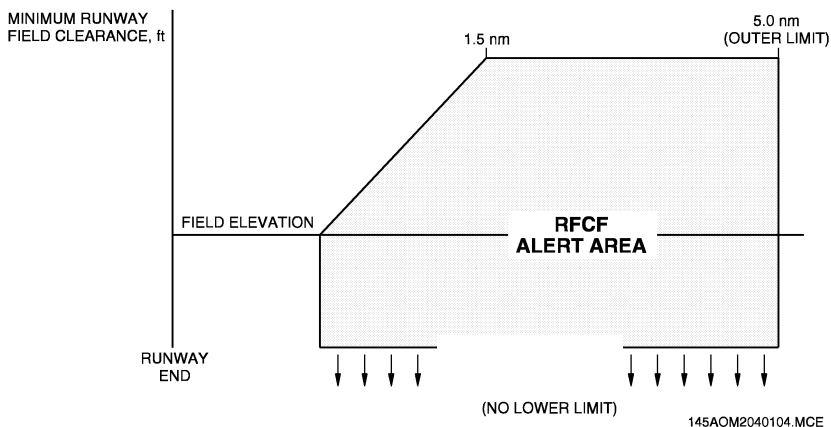

RFCF ALERT ENVELOPE

RFCF alerts display “**GRND PROX**” on the PFD and the aural message “**TOO LOW TERRAIN**” sounds. This message sounds once when initial envelope penetration occurs and will repeat at every additional 20% decrease in radio altitude.

OBSTACLE ALERTING

A database of man-made obstacles is stored internal to the EGPWS version 216. The terrain "cell" on which the obstacle resides is coded as an obstacle with an elevation equal to the obstacles MSL height. The same software algorithms that detect and display terrain conflict are used to detect and display obstacle conflict. If any obstacle is "seen" in the database by the algorithms, annunciators are illuminated and voice "**CAUTION OBSTACLE**" sounds approximately 45 seconds prior to potential terrain conflict and the aural "**OBSTACLE OBSTACLE PULL UP**" sounds approximately 30 seconds prior to potential terrain conflict.

GEOMETRIC ALTITUDE

EGPWS version 216 and on uses Geometric Altitude algorithm to determine aircraft altitude. The Geometric Altitude computation uses an improved pressure altitude calculation, GPS altitude, radio altitude, terrain and runway elevation data to reduce or eliminate errors potentially induced in corrected barometric altitude by temperature extremes, non-standard altitude conditions and altimeter miss-sets. Geometric Altitude also allows continuous EGPWS operations in QFE environments without custom inputs or special operational procedures.

WARNING PRIORITIES

The GPWS/EGPWS warning priorities are listed below. Messages at the top will start before or override a lower priority message even if it is already in progress.

MESSAGE	MODE
PULL UP	1 and 2
TERRAIN TERRAIN	2 and Terrain Look-Ahead
PULL UP	Terrain Look-Ahead
TERRAIN	2
MINIMUMS MINIMUMS	6
CAUTION TERRAIN	Terrain-Look Ahead
TOO LOW TERRAIN	4 and Terrain Clearance Floor
ALTITUDE CALLOUTS	6
TOO LOW GEAR	4
TOO LOW FLAPS	4
SINKRATE	1
DON'T SINK	3
GLIDESLOPE	5
APPROACHING MINIMUMS	6
BANK ANGLE	6

EICAS MESSAGES**GPWS**

TYPE	MESSAGE	MEANING
WARNING	GPWS	One GPWS envelope, associated to Modes 1 to 4, has been penetrated.
CAUTION	GPWS INOP	GPWS monitor has detected an internal failure.

EGPWS

TYPE	MESSAGE	MEANING
WARNING	GPWS	One GPWS envelope, associated to Modes 1 to 4, has been penetrated.
CAUTION	GPWS INOP	GPWS monitor has detected an internal failure.
	TERR INOP	Terrain mode is not available.

CONTROLS AND INDICATORS

1 - EGPWS TERRAIN SYSTEM OVERRIDE BUTTON

- When pressed, inhibits EGPWS in approach mode, thus avoiding unwanted terrain alerts in airports not covered by EGPWS database.

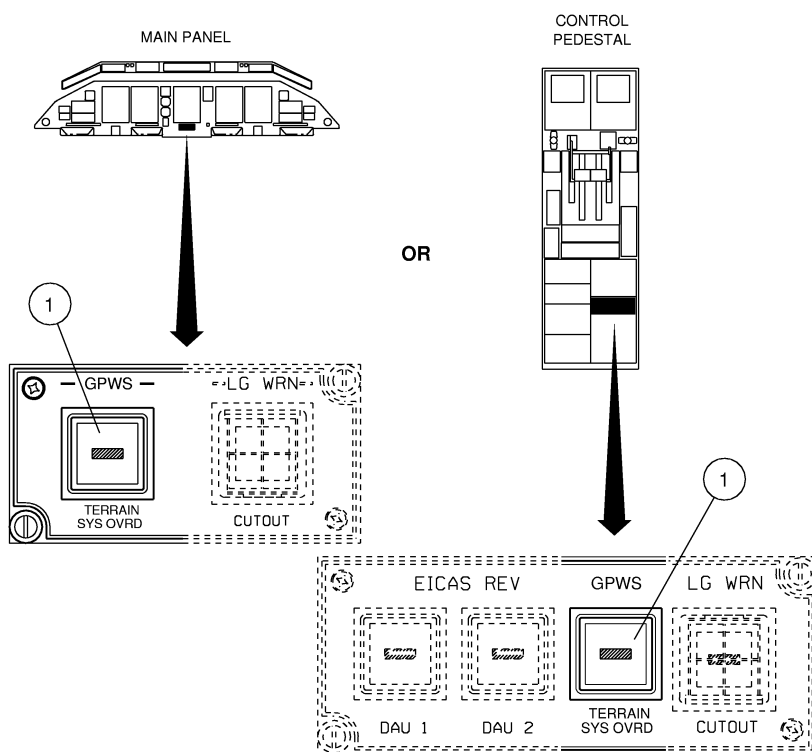

145AOM2040046.MCE A

EGPWS TERRAIN SYSTEM OVERRIDE BUTTON

MFD BEZEL PANEL

1 - EGPWS DISPLAY SELECTOR BUTTON

- Alternate pressing will cause the MFD to toggle between the weather radar or terrain to be displayed.
- The ranges allowed are: 5 NM, 10 NM, 25 NM, 50 NM, 100 NM, 200 NM, 300 NM, 500 NM and 1000 NM.
- When a terrain warning/caution condition exists and the terrain is not selected on the MFD, the terrain will be automatically displayed on the MFD with a range of 10 NM.

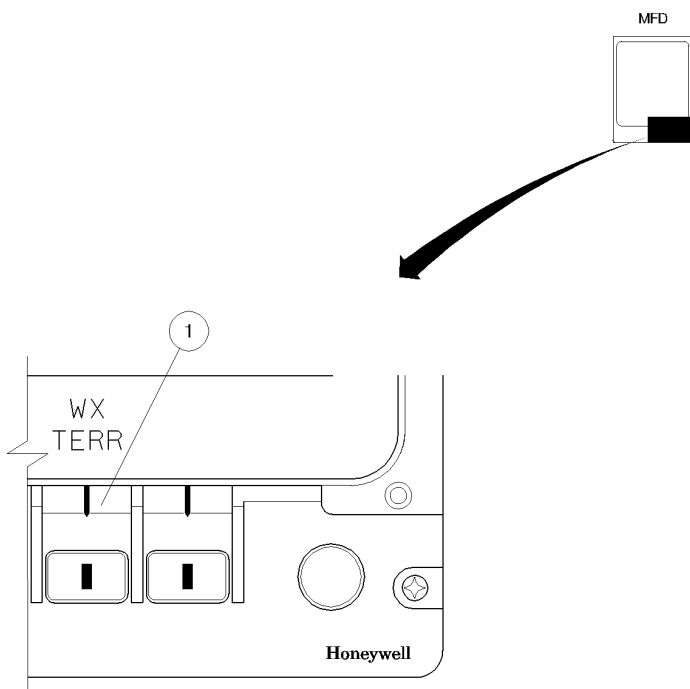

MFD BEZEL PANEL

EGPWS DISPLAY ON MFD**1 - TERRAIN ANNUNCIATIONS**

LABEL	COLOR	CONDITION
TERR (Upper left corner)	Cyan	Lit when terrain mode is selected.
TERR FAIL	Amber	Lit when terrain mode is inoperative.
TERR INHIB for Terrain Inhibition	White	Lit when the EGPWS terrain system override button is pressed in approach mode.
TERR N/A	Amber	Lit when EGPWS is uncertain of the airplane's position.
TERR TEST	Red	Lit when the self test is activated.
TERR (Center)	Amber	Lit when terrain picture bus fails (Airplanes equipped with EICAS version 15).

2 - TERRAIN INDICATION

- Displays an image of surrounding terrain in varying density dot patterns of green, yellow and red. These dot patterns represent specific terrain separation with respect to the airplane. The display is generated from airplane altitude compared to terrain data.

3 - TERRAIN ALERT INDICATION

- Indicates a terrain warning or caution condition.

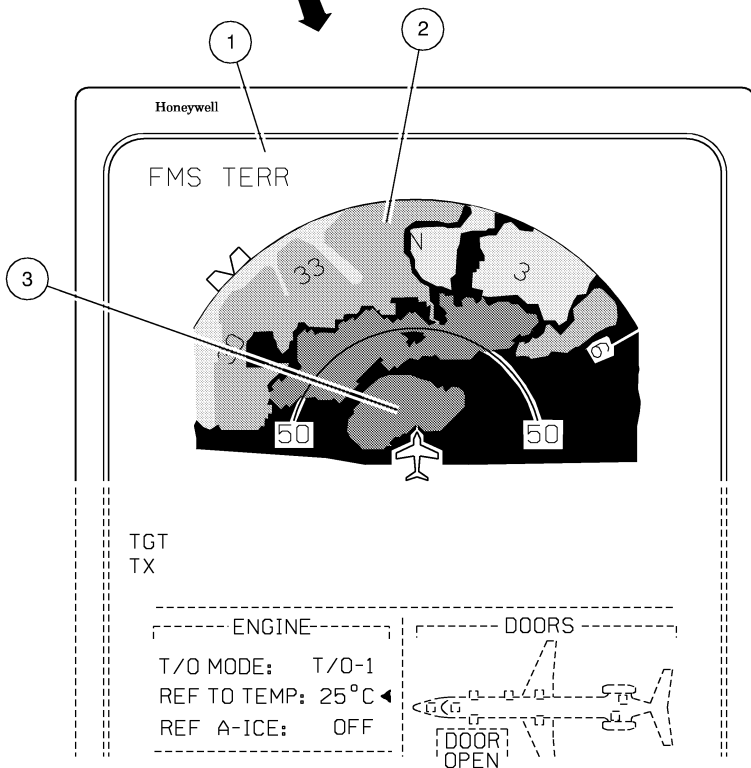
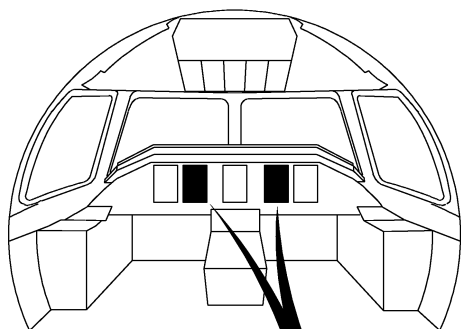

EGPWS DISPLAY ON MFD

DISPLAY ON PFD

GPWS

Refer to Flight Instruments.

EGPWS

1 - PULL UP/GROUND PROXIMITY ANNUNCIATIONS

- Label: PULL UP (red)
GND PROX for Ground Proximity (amber).
- PULL UP is lit when either modes 1 or 2 have been activated in their more critical situation.
- GND PROX is lit when ground is getting closer too fast.

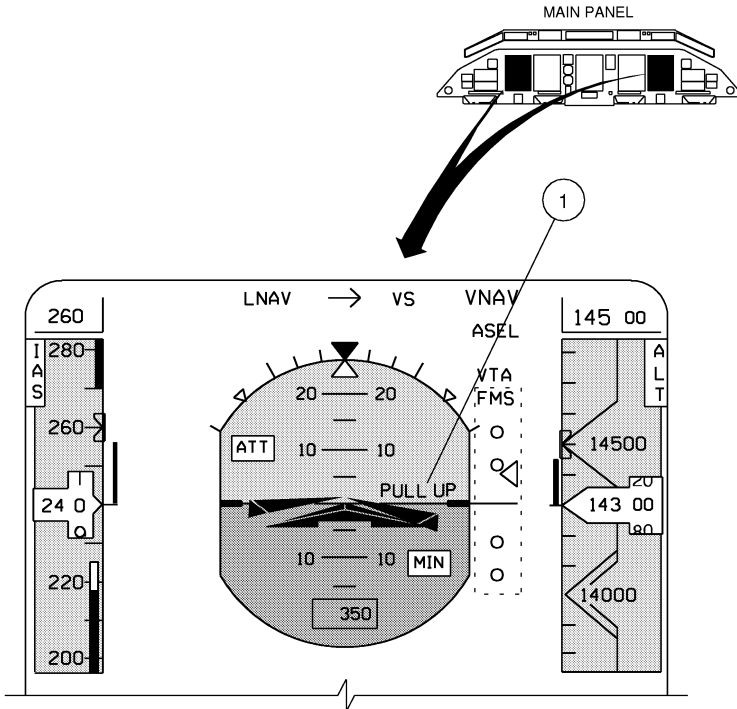

EGPWS DISPLAY ON PFD

STEEP APPROACH OPERATION

Some airplanes may be optionally equipped with Steep Approach function. Steep approaches are approach operations performed with glide slope angle above 4.4 degrees. This kind of operation implies to the airplane a vertical speed higher than the normal, requiring means to change the range of the EGPWS Mode 1 envelope in order to avoid nuisance messages.

The Steep Approach mode is selected by means of two pushbuttons installed on the glareshield panel, one at each side. When either pushbutton is pressed, an internally preset mode of the EGPWS changes the references to sound the SINK RATE and PULL UP aural warnings.

When the airplane is in flight and the flaps are selected to 45°, the STEEP white light illuminates on the Steep Approach pushbutton indicating that the Steep Approach mode is available. When either the flaps are retracted to a position other than 45° or airplane lands, the STEEP white light extinguishes indicating that the Steep Approach mode is no longer available.

The pushbutton lower portion has two status lights, amber and green. The green light indicates that the Steep Approach mode is engaged and the amber light indicates a failure condition.

If the amber light turns on, it indicates that the Steep Approach mode is failed and steep approach operations must not be performed. In this situation, the Steep Approach mode is not engaged and the airplane must land in an airport that does not require steep approach operation.

In flight, with the STEEP inscription illuminated if the Steep Approach pushbutton is pressed, the green light illuminates to indicate that the Steep Approach mode is engaged. If the green light does not illuminate, the Steep Approach mode is not engaged and the steep approach operation must not be performed.

The Steep Approach mode is deselected pressing the pushbutton or through automatic deselection. An automatic deselection of the Steep Approach mode is performed when:

- Airplane on the ground;
- Flaps setting other than 45°.

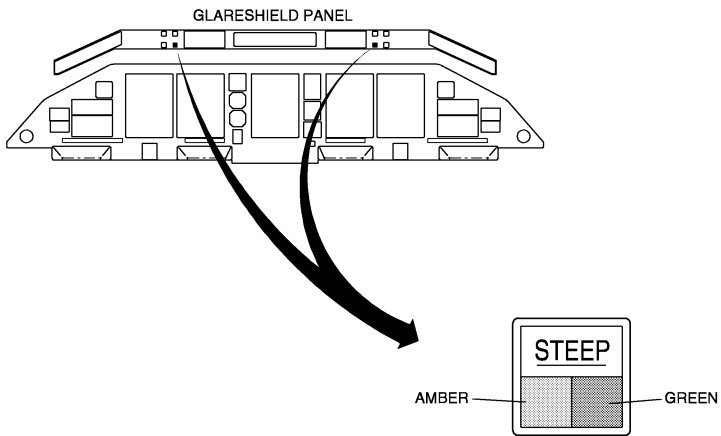

STEEP APPROACH MODE PUSHBUTTON

CONTROLS AND INDICATORS**STEEP APPROACH PUSHBUTTON**

LIGHT INDICATION	MODE DESCRIPTION
STEEP	Illuminates in white color when the airplane is in the air and the flaps are in 45°. This means that the Steep Approach mode is available.
GREEN LIGHT	Illuminates when the button is pressed with the STEEP light illuminated. This means that the Steep Approach mode is engaged. With the STEEP light illuminated, if the green light does not illuminate when the pushbutton is pressed, means that the Steep Approach is not engaged; in this case, do not perform Steep Approach operations.
AMBER LIGHT	The Steep Approach mode is failed. Do not perform Steep Approach operations. In this situation, the Steep Approach mode is not engaged and the airplane must land in an airport that not requires steep approach operation.

WINDSHEAR DETECTION AND ESCAPE GUIDANCE SYSTEM

The EMB-145 is equipped with an additional warning system dedicated to windshear detection. The system provides visual and aural alarms to warn pilots of a windshear occurrence, as well as the most appropriate maneuver to recover from such phenomenon.

The Windshear Detection function is performed by the EGPWS computer, which also performs ground proximity warning functions. The Windshear Escape Guidance is a Flight Director mode provided by the avionics package.

WINDSHEAR GENERAL INFORMATION

Windshear is a sudden change in wind direction or speed, normally caused by thunderstorms, frontal systems or any topographical feature that may affect the wind flow (e.g. hills, mountains, lakes, seas etc...).

Due to ground proximity, the most hazardous phases of flight regarding windshear encounters are takeoff, approach and landing. On a windshear, wind may shift from a tailwind to a headwind or to a downdraft or updraft. The consequences may be an abrupt change in airspeed, lift and altitude, upwards or downwards, according to shifting direction. Although quick, windshear is not instantaneous, which may lead pilots to correction attempts in the wrong manner. For instance, an airplane facing a headwind after takeoff, appears to have good performance, characterized by high airspeed, which drives the pilot into rotating the airplane to a pitch higher than usual. When the thunderstorm core is reached, wind shifts to a downdraft and airspeed decreases, as well as vertical speed. The pilot's natural reaction is to lower the airplane's nose in an attempt to maintain airspeed. Further ahead, wind shifts to tailwind component, resulting in a dramatic airspeed reduction with the nose already down. Under such scenario, it is very difficult to maintain a positive rate of climb.

If the takeoff or landing can not be delayed, the correct action is to increase airspeed before being subjected to windshear encounter and to consider flying near stall speeds with high angle of attack if necessary to regain altitude.

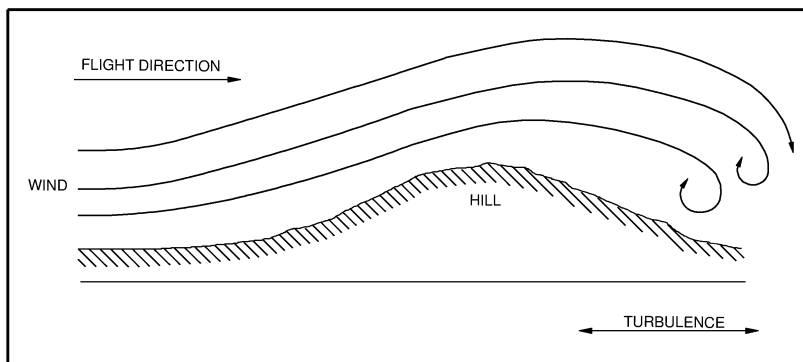
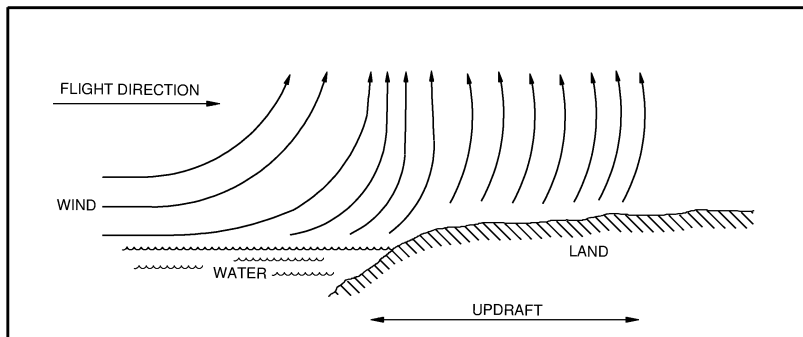
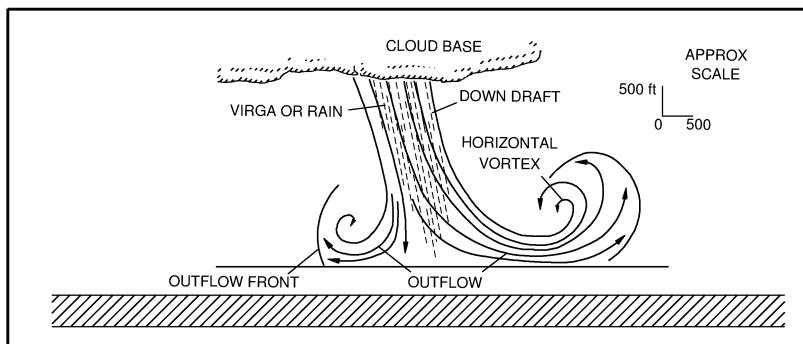

KINDS OF WINDSHEAR

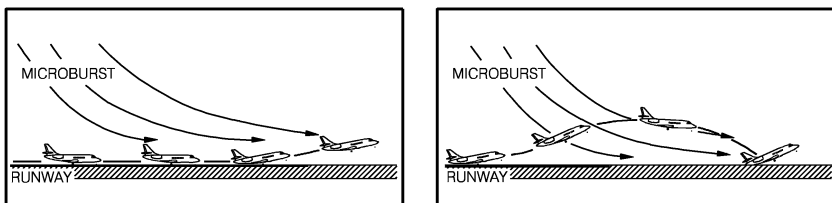

WINDSHEAR EFFECT DURING TAKEOFF

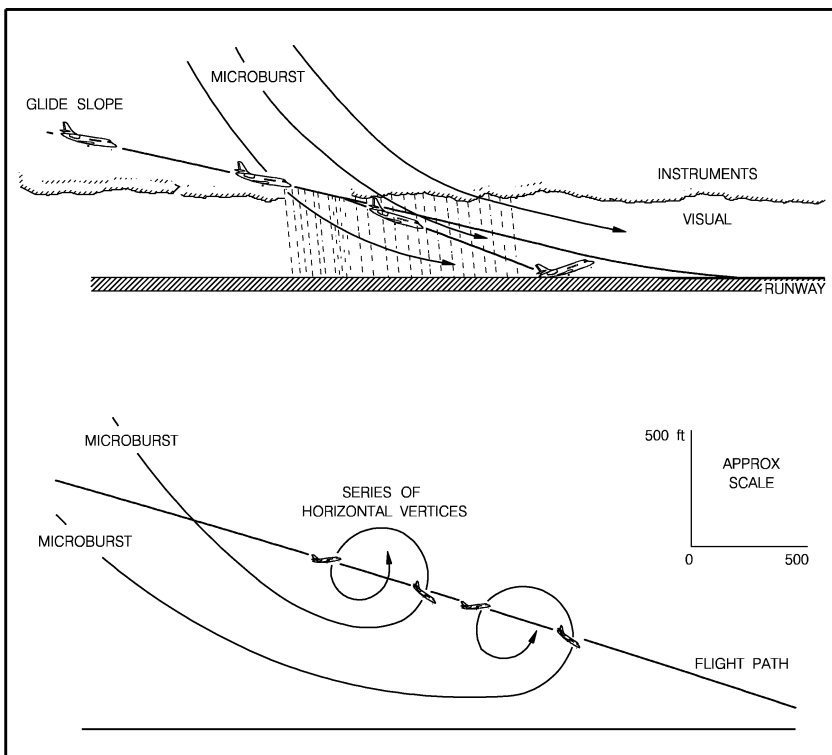

WINDSHEAR EFFECT DURING LANDING

WINDSHEAR EFFECTS

WINDSHEAR DETECTION

The windshear detection system is designed to identify the presence of severe windshear phenomenon and to provide timely warnings and adequate flight guidance for approach, missed approach, takeoff and climb out.

The windshear computer exchanges data with AHRS, ADC, SPS, Radio Altimeter and IC-600s. The system continuously searches for any windshear clue, and then signals the PFD and aural warning unit to provide the appropriate indications.

Windshear Caution alerts are given if the windshear consists of an increasing headwind (or decreasing tailwind) and/or severe updraft, which may precede an encounter with a microburst. Windshear cautions activate the Windshear Caution (WDSHEAR) amber indications on the upper left corner of both PFDs. On airplanes equipped with EGPWS, an aural message "CAUTION WINDSHEAR" is also triggered. Windshear Caution indications remain on for as long as the airplane remains exposed to an increasing headwind and/or updraft condition in excess of the alert threshold.

Windshear Warnings are given if the windshear consists of a decreasing headwind (or increasing tailwind) and/or severe downdraft. Windshear warnings activate the Windshear Warning (WDSHEAR) red indication on both PFDs and trigger an aural message "WINDSHEAR, WINDSHEAR, WINDSHEAR". This message will not be repeated unless another, separate, severe windshear event is encountered. Windshear Warning indications remain on for as long as the airplane remains exposed to a decreasing headwind and/or downdraft in excess of the alert threshold. The threshold is adjusted in function of available climb performance, flight path angle, airspeeds significantly different from normal approach speeds and unusual fluctuations in Static Air Temperature (typically associated with the leading edges of microbursts).

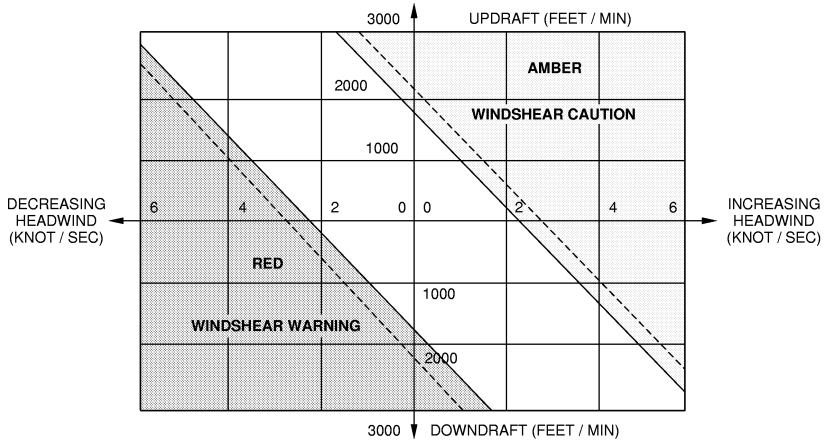

WINDSHEAR DETECTION

WINDSHEAR ESCAPE GUIDANCE MODE

The Windshear Escape Guidance mode is used to minimize altitude and speed loss during a windshear encounter. The strategy is to keep the airplane airborne until the windshear conditions subside or are exited.

The Windshear Escape Guidance Mode provides pitch command to recover from a windshear encounter. The amplitude of the pitch command will depend upon the airplane's performance and windshear severity and phase.

The Windshear Escape Guidance is a Flight Director mode engaged under the following conditions:

- Manually, by pressing the Go Around Button while a windshear condition (increasing/decreasing performance) is detected;
- Automatically, when in Go Around or Takeoff Mode and a windshear condition (increasing/decreasing performance) is detected;
- Automatically, when Thrust Levers Angle is above 78° and a decreasing performance windshear is detected (windshear warning).

When the windshear escape guidance mode is engaged a green "WSHR" indication is displayed on both PFDs in the Vertical Mode field and a "ROLL" indication is displayed in the Lateral Mode field. Whenever the Windshear Escape Guidance mode is engaged, the Pitch Limit Indicator (PLI) symbol is drawn directly on the Attitude Display Indicator portion of the PFD. The PLI represents the remaining angle of attack margin before Stick Shaker triggering.

All other Flight Director modes are canceled and the following vertical modes are inhibited when a caution or warning windshear condition is presented:

- Altitude Preselect Mode, Go Around and Takeoff.

No lateral modes are inhibited while in the vertical mode of WSHR.

The Windshear Escape Guidance mode is designed to meet the following requirements, in the listed order of priorities:

- Prevent the airplane from stalling;
- Prevent the airplane from descending;
- Prevent the airplane from exceeding V_{MO} .

The Windshear Escape Guidance Mode incorporates three control sub-modes:

- Alpha Sub-mode - The airplane can be commanded to descend in order to maintain airspeed when approaching stall conditions. If the flight path angle control results in an angle of attack beyond the stick shaker triggering angle, the windshear control law can keep the airplane angle of attack below the stick shaker threshold.
- Gamma Sub-mode - The airplane can be prevented from descending by commanding a positive flight path angle. A nominal flight path angle is used to allow an airspeed raise during an increasing performance windshear, in anticipation of a decreasing performance windshear, and also to minimize altitude loss during a decreasing performance windshear.
- Speed Target Sub-mode - The airplane is allowed to climb in order to exchange excessive kinetic energy for potential energy. If the control of the flight path angle results in an excessive speed increase, the windshear control law maintains the airplane indicated airspeed at the target speed.

The Windshear Escape Guidance mode will be canceled if any of the following conditions occur:

- FLC, VS, SPD or ALT Mode is selected;
- Invalid AHRS data;
- Invalid ADC data;
- Invalid Stall Protection Computer (SPC);
- Radio Altitude greater than 1500 ft.

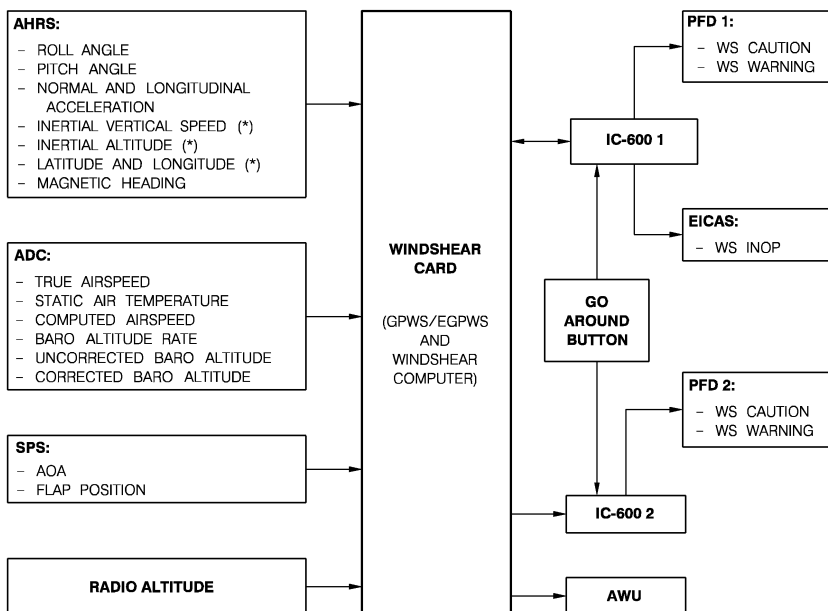

NOTE: (*) ONLY FOR AIRPLANES
EQUIPPED WITH EGPWS.

WINDSHEAR DETECTION AND ESCAPE GUIDANCE SYSTEM SCHEMATIC

EICAS MESSAGE

TYPE	MESSAGE	MEANING
CAUTION	WINDSHEAR INOP	Windshear detection and escape guidance system is inoperative.

CONTROLS AND INDICATORS

PRIMARY FLIGHT DISPLAY

1 - WINDSHEAR INDICATION

- Indicates that a windshear has been detected.
- Color: amber or red depending on windshear severity.

2 - ESCAPE GUIDANCE MODE ENGAGEMENT ANNUNCIATION

- Indicates the Windshear Flight Guidance Escape Mode engagement.

3 - PITCH LIMIT INDICATOR

- Refer to Stall Protection System indicators

4 - FLIGHT GUIDANCE INDICATION

- Indicates the appropriate pitch to be attained, during a windshear occurrence.

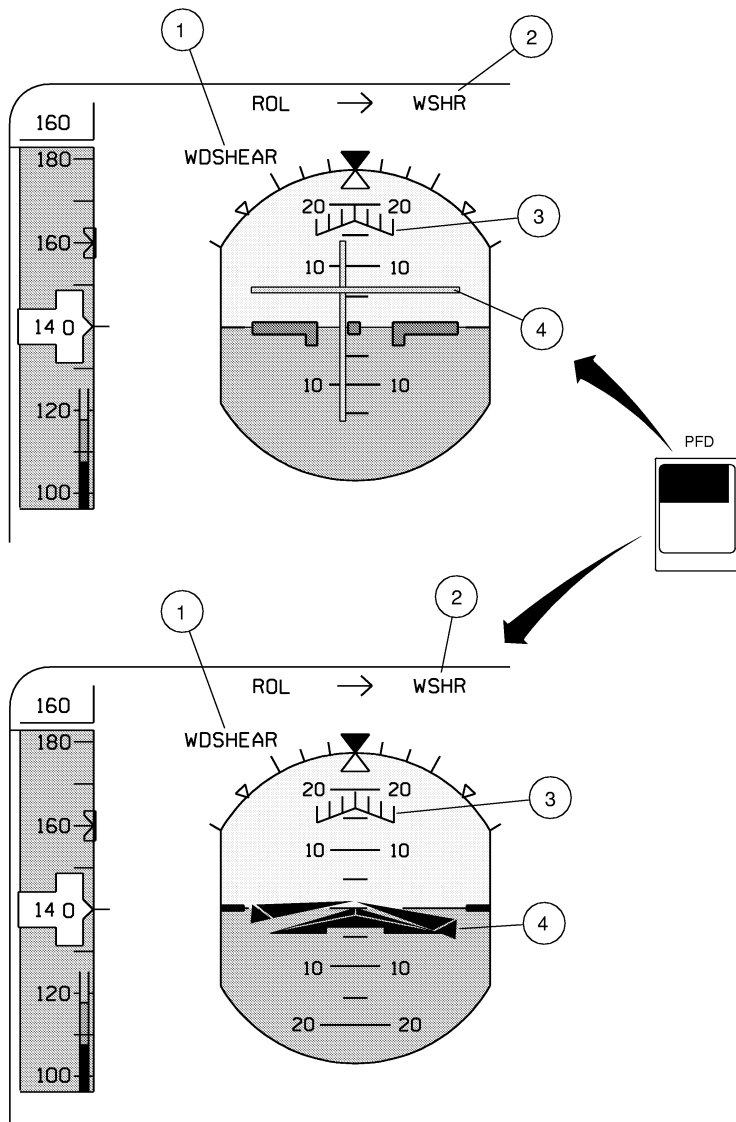

**PRIMARY FLIGHT DISPLAY
(V-BAR AND CROSS-BAR FORMAT)**

TRAFFIC AND COLLISION AVOIDANCE SYSTEM

GENERAL

The EMB-145 is equipped with a Traffic and Collision Avoidance System (TCAS), which provides the flight crew with an indication of possible in-flight traffic conflict. The system is based upon transponder signals and provides visual and aural warnings, as well as recommended evasive action.

The EMB-145 may be equipped with TCAS software version 6.04A (TCAS II and TCAS 2000) or with TCAS software version 7.0 (TCAS 7).

The TCAS 2000 presents the same operational characteristics of the TCAS II.

The TCAS 7 presents the following differences when compared to the TCAS II or TCAS 2000:

- The altitude separation thresholds for issuing Traffic Advisory (TA) and Resolution Advisory (RA) between FL300 and FL420 are reduced for compatibility with RVSM flight operations.
- The thresholds for issuing RA for airplanes closing in altitude are reduced between the FL200 and FL420.
- Reduction in the numbers of RA eliminating those airplanes that are expected to pass with sufficient horizontal range separation.
- Allows RA direction reversion, i.e, change a CLIMB to a DESCENT and vice-versa in coordination with another TCAS equipped airplane.
- Introduction of three additional RA.
- Different set points and range of actuation, as presented in the text below.

SYSTEM DESCRIPTION

The TCAS was developed to provide crew awareness regarding possible conflicting air traffic situations. Besides providing awareness, TCAS also displays to the flight crew the recommended vertical maneuver to avoid conflicting traffic. TCAS does not provide recommendations for horizontal maneuvers.

CAUTION: PRIMARY RESPONSIBILITY FOR EVASIVE ACTION LIES WITH THE FLIGHT CREW AND ANY ACTION MUST ALWAYS BE PRECEDED BY A VERY CAREFUL EVALUATION OF THE SITUATION.

The TCAS computer receives data from the installed transponders, radio altimeters and air-ground sensor. The signals transmitted by surrounding airplanes inform their altitude, bearing and identification, thus making it possible to track any traffic that could enter the airplane's protection zone. Based on such data, the TCAS calculates the predicted path of each intruder airplane, determining whether or not it may become a target. To determine that, an alert zone is established, based on separation and speeds of both airplanes. The size of the alert zone is not distance-based but, rather, is based on time. Therefore, the caution area corresponds to the volume in space where a conflict is expected to occur in 35 to 45 seconds, if no action is taken. A warning area corresponds to an imminent conflict in the following 20 to 30 seconds. Such time is calculated by dividing distance between airplanes by their closure rate.

To inhibit the issuing of undesired warnings that constitute a nuisance effect, the system incorporates a series of protections. These apply during approaches to crowded airports, to increase protection against slow closure rates, and to prevent airplanes below 180 ft (380 ft for TCAS 7), which are about to land or have just taken-off, from creating a nuisance.

When an airplane is tracked by the TCAS, the system periodically interrogates the intruder's transponder. The exchange of data between two subsequent transmissions makes it possible to obtain the distance to the intruder and its altitude, and to predict its path.

If the predicted path of the intruder enters the airplane's alert area, two kinds of alerts may be generated. If the area to be penetrated is the caution area, a Traffic Advisory (TA) is generated. Pilots are then requested to visually locate the intruder and perform the required preventive action.

If the warning area is penetrated a Resolution Advisory (RA) is generated, as well as the corrective action that must be taken to permit the greatest possible separation at the Closest Point of Approach (CPA). Sometimes, the recommended action may lead to crossing of the intruder's flight level or may change during the maneuver. This situation may occur when the calculation indicates that this is the best way to achieve the greatest possible separation at the CPA. For both advisory cases, a symbol is presented in the MFD to indicate the intruder's relative position, altitude and danger level. A voice message is generated to help the pilots in taking the most suitable action. The PFD provides indication of the recommended vertical speed to clear the conflict. A voice message may be generated to warn the pilot into monitoring the VSI on the PFD. When TCAS computations indicate that the traffic has been cleared, a voice message advises pilots that there is no longer a conflicting situation. In this condition, if no other TA or RA is on course, the intruder's indication changes, indicating that it is a safe nearby traffic.

If the intruder is also equipped with a TCAS, maneuvers are coordinated between both airplanes. If the intruder is only equipped with a transponder, the system may still indicate its position, provided its transponder is at least mode C. For airplanes equipped with mode A transponder, only Traffic Advisories may be generated.

CAUTION: THE TCAS CAN ONLY GENERATE RESOLUTION ADVISORIES FOR INTRUDERS EQUIPPED WITH RESPONDING MODE S OR MODE C TRANSPONDERS. TRAFFIC ADVISORIES CAN BE GENERATED FOR AIRPLANE WITH OPERATIVE MODE S, MODE C OR MODE A TRANSPONDERS. THE TCAS PROVIDES NO INDICATION OF AIRPLANE WITHOUT OPERATING TRANSPONDERS.

System options may be monitored and set through the RMU. A dedicated window is provided, presenting which TCAS display is being controlled, its range and altitude band. A RMU page permits toggling between options. Controls allow selection of different ranges, either horizontal and vertically, as well as changing the way some parameters are presented.

For airplanes Post-Mod. SB 145-34-0089 or equipped with an equivalent modification factory incorporated, the Mode S Elementary Surveillance Transponder transmits the following parameters:

- Airplane Identification (Call Sign);
- Capability Report;
- Flight Status (airborne/on the ground);
- Pressure Altitude with 25 ft of resolution.

For airplanes equipped with Mode S Enhanced Surveillance Transponder (Post-Mod. SB 145-34-0096 or equipped with an equivalent modification factory incorporated), in addition to the characteristics of the Mode S Elementary, the following Downlink Airplane Parameters (DAP) are transmitted automatically to be used by the ground Air Traffic Management:

- Magnetic Heading;
- Indicated Airspeed;
- Mach Number;
- Vertical Rate;
- Roll Angle;
- True Track Angle;
- Ground Speed;
- Selected Altitude.

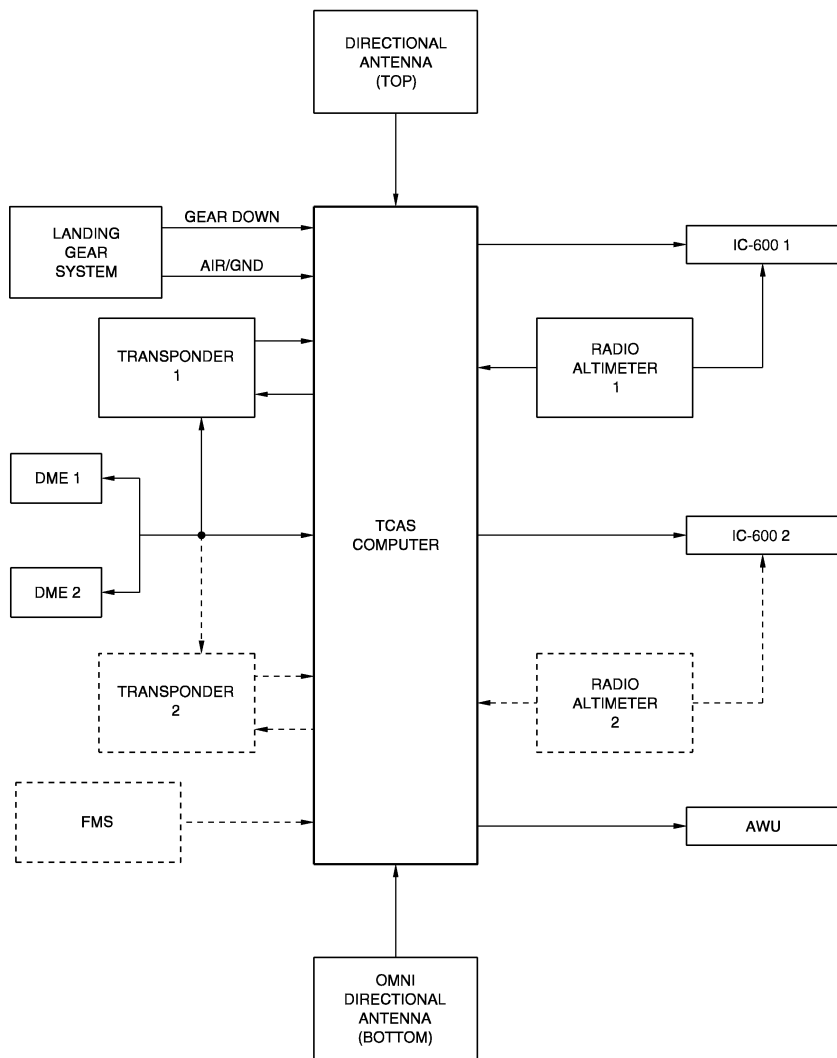

TCAS SCHEMATIC

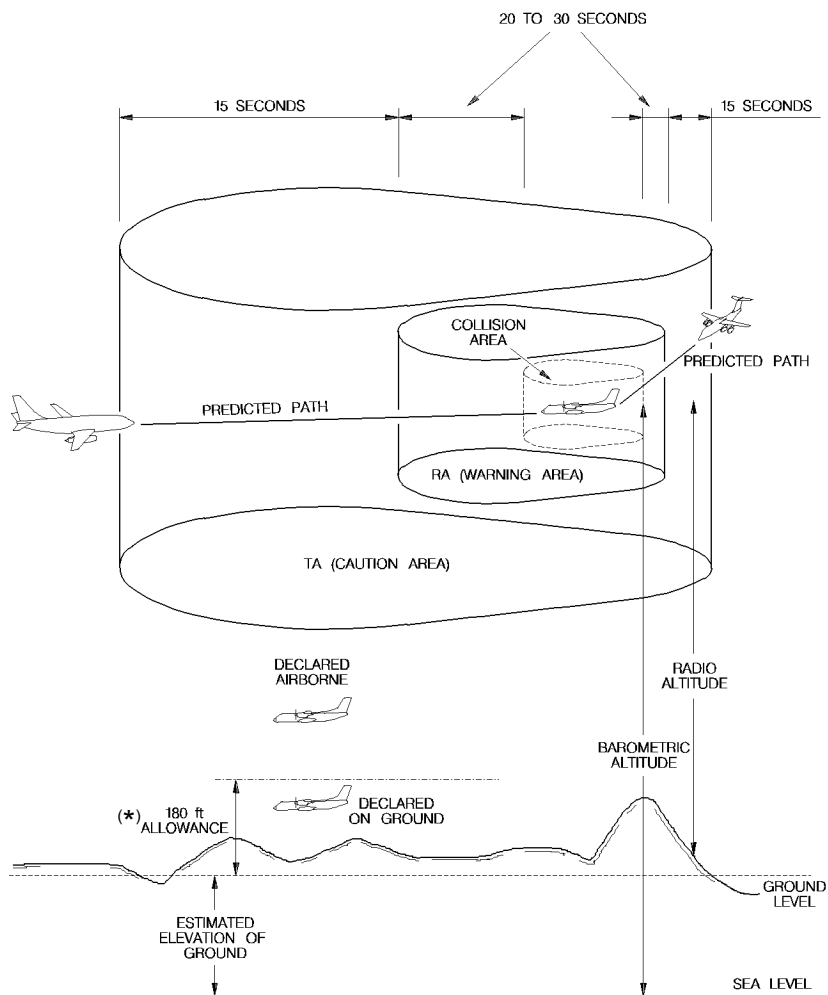

(*) 380 ft for TCAS 7.

TCAS PROTECTED AREAS

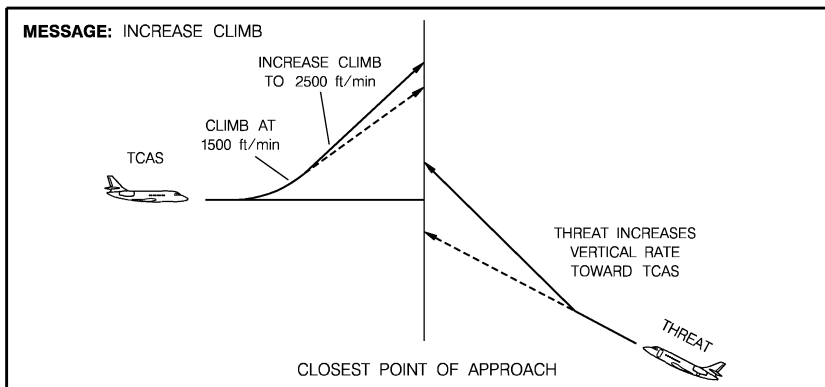
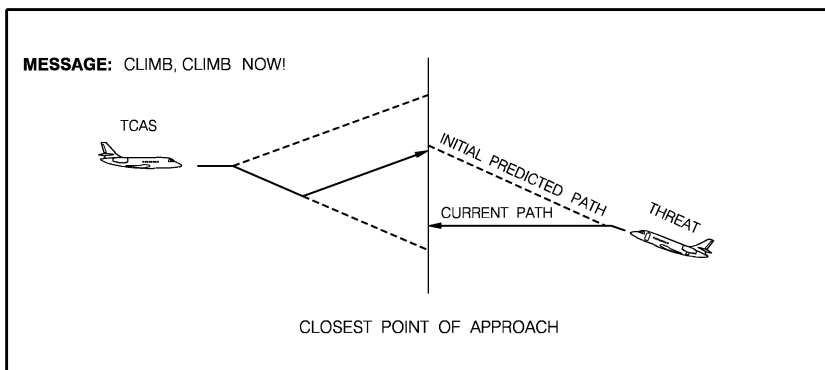
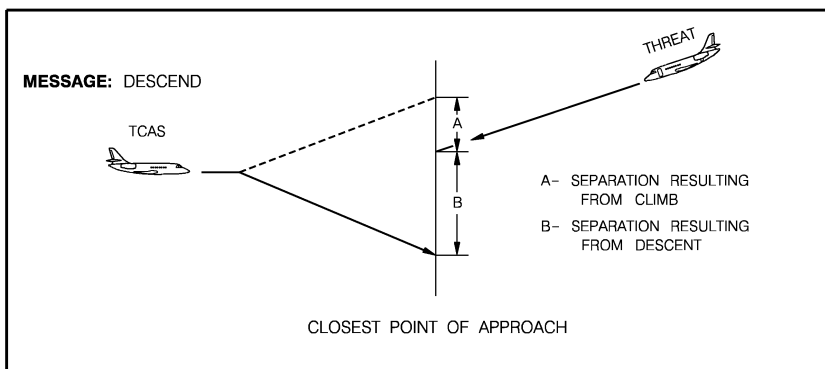

TCAS SITUATIONS

TCAS VOICE MESSAGES

NOTE: For airplanes Post-Mod. SB 145-34-0046 and Post-Mod. SB 145-31-0028, or with an equivalent modification factory incorporated, the Master Warning and Master Caution lights illumination associated to a TA/RA are not presented.

TYPE	MESSAGE	MEANING	REMARKS
TA	TRAFFIC, TRAFFIC	An intruder is expected to enter the collision area in 35 to 45 seconds. An indication of it has just been displayed on the MFD.	- For TCAS II, see NOTE 1. - For TCAS 7, all TA are inhibited below 500 ft AGL.
PREVENTIVE RA	MONITOR VERTICAL SPEED	Vertical speed is changing to a non-recommended value.	
	ADJUST VERTICAL SPEED, ADJUST	Vertical speed has to be adjusted to the recommended value indicated on the VSI.	TCAS 7 only.
	MAINTAIN VERTICAL SPEED, MAINTAIN	Maintain the vertical speed indicated on the VSI.	TCAS 7 only.
	MAINTAIN VERTICAL SPEED, CROSSING MAINTAIN	Maintain the vertical speed indicated on the VSI. During climb or descent, airplane will cross intruder's flight level.	TCAS 7 only.
CORRECTIVE RA	CLIMB	Climb at the vertical speed indicated on the VSI to clear the possible conflict.	
	DESCEND	Descend at the vertical speed indicated on the VSI to clear the possible conflict. Vertical Speed will be 1500 ft/min or greater.	See NOTE 1.
	REDUCE CLIMB	Reduce climb speed to clear the possible conflict.	Not valid for TCAS 7.
	REDUCE DESCENT	Reduce descent speed to clear the possible conflict.	- See NOTE 1 - Not valid for TCAS 7.
	CLIMB, CROSSING CLIMB	Climb at the indicated vertical speed on the VSI to clear possible conflict. During climb, airplane will cross intruder's flight level.	

(Continued)

TYPE	MESSAGE	MEANING	REMARKS
CORRECTIVE RA	DESCEND, CROSSING DESCEND	Descend at the indicated vertical speed on the VSI to clear possible conflict. During descend, airplane will cross intruder's flight level.	See NOTE 1.
	INCREASE CLIMB	Climb speed has to be increased to the recommended value to clear the possible conflict.	Vertical Speed must be 2500 ft/min or greater.
	INCREASE DESCENT	Descent speed has to be increased to the recommended value to clear the possible conflict. Vertical Speed must be 2500 ft/min or greater.	- For TCAS II, this message is inhibited below 1450 ft AGL. - For TCAS 7, this message is inhibited below 1450 ft AGL while descending and below 1650 ft AGL while climbing.
	CLIMB, CLIMB NOW!	After a descent advisory, TCAS detected a changing situation that requires the need to climb.	
	DESCEND, DESCEND NOW!	After a climb advisory, TCAS detected a changing in situation that requires the need to descend.	See NOTE 1.
	CLEAR OF CONFLICT	The possible conflict has been cleared. Message is presented only if intruder's transponder signal is valid.	Not presented if the intruder track or altitude information is lost.

- NOTE:**
- 1) Inhibited below 1000 ft AGL while descending and below 1200 ft AGL while climbing.
 - 2) All RAs are inhibited below 400 ft AGL while descending and below 600 ft AGL while climbing.
 - 3) For TCAS II, RA messages are repeated three times (one-word messages) and twice (two-word messages). For TCAS 7, all RAs are repeated twice.
 - 4) TA message sounds once.

CONTROLS AND INDICATORS

RMU RADIO PAGE - ATC/TCAS WINDOW

Refer to Navigation and Communication for further details on RMU controls.

Refer to RMU ATC/TCAS Control Page in this Section for further details on TCAS controls.

1 - TRANSPONDER OPERATING MODE

- Allows selection of TCAS modes:
 - TA ONLY - TCAS traffic advisory mode is selected.
 - TA/RA - TCAS traffic advisory and resolution advisory modes are selected.
- Refer to Section 2-18 - Navigation and Communication for further details.

2 - TCAS CONTROL SIDE IDENTIFICATION

- Indicates which TCAS display (MFD 1 or 2) is being controlled through that RMU. The selection of TCAS DSPY 1 or 2 is accomplished through the cross-side transfer button when the yellow cursor box is placed on this field.
- Color: white for on-side TCAS display and magenta for cross-side.

3 - TCAS RANGE DISPLAY

- Displays the selected TCAS range value.
- Color: green
- Possible selections are 6, 12, 20, 40 NM. Airplanes equipped with TCAS 7 also allow 80 and 100 NM selection.

4 - TCAS ALTITUDE BAND INDICATION

- Indicates the TCAS altitude band according to selected TCAS mode.
 - NORMAL (green) - With the TA display set to AUTO the operational TCAS altitude band will be from 1200 ft below to 1200 ft above the airplane. With the TA display set to MANUAL the operational TCAS altitude band will be from 2700 ft below to 2700 ft above the airplane.
 - ABOVE - The operational TCAS altitude band will be -2700 ft to +7000 ft.
 - BELOW - The operational TCAS altitude band will be -7000 ft to +2700 ft.

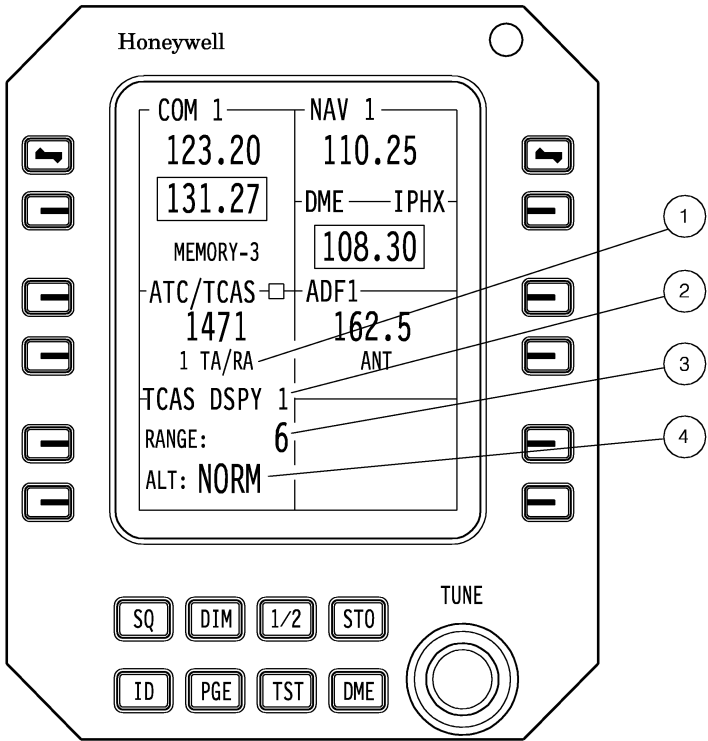

RMU RADIO PAGE

RMU ATC/TCAS CONTROL PAGE

1 - INTRUDER ALTITUDE

REL (green) - Intruder's altitude is displayed as a relative altitude to the airplane. Value is preceded by a plus or a minus signal, depending on whether the intruder is above or below the airplane.

FL (cyan) - Intruder's altitude is displayed as its flight level. This selection automatically reverts to REL after 20 seconds.

2 - TA DISPLAY

AUTO - Traffic is displayed only when a TA or RA condition exists.

MANUAL - All traffic detected by the system is displayed.

3 - FLIGHT LEVEL 1/2

- Displays the transponder-encoded altitude and the air data source.

Refer to transponder description (Section 2-18 – Navigation and Communication).

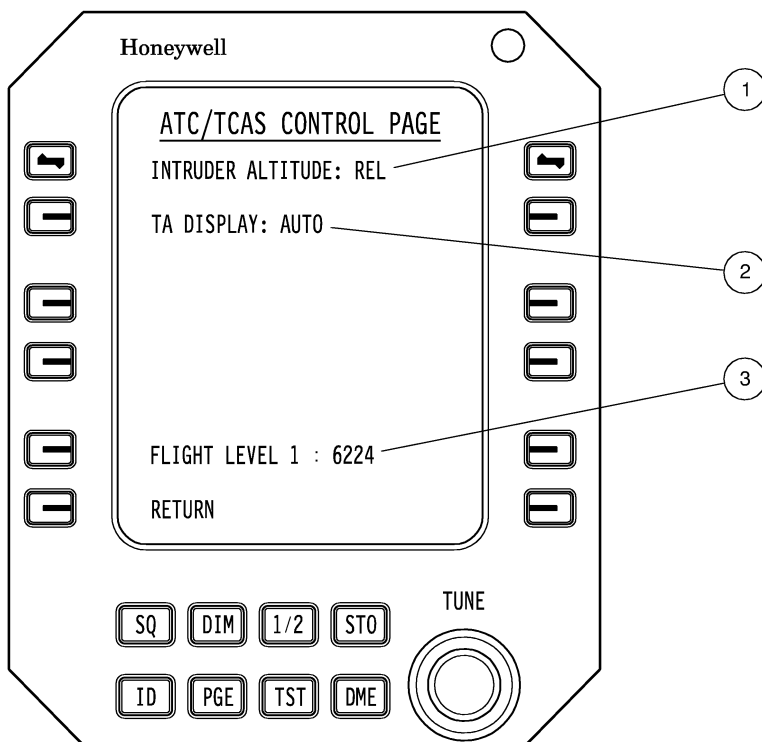

RMU ATC/TCAS CONTROL PAGE

TCAS TEST

The TCAS self-test is activated through the RMU TST button and may be performed on the ground or in flight. TCAS will operate normally if not tested.

To test the system proceed as follows:

- On the RMU radio page, set the ATC/TCAS window to the TA/RA mode. On the MFD, set TCAS mode.
- Press and hold for 7 seconds the RMU TST button.
- A white TCAS TEST message will be presented on the MFDs and PFDs.
- A TCAS TEST aural warning will sound.
- The Master Warning lights will flash.

NOTE: Some airplanes will not have the Master Warning light flashing during the test.

- The MFDs show a traffic test pattern, which permits the checking of each of the existing intruder symbols, i.e., a hollow blue diamond, a solid blue diamond, a solid amber circle and a solid red square.
- On the PFDs, the VSI shows red and green arc zones.
- At the end of the test, the RMU shows a green TCAS PASS message and a TCAS TEST PASS aural warning will sound.

MULTI FUNCTION DISPLAY

1 - INNER RANGE RING

- Displayed around airplane symbol to indicate a 2 NM range.
- Removed if outer range indicates distance above 20 NM.

2 - OUTER RANGE RING

- May be selected up to 40 NM. Airplanes equipped with TCAS 7 allow selection up to 100 NM.

3 - NO BEARING ADVISORIES INDICATION

- Indicates data related to a detected intruder, whose bearing cannot be determined.
- Up to two lines may be displayed indicating the kind of advisory, its distance, relative altitude and whether it is climbing or descending in excess of 500 ft/min.
- Colors: No bearings RAs: red.
No bearings TAs: amber.

4 - PROXIMATE TRAFFIC INDICATION

- Indicated by a solid cyan diamond.
- Represents any airplane within 6.5 NM horizontally and 1200 ft vertically, but whose path is not predicted to penetrate the Collision Area.

5 - INTRUDER'S VERTICAL MOVEMENT

- Indicated by an arrow next to the symbol that indicates if the intruder is climbing or descending in excess of 500 ft.
- Color: Same as of the associated symbol.

6 - INTRUDER'S ALTITUDE

- Indicated by a solid two-digit number below or above the intruder's symbol.
- Color: Same as of the associated symbol.
- Normal presentation is relative altitude, which displays the intruder's relative altitude in hundreds of feet. A plus or minus signal indicates if the intruder is above (+) or below (–) the airplane.
- Two question marks ("??") are displayed if the intruder's relative altitude is greater than 9900 ft, below or above.
- If intruder is below the airplane, intruder's altitude is displayed below its symbol.
- If intruder is above the airplane, intruder's altitude is displayed above its symbol.

7 - RESOLUTION ADVISORY INDICATION

- Indicated by a solid red square.

8 - TRAFFIC ADVISORY INDICATION

- Indicated by a solid amber circle.

9 - OTHER TRANSPONDER REPLYING TRAFFIC INDICATION

- Indicated by a hollow cyan diamond.
- Indicates other airplanes equipped with transponder within the specified range and 2700 ft of vertical separation.
- Not displayed if a TA or RA is in process.

10 - OUT OF RANGE INTRUDER

- Indicates detected intruders that are out of display range.
- Indicated as half the associated symbol.

11 - INTRUDER'S ALTITUDE MODE INDICATION

- Indicates whether the selected intruder's altitude is relative or flight level.

12 - TCAS BAND SELECTED

- Indicates whether the selected band for TCAS is below or above.

13 - TCAS MODE ANNUNCIATIONS

- Indicates current TCAS mode.
- Colors and labels are as follows, in the order of priority:
 - TCAS TEST - white
 - TCAS OFF - white
 - TCAS FAIL - amber
 - TA ONLY - white
 - TCAS - white
 - TCAS AUTO - white

PRIMARY FLIGHT DISPLAY

For further information on Vertical Speed Indicator, refer to Section 2-17 – Flight Instruments.

VSI

- Indicates the recommended vertical speed to avoid a possible conflict.
- Green range - displayed along the scale, indicates the range of vertical speeds to be attained to avoid a conflict situation.
- Red range - displayed along the scale, indicates the range of vertical speeds prohibited for the current situation.
- Green range may be displayed together with the red range or split in two parts, depending on situation.
- Red range may be displayed alone, together with the green range, or split in two parts, depending on the situation.

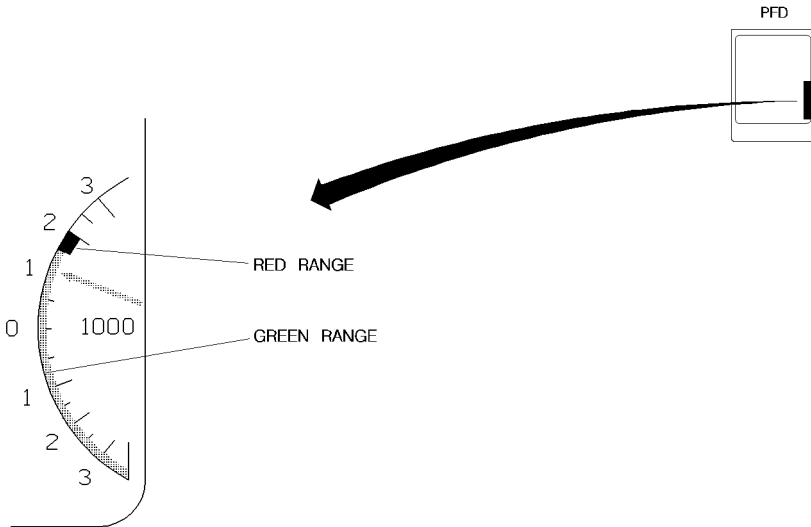

PRIMARY FLIGHT DISPLAY