



**AUXILIARY POWER UNIT
Table of Contents**

Vol. 1

04-00-1

REV 3, May 03/05

CHAPTER 4 – AUXILIARY POWER UNIT

	Page
TABLE OF CONTENTS	04-00
Table of Contents	04-00-1
INTRODUCTION	04-10
Introduction	04-10-1
APU POWER PLANT	04-20
APU Power Plant	04-20-1
Engine	04-20-1
Gearbox	04-20-1
SYSTEMS	04-30
Systems	04-30-1
Lubrication	04-30-1
Fuel	04-30-1
Ignition and Starting	04-30-1
Air Intake and Exhaust	04-30-1
CONTROL	04-40
Controls	04-40-1
Starting	04-40-1
Stopping	04-40-1
Protective Shutdown	04-40-6
System Circuit Breakers	04-40-7

LIST OF ILLUSTRATIONS

INTRODUCTION		
Figure 04-10-1	Auxiliary Power Unit - Introduction	04-10-2
Figure 04-10-2	APU Altitude and Airspeed Envelope	04-10-3
Figure 04-10-3	Pneumatic Flow	04-10-4
Figure 04-10-4	APU Start and Operating Limits	04-10-5
Figure 04-10-5	APU Door Position	04-10-6
Figure 04-10-6	EGT Shutdown Schedule	04-10-7
SYSTEMS		
Figure 04-30-1	APU Controls and ECU Interface	04-30-2



**AUXILIARY POWER UNIT
Table of Contents**

Vol. 1

04-00-2

REV 3, May 03/05

CONTROL

Figure 04-40-1	Auxiliary Power Unit - Control	04-40-2
Figure 04-40-2	EICAS Auxiliary Power Unit Indications - Primary	04-40-3
Figure 04-40-3	Auxiliary Power Unit and Indications - Status	04-40-4
Figure 04-40-4	APU Start Sequence	04-40-5

	AUXILIARY POWER UNIT Introduction	Vol. 1	04-10-1
		REV 3, May 03/05	

1. **INTRODUCTION**

The auxiliary power unit (APU) is a gas turbine power plant which drives an electrical generator. The generator is rated at 40 kVA and produces 115 VAC electrical power for backup to the main engine generators (refer to Chapter 7). The APU also supplies compressed air to the pneumatic system for main engine starting and environmental control (refer to Chapter 19). To prevent compressor surge, some compressor air is vented overboard by a surge control valve.

The APU is enclosed within a fireproof tailcone assembly. The APU compartment is composed of an upper section and forward and aft bulkheads made of titanium. Two clamshell doors made of fireproof composite material enclose the sides and bottom of the compartment.

An Electronic Control Unit (ECU), located in the aft equipment bay, controls the APU through all phases of operation. The ECU monitors all sensors and switches, sets up the appropriate fuel acceleration schedules and relays specific operating data to the engine indication and crew alerting system (EICAS). The ECU is powered through selection of a PWR/FUEL switchlight on the APU control panel in the flight compartment.

The APU intake door position is continuously shown on the EICAS status page. The APU RPM and exhaust gas temperature (EGT) are shown on the EICAS status page, only when the APU PWR/FUEL switchlight on the APU control panel is selected.

	Flight Crew Operating Manual CSP C-013-067	
--	---	--

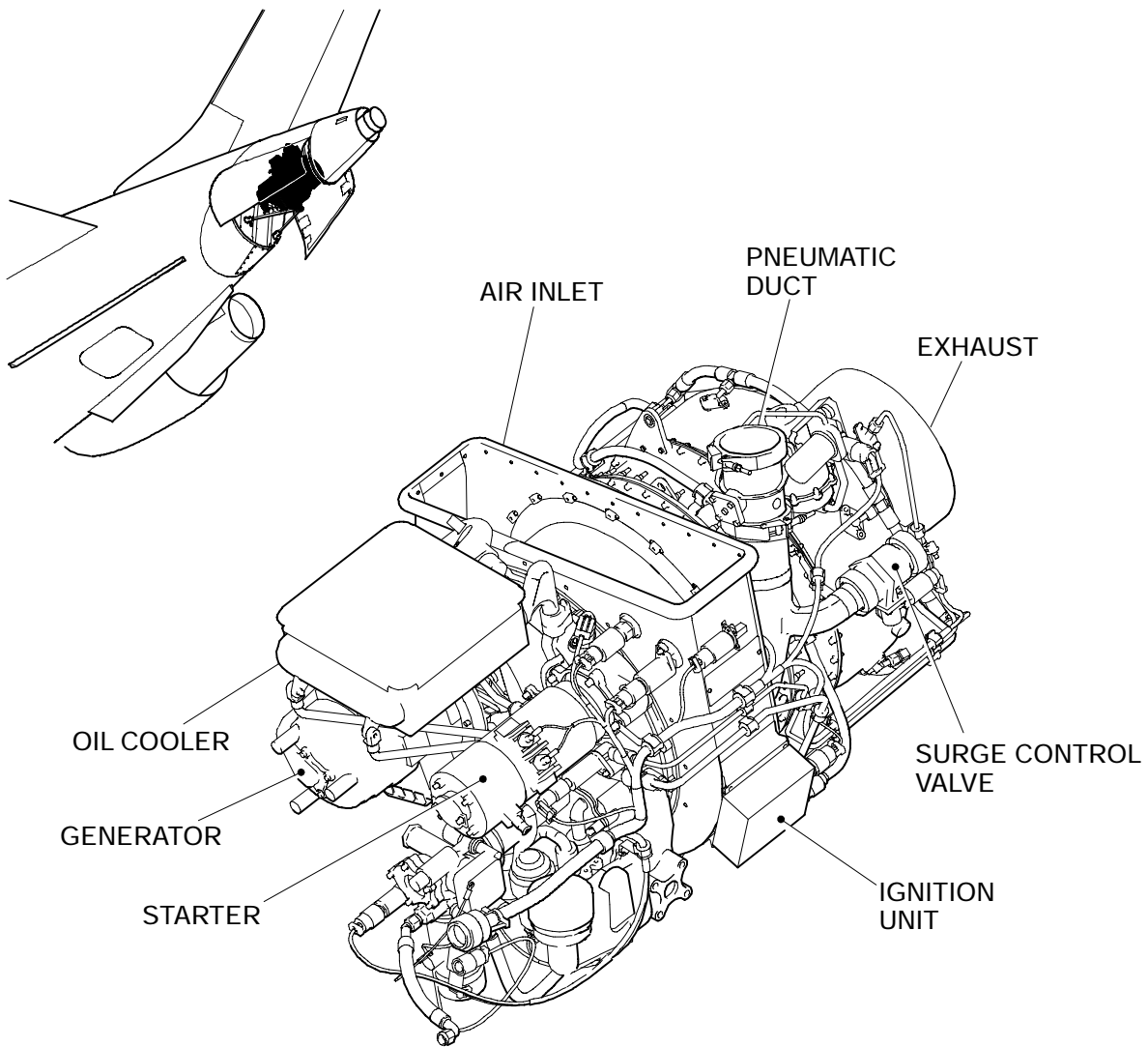

Auxiliary Power Unit – Introduction
Figure 04-10-1

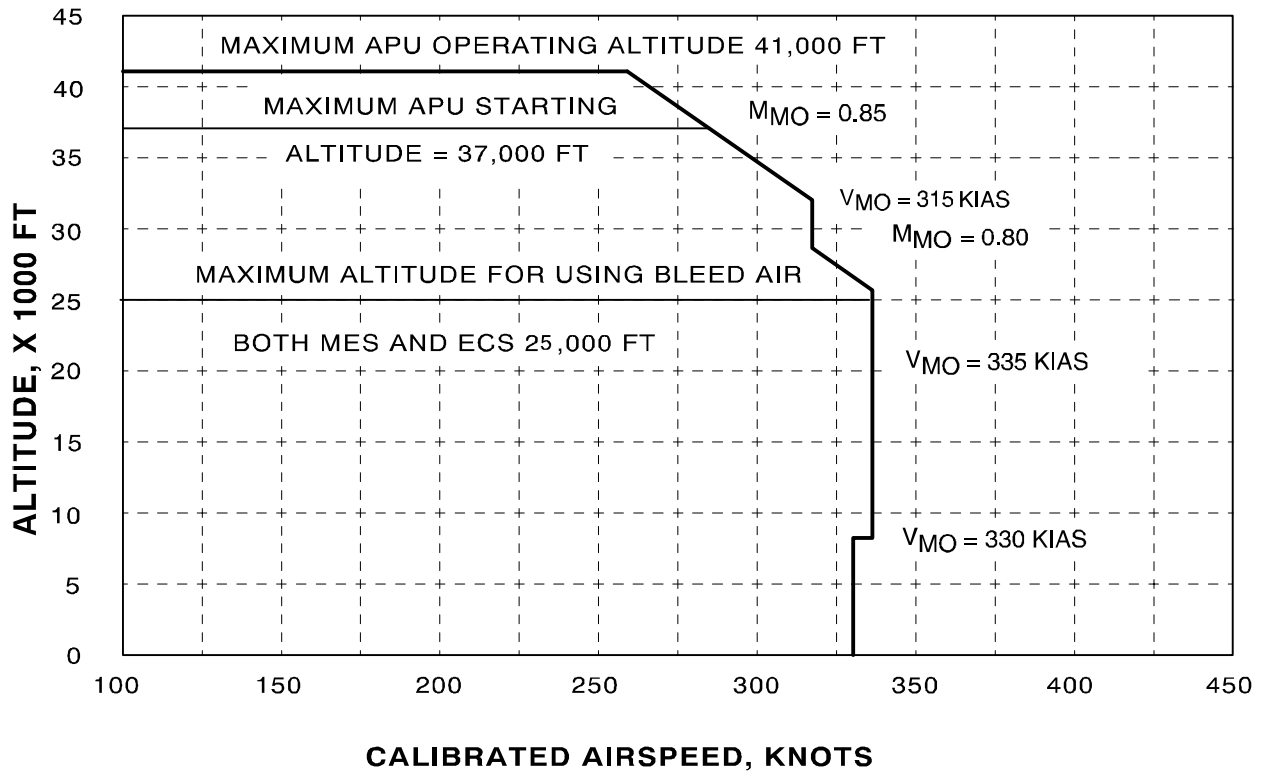

APU Altitude and Airspeed Envelope
Figure 04-10-2

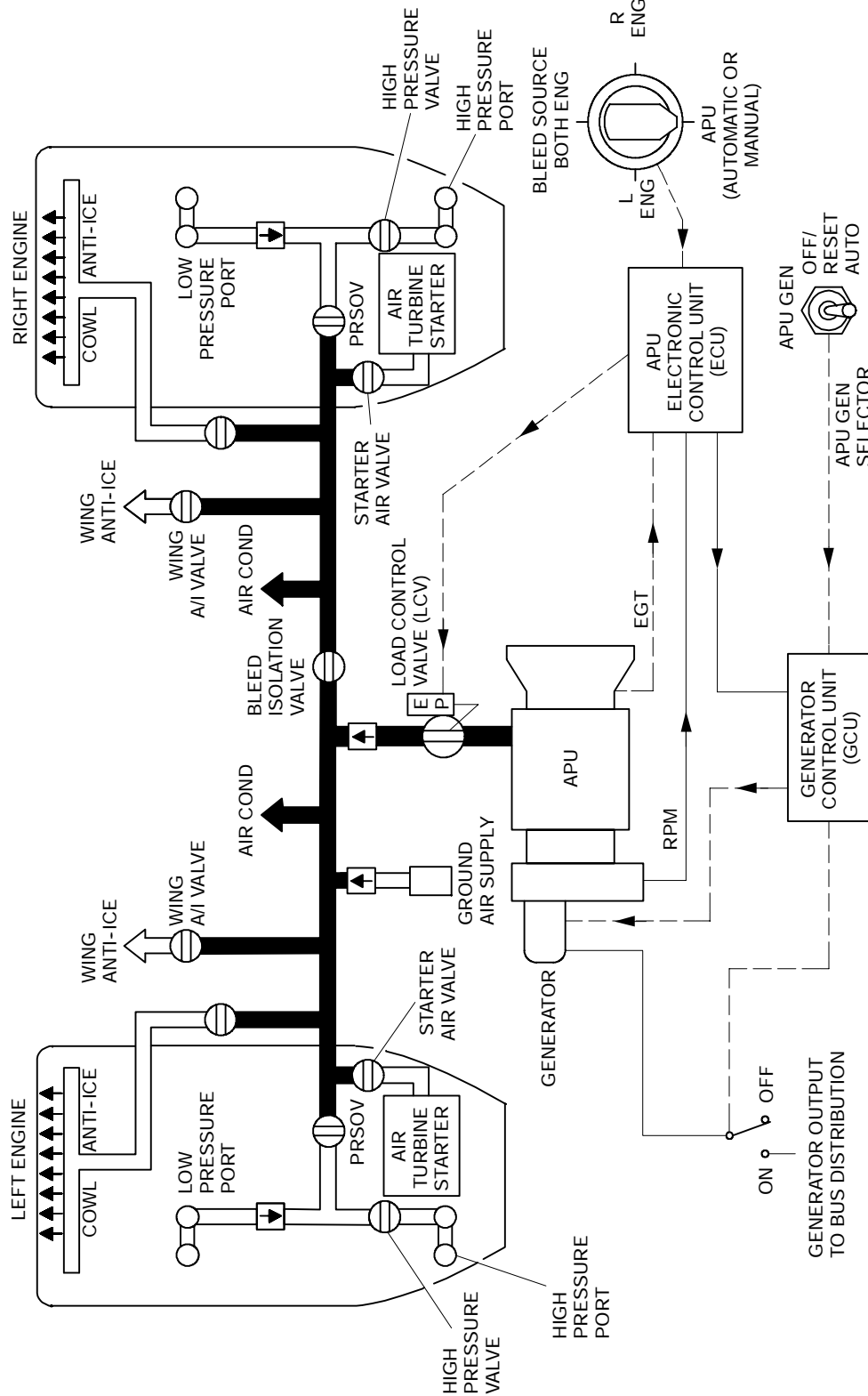

Pneumatic Flow
Figure 04-10-3

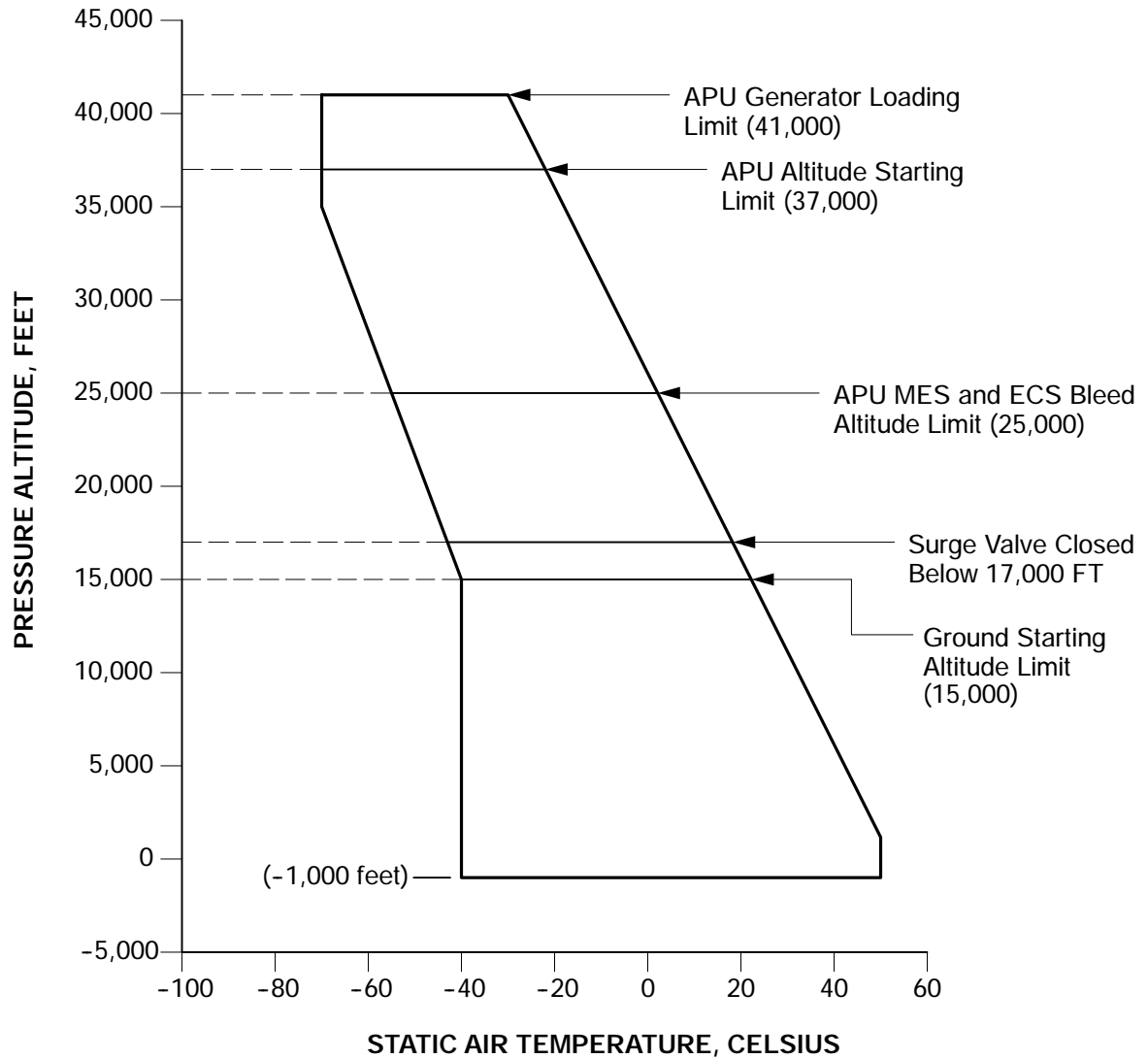

APU Start and Operating Limits
Figure 04-10-4

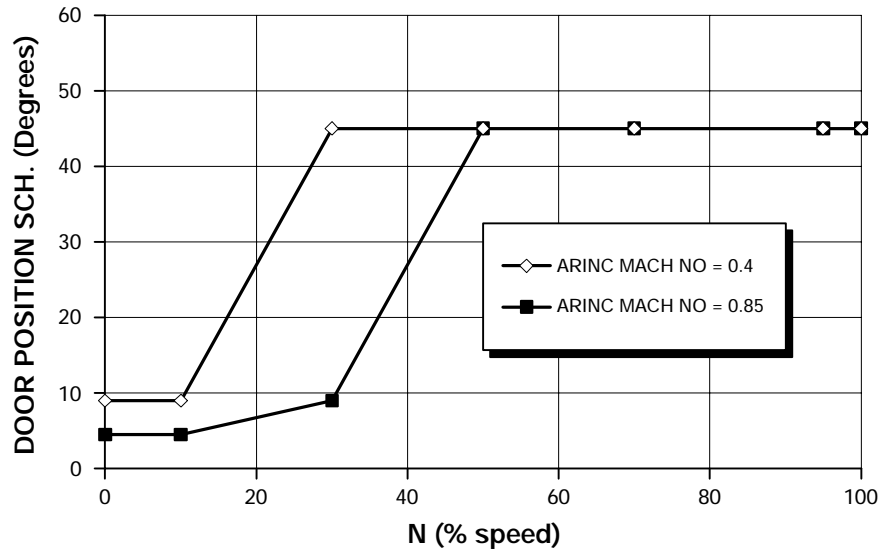

N (% speed)	ARINC MACH NO = 0.4 DOOR POSITION SCH. (Degrees)	ARINC MACH NO = 0.85 DOOR POSITION SCH. (Degrees)
0	9.0	4.5
10	9.0	4.5
30	45.0	9.0
50	45.0	45.0
70	45.0	45.0
95	45.0	45.0
100	45.0	45.0

APU DOOR POSITION SCHEDULE

APU Door Position
Figure 04-10-5

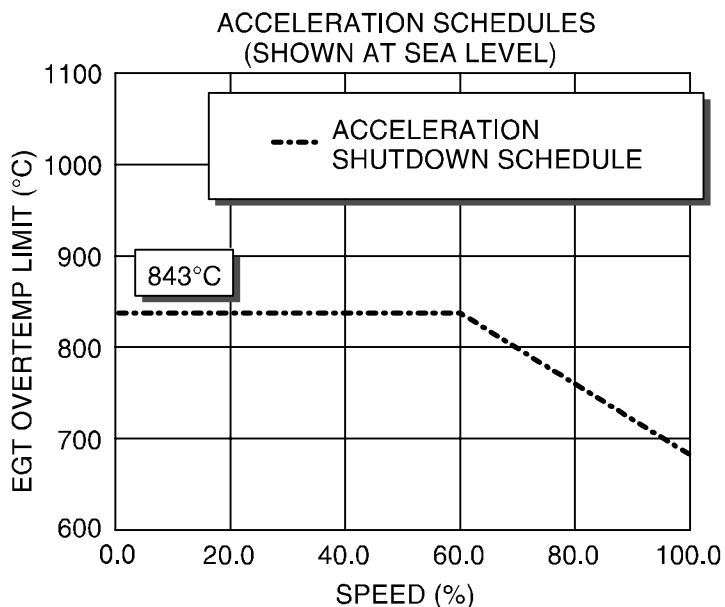

NOTE

EGT acceleration shutdown limit increases with higher altitudes.

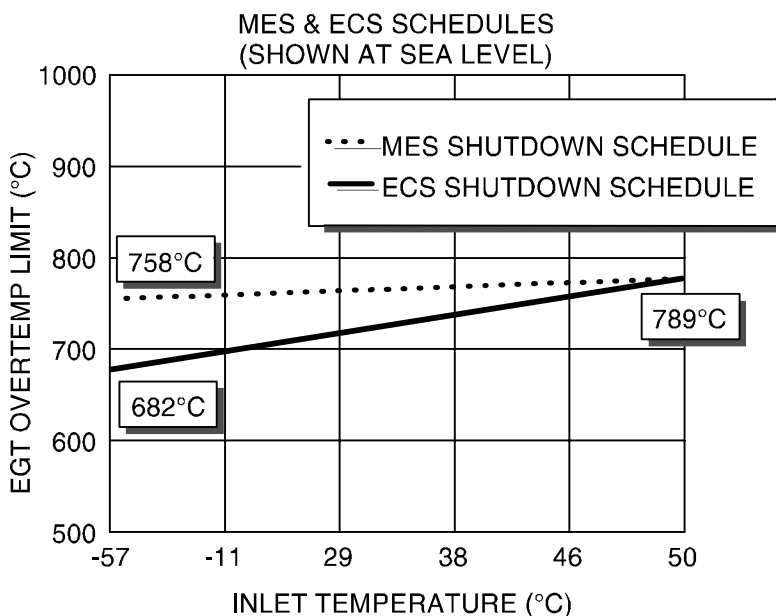

NOTE

EGT ECS & MES shutdown limits increase with higher inlet temperatures and higher altitudes.

EGT Shutdown Schedule
Figure 04-10-6



**AUXILIARY POWER UNIT
Introduction**

Vol. 1

04-10-8

REV 3, May 03/05

THIS PAGE INTENTIONALLY LEFT BLANK

	AUXILIARY POWER UNIT Power Plant	Vol. 1	04-20-1
		Sep 09/02	

1. APU POWER PLANT

The APU power plant consists of a gas turbine engine and gearbox.

A. Engine

The engine is a single-shaft, constant speed design, consisting of a compressor, a combustor and a two-stage turbine. The compressor draws large volumes of air through the inlet ducting and delivers it under pressure to the combustor. Fuel from the left collector tank is added to the high pressure air and ignited, increasing the energy of the airflow. The high velocity, high temperature gasses are delivered to the turbine section. The turbine converts the high velocity gasses into mechanical energy to drive the compressor and gearbox.

B. Gearbox

The gearbox reduces the turbine shaft rpm to a speed suitable to operate the gearbox mounted accessories. Accessories include the lubrication module, fuel control unit, electric starter and generator. The gearbox has an integral oil sump. The oil level can be checked using a sight glass on the oil filler assembly.



**AUXILIARY POWER UNIT
Power Plant**

Vol. 1

04-20-2

Sep 09/02

THIS PAGE INTENTIONALLY LEFT BLANK

	AUXILIARY POWER UNIT Systems	Vol. 1	04-30-1
		REV 3, May 03/05	

1. **SYSTEMS**

The APU consists of a lubrication system, fuel system, ignition and starting systems, and an air intake and exhaust.

A. **Lubrication**

The lubricating system consists of a mechanically driven lubrication module, oil filter, oil cooler, low oil pressure switch, oil temperature sensor and a deprime solenoid. The lube module provides pressurized oil to the power plant, gearbox and generator for lubrication and heat removal. To ease starting under cold conditions, a de-prime solenoid allows vent air to enter the lube pump to reduce starter motor drag.

B. **Fuel**

Fuel is supplied to a fuel control unit from the left collector tank by a dedicated APU fuel pump (refer to Chapter 13). The fuel control unit starts, stops and modulates the flow of fuel to the APU in response to commands from the ECU.

C. **Ignition and Starting**

The ignition and starter systems are controlled by the ECU. The ECU commands the DC starter motor to rotate the power plant. The starter accelerates the power plant to a specific speed where the ECU introduces fuel to the combustor. The ignition system is used to ignite the fuel/air mixture in the combustor which further accelerates the power plant. As the APU accelerates toward the onspeed condition, the starter is disengaged. When the APU reaches normal operating speed, the ignition is turned off. At this point the engine becomes self sustaining.

D. **Air Intake and Exhaust**

The air inlet door is located in the upper right side of the rear fuselage and is controlled by the ECU. When open, the door provides ram air for APU operation and oil cooling. On the ground, the air inlet door has only two positions, closed or open (0 and 45 degrees). In flight, during APU start, the ECU limits the door position in response to APU engine rpm and aircraft speed. This prevents excessive amounts of ram air which could cause the APU to flameout. When the APU is not operating, the door remains closed to prevent windmilling of the compressor. The inlet door also serves as a barrier in the event of fire. The exhaust duct is composed of stainless steel and is centered in the tailcone.

	Flight Crew Operating Manual CSP C-013-067	
--	---	--

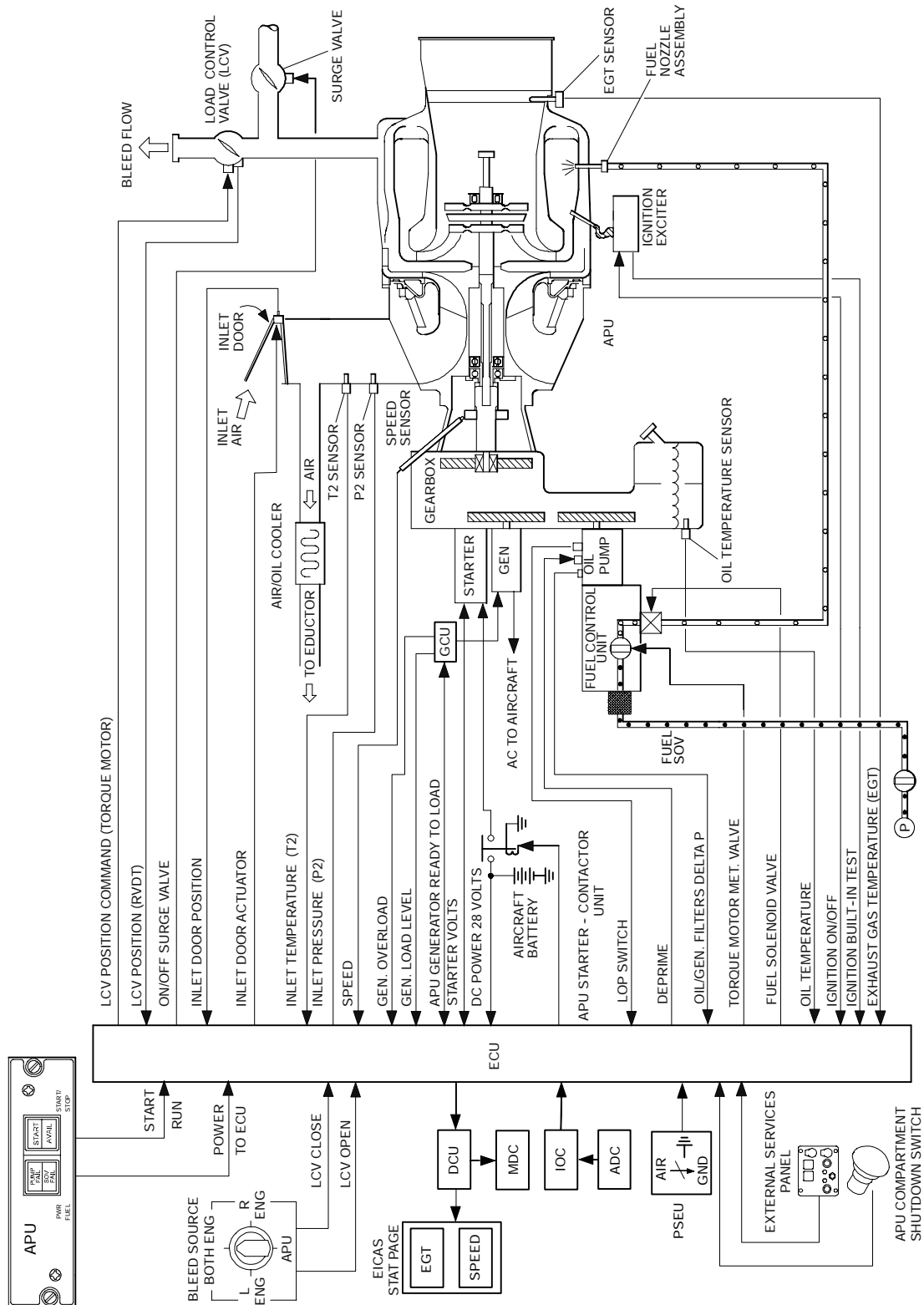

APU Controls and ECU Interface
Figure 04-30-1

	AUXILIARY POWER UNIT Control	Vol. 1	04-40-1
		REV 1, Jan 13/03	

1. **CONTROL**

The APU electronic control unit (ECU) provides full automatic control of APU starting, stopping, and protects the APU during all modes of operation. The control system ensures that priority is given to electrical loads by reducing bleed airflow.

A. **Starting**

When the PWR FUEL switchlight, on the APU panel, is selected:

- The ECU is powered
- The air inlet door opens (position is displayed on the EICAS status page)
- The APU RPM and EGT gauges are displayed on the EICAS status page
- The fuel pump comes on

When the START/STOP switchlight, on the APU control panel, is selected:

- The ignition is activated
- The starter motor is energized
- The fuel shutoff valve opens
- The START legend on the APU panel comes on
- The APU START status message is displayed

The starter motor is deactivated at 46% rpm on the ground or at 60% rpm if in flight and the START legend goes out. When the APU reaches 95% rpm, ignition is turned off. Two seconds after the APU reaches 99% rpm, the AVAIL legend, in the START/STOP switchlight, illuminates to notify the crew that the APU is ready for loading.

B. **Stopping**

To shutdown the APU, the crew pushes the START/STOP switchlight on the APU panel. The APU will automatically shed its loading and shutdown. The PWR/FUEL switch is deselected to close the fuel shutoff valve and to remove primary electrical power to the ECU.

In the event of an emergency, the flight crew can press the APU FIRE PUSH switchlight on the glareshield. On the ground, the APU can be shut down by pushing an APU emergency stop button located in the APU compartment or by selecting an APU shut-off switch on the external services panel on the RH forward fuselage. Either selection sends a signal to the ECU to carry out an immediate shutdown.

	Flight Crew Operating Manual CSP C-013-067	
--	---	--

PWR FUEL

When pressed, APU fuel pump is energized and APU fuel shut-off valve opens, APU EICAS gauges and APU IN BITE message are displayed. On the ground, air inlet door is scheduled to open.

- PUMP FAIL (amber) light comes on to indicate that APU fuel pump has failed.
- SOV FAIL (amber) light comes on to indicate that the APU fuel shut-off valve has failed.

When pressed again, APU fuel pump is de-energized.

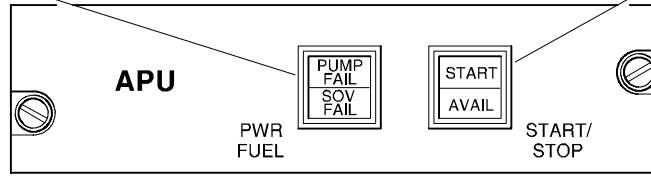

**APU Control Panel
Overhead Panel**

START/STOP

When pressed in:

- Start motor on
- START light (white) comes on
- At 60% rpm, START light goes out
- AVAIL light (green) comes on 2 seconds after APU reaches 99% rpm.

When pressed out:

- Fuel shut-off valve closes
- APU shuts down
- AVAIL light goes out
- Air inlet door closes

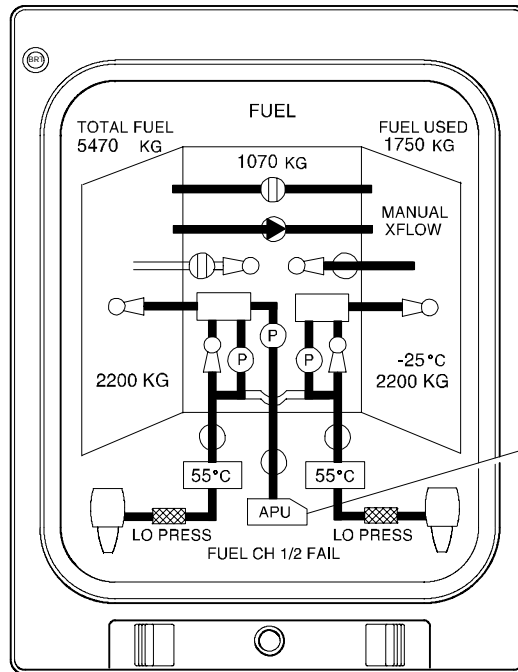

Fuel Page

APU Symbol

- White - APU not running
- Half-Intensity Cyan - APU ready to load
- Half-Intensity Magenta - Invalid data

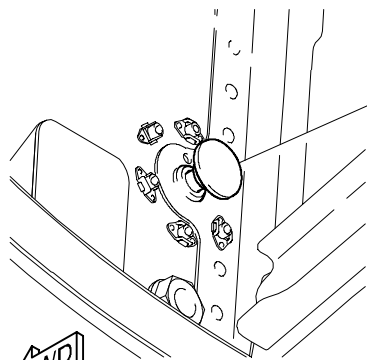

**APU Compartment
Forward Firewall**

APU Emergency Stop

Used by maintenance personnel to shut down the APU.

APU SHUT-OFF (Guarded)

Used by maintenance personnel to shut down the APU.

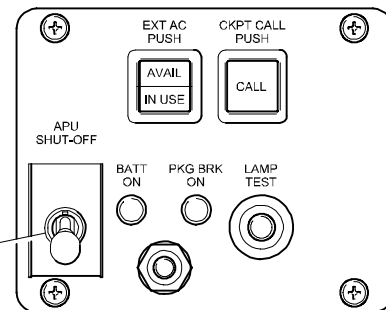

**External Service Panel
Right Forward Fuselage**

Auxiliary Power Unit – Control <1001, 1205>
Figure 04-40-1

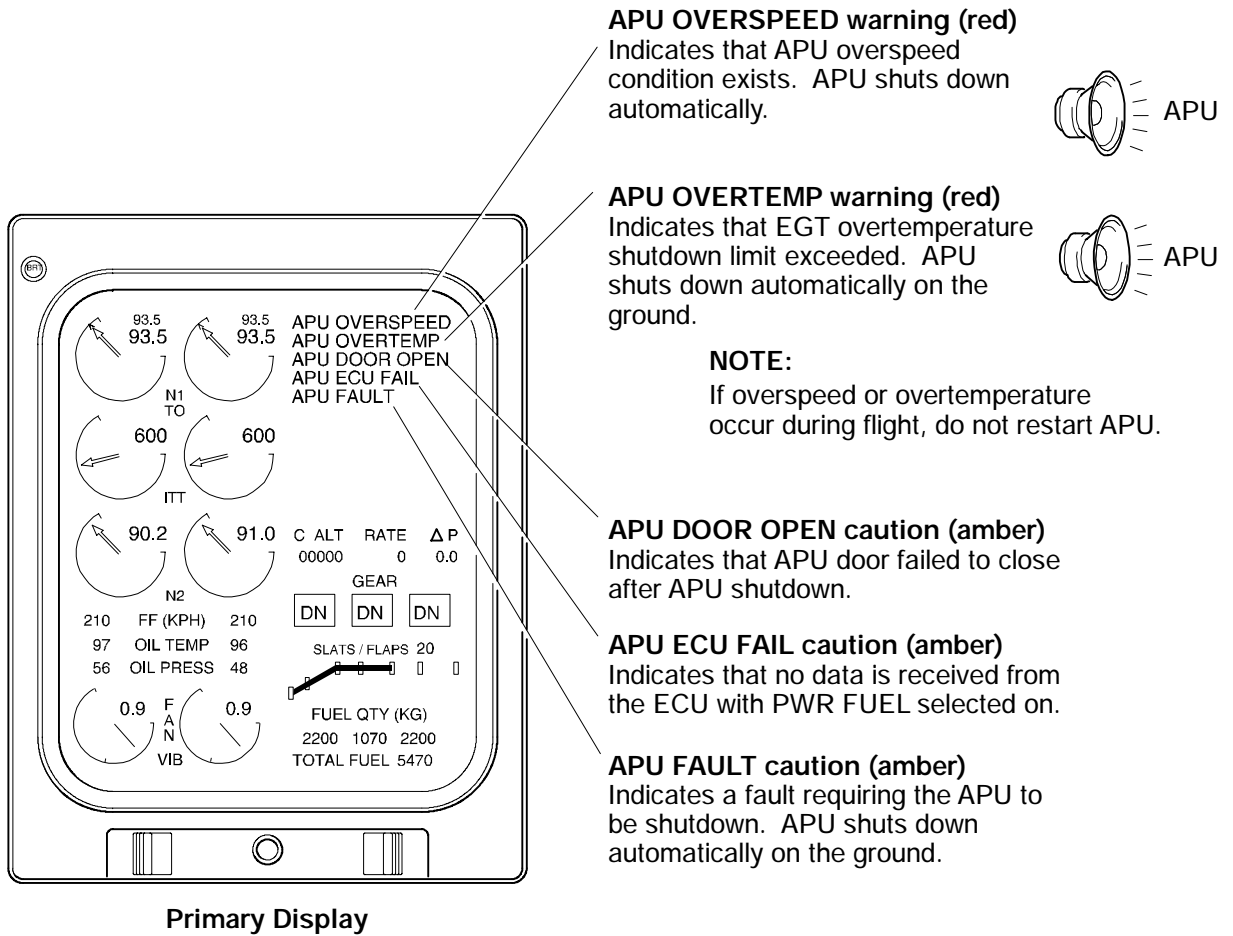

NOTE:
For pneumatic messages refer to Chapter 19.

EICAS Auxiliary Power Unit Indications – Primary Page <1001>
Figure 04-40-2

APU ALT LIMIT status (white)
Indicates that surge control valve has failed.

APU FAULT status (white)
Indicates loss of redundancy in sensors, impending filter bypass or fuel valve has failed open.

APU IN BITE status (white)
Indicates air inlet door not in position with PWR FUEL selected on.

APU START status (white)
Indicates that starter motor is engaged.

APU Inlet Door Status Indicator (white)
Indicates air inlet door position:
DOOR CLSD
DOOR OPEN
DOOR INHIB/CLSD
DOOR INHIB/OPEN
DOOR - - - (amber dashes)

NOTE:
Amber dashes indicates position unknown. Amber DOOR OPEN indicates door has failed to close after APU shutdown.

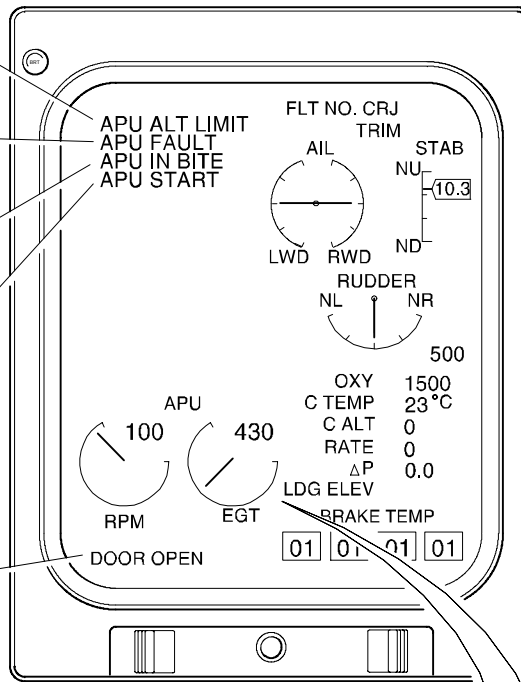

Status Page

APU

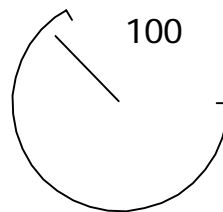

RPM

APU RPM Readout, scale and pointer (green)
Indicates percent of APU rpm. Readout and pointer turn red during overspeed condition.

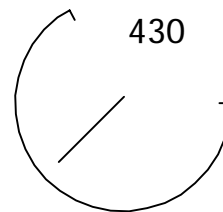

EGT

APU EGT Readout, scale and pointer (green)
Indicates exhaust gas temperature in degrees Centigrade. Readout and pointer turn red during overtemperature condition.

**Auxiliary Power Unit and Indications – Status
Figure 04-40-3**

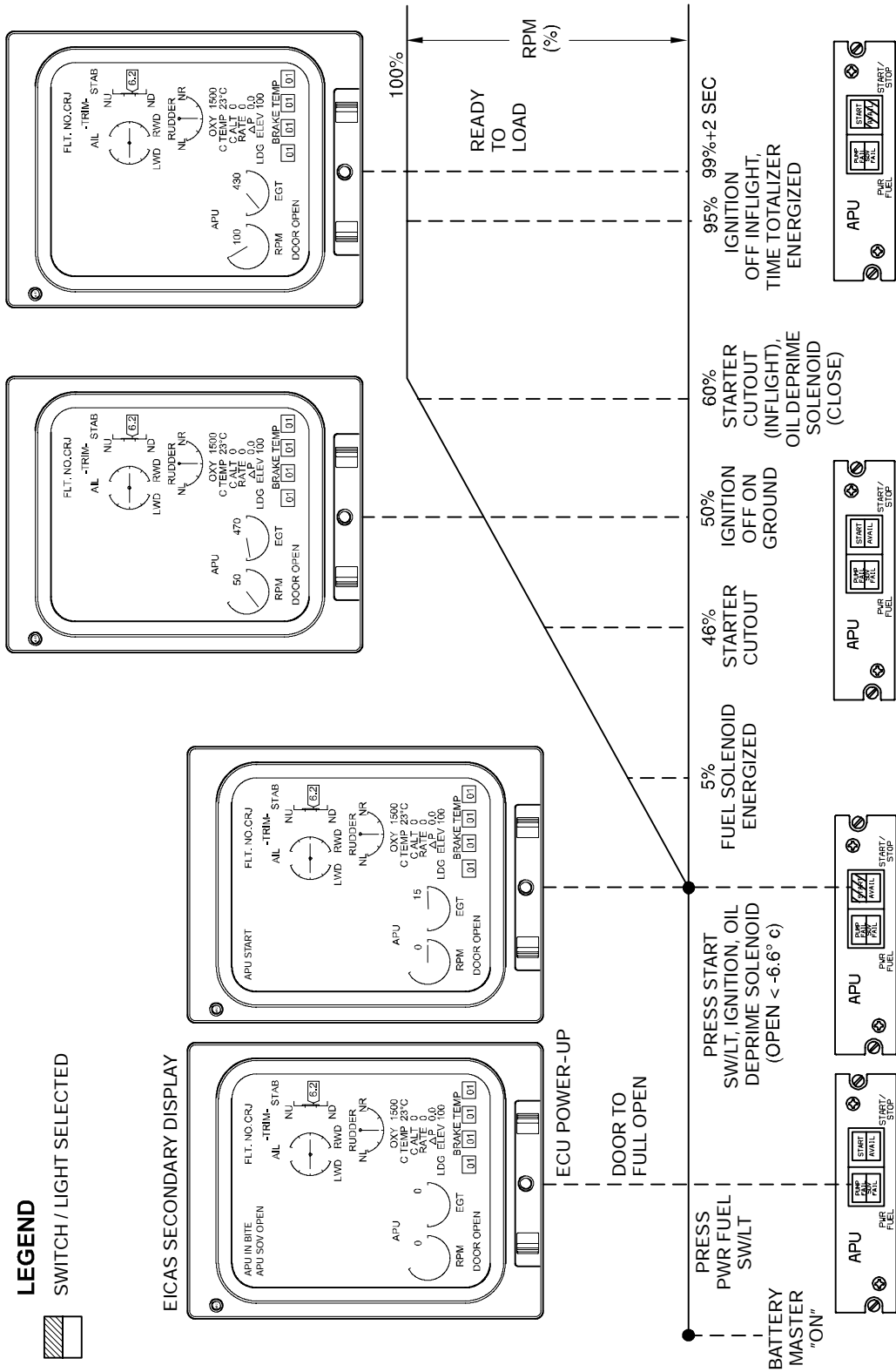

Auxiliary Power Unit Start Sequence
Figure 04-40-4



**AUXILIARY POWER UNIT
Control**

Vol. 1

04-40-6

Sep 09/02

C. Protective Shutdown

The ECU will shut down the APU (on ground or in flight) if any of the following faults occur:

- Overspeed - APU speed exceeded 106 percent.
- Loss of overspeed protection - A combination of speed sensors or overspeed circuits fail.
- Loss of speed sensor signals - Both speed sensor channels failed.
- APU door failed to open within 30 seconds of command.
- APU door was open then closed without command, while the APU was operating.
- ECU internal failure.
- No APU rotation - During start, speed did not reach 5% within specified time requirement (12 seconds for warm oil; 50 seconds for cold oil).
- No APU light-off - Light-off was not detected within specified time requirement.
- Slow start - Starting time period exceeded.
- No acceleration - Acceleration during start was less than 0.05% per second for 15 seconds.
- Speed fallback - The APU speed drops below 50% after starter cutout.
- Loss of DC power - Battery power lost for more than 200 milliseconds.
- APU fire/emergency - APU FIRE PUSH switch or one of the emergency shutdown switches was selected.
- Loss of air inlet door position sensor signal - Failure of air inlet door position sensor.

The ECU will shut down the APU (on ground) if any of the following faults occur:

- Overtemperature - APU EGT exceeded schedule limits.
- Low oil pressure (LOP) - Low oil pressure exists for 15 seconds with the APU operating.
- Oil pressure switch failed - Cannot detect a low oil pressure condition.
- High oil temperature - Oil temperature exceeded 300°F with the APU operating.
- Reverse flow - APU inlet temperature exceeded 350°F for 5 seconds with with the APU operating and LCV open.

	AUXILIARY POWER UNIT Control	Vol. 1	04-40-7
		Sep 09/02	

- Underspeed - APU was operating and speed dropped below 80% for 5 seconds.
- Loss of EGT sensors - Both EGT sensor channels failed.
- APU oil filter in an impending bypass condition.

D. System Circuit Breakers

SYSTEM	SUB-SYSTEM	CB NAME	BUS BAR	CB PANEL	CB LOCATION	NOTES
Auxiliary Power Unit	Control	APU CONT	BATTERY BUS	1	N7	
		APU ECU PRIM			N11	
		APU ECU SEC	APU BATT DIRECT BUS	5	A6	
		APU DOOR ACT			B1	



**AUXILIARY POWER UNIT
Control**

Vol. 1

04-40-8

Sep 09/02

THIS PAGE INTENTIONALLY LEFT BLANK