



SECTION I GENERAL DESCRIPTION

AIRCRAFT GENERAL DESCRIPTION

The Learjet Model 31A aircraft, manufactured by Learjet, Inc., are all metal, pressurized, low-wing, turbofan-powered monoplanes. The high-aspect ratio, fully cantilevered, swept-back wings with winglets are of conventional riveted construction except for the upper section of the winglets, which utilize full-depth honeycomb core bonded to the outer skin. The fuselage utilizes "area rule" design and is of semi-monocoque construction. Two inverted "V" ventral fins (delta fins) are fitted to the aft section of the tailcone to provide the aircraft with favorable stall recovery characteristics and additional lateral/directional stability. Thrust is provided by two pod-mounted TFE-731 turbofan engines manufactured by Garrett Division of Allied Signal. Each engine is provided with an independent fuel system with fuel storage provided in the wing and fuselage tanks. Engine-driven hydraulic pumps provide hydraulic power for braking, extending or retracting the landing gear, wing flaps, spoilers, and thrust reversers. Fully retractable tricycle-type landing gear with dual main gear wheels, anti-skid braking system, and nose-wheel steering is utilized. The ailerons, rudder, and elevator are manually controlled through cables, bellcranks, pulleys, and push-pull tubes. An electrically-actuated trim tab is installed on the left aileron and rudder to provide lateral and directional trim. Longitudinal trim is accomplished by changing the incidence of the horizontal stabilizer with an electrically-operated linear actuator. Aircraft air conditioning systems provide heating, cooling, and pressurization for the crew, passenger, and cabin baggage compartments.

COCKPIT DESCRIPTION

The instrument panel and pedestal are accessible and readable by either crew member. Circuit breaker panels are located on the cockpit sidewalls. In some aircraft flashlights are installed above the circuit breaker panels. In some aircraft a pencil holder is installed under the glareshield on both the pilot's and copilot's side. A magnetic compass is installed on the windshield center post. The side panels above the armrests contain the oxygen control valve (pilot's side), instrument light controls, oxygen masks, and smoke goggles. No switches (except dome light switches), instruments, or placards are located overhead. Map storage is provided in the aft portion of each armrest. The pilot's and copilot's seats (figure 1-8) are adjustable forward, aft, and vertically. A curtain or door, located behind the crew, may be closed for privacy or to darken the cockpit. A handheld fire extinguisher is readily accessible to the crew.

CABIN DESCRIPTION

The aircraft cabin is divided into two areas: the passenger area and the baggage compartment. Access to the baggage compartment, located in the aft cabin, is accomplished through the cabin. The cabin window adjacent to the wing leading edge on the right hand side of the cabin serves as an emergency exit. Individual reading lights, fresh-air eyeball outlets, and passenger oxygen masks are located in the overhead convenience panels above the seats.

Specific seating arrangements and passenger accommodations are selected by the owner and are not included in this manual.

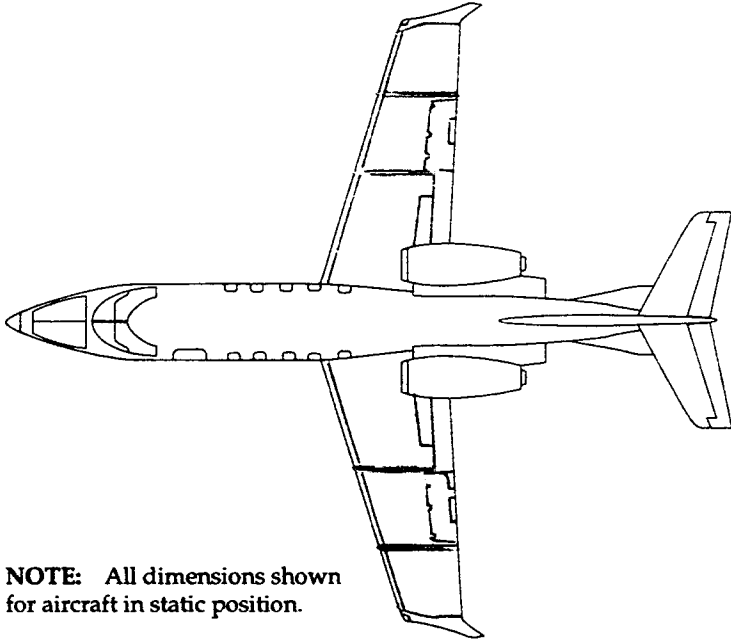

NOTE: All dimensions shown for aircraft in static position.

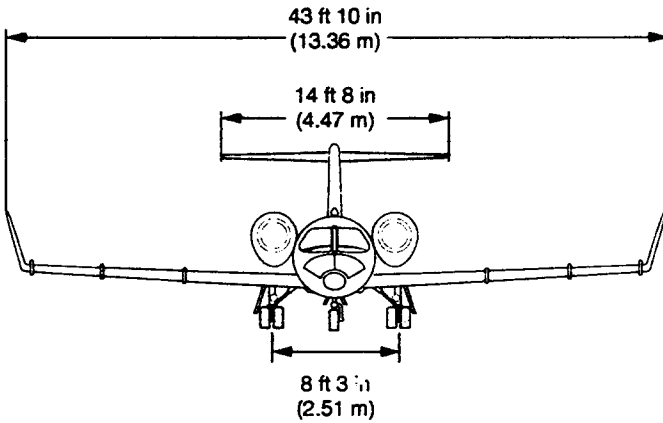
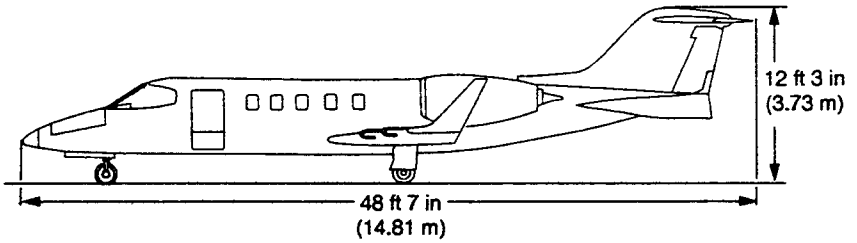

AIRPLANE THREE - VIEW
Figure 1-1

INTENTIONALLY LEFT BLANK

1. Avionics Compartment
2. Pitot-Static Tube
3. Stall Warning Vane
4. Lower Cabin Entry Door
5. Upper Cabin Entry Door
6. Inboard Wing Stall Fence
7. Leading Edge Triangles
8. Boundary Layer Energizers
9. Outboard Wing Stall Fence
10. Leading Edge Stall Fence
11. Wing Navigation Light
12. Winglet Strobe Light (*Aircraft 31-035 thru 31-173*)
13. Wing Filler Cap
14. Spoiler
15. Delta Fin
16. VHF Navigation Antenna
17. Rudder
18. Elevator
19. Tail Navigation and Strobe Light
20. Tail Anti-Collision Light
21. Recognition Light
22. Ram Air Inlet
23. Fuselage Fuel Cell
24. Flap
25. Aileron
26. Emergency Exit
27. Stall Strip

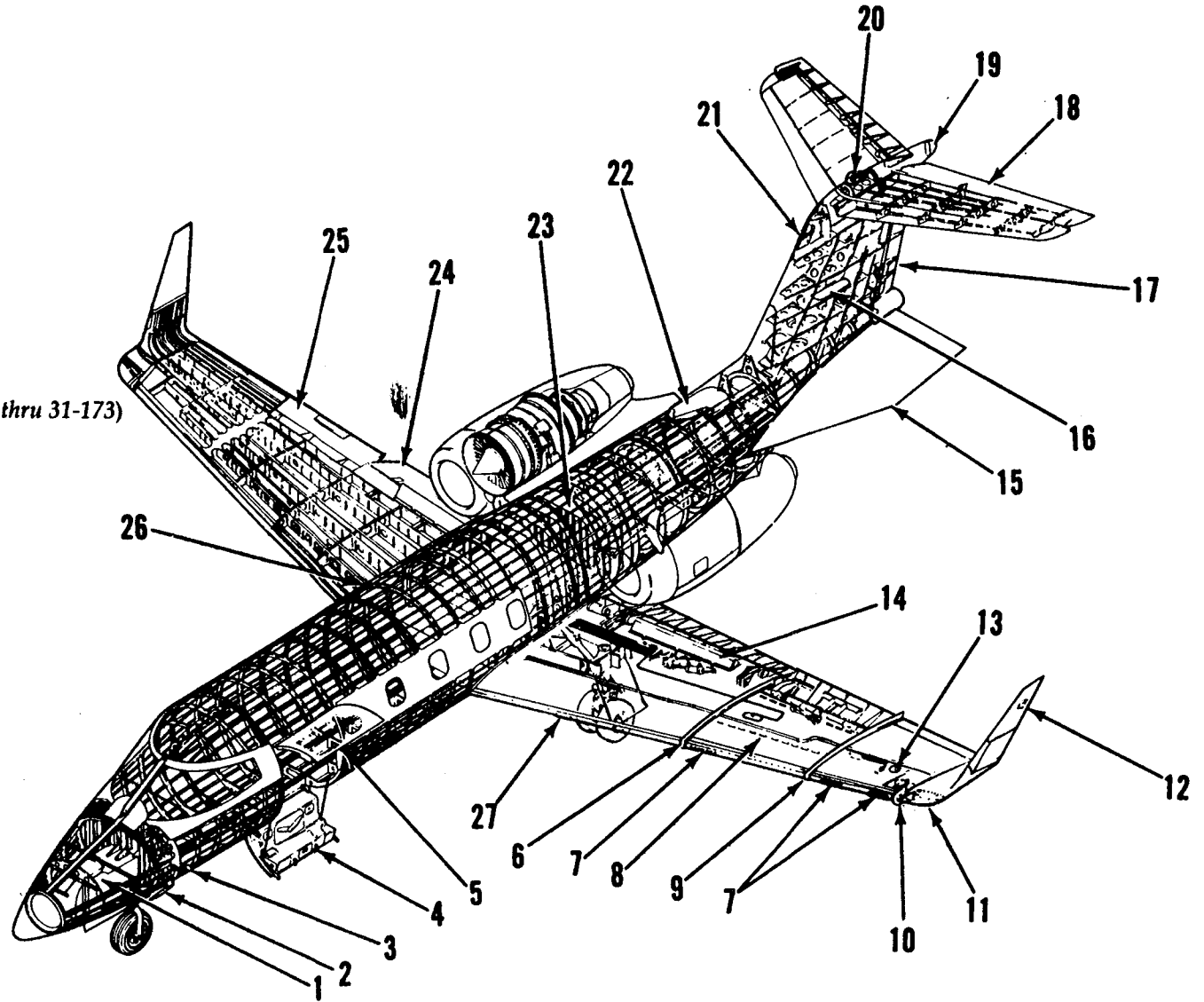

GENERAL ARRANGEMENT — EXTERIOR
Figure 1-2

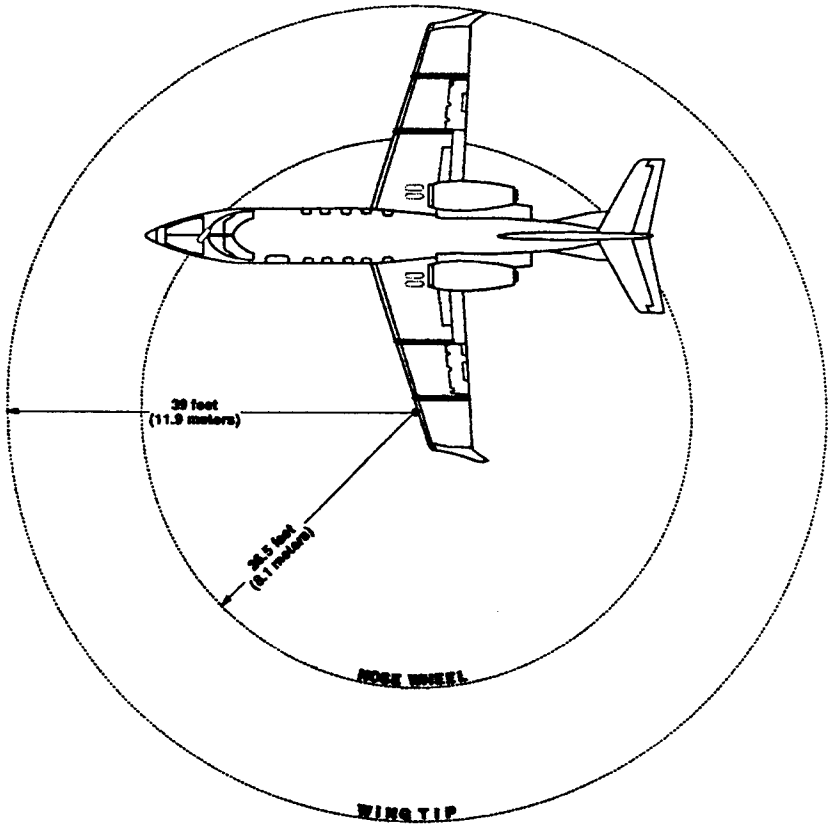

NOTE: Turning radius expressed above is based upon 50° nose-wheel deflection. Actual radius may vary as much as 3.5 feet (1.07 meters).

TURNING RADIUS
Figure 1-3

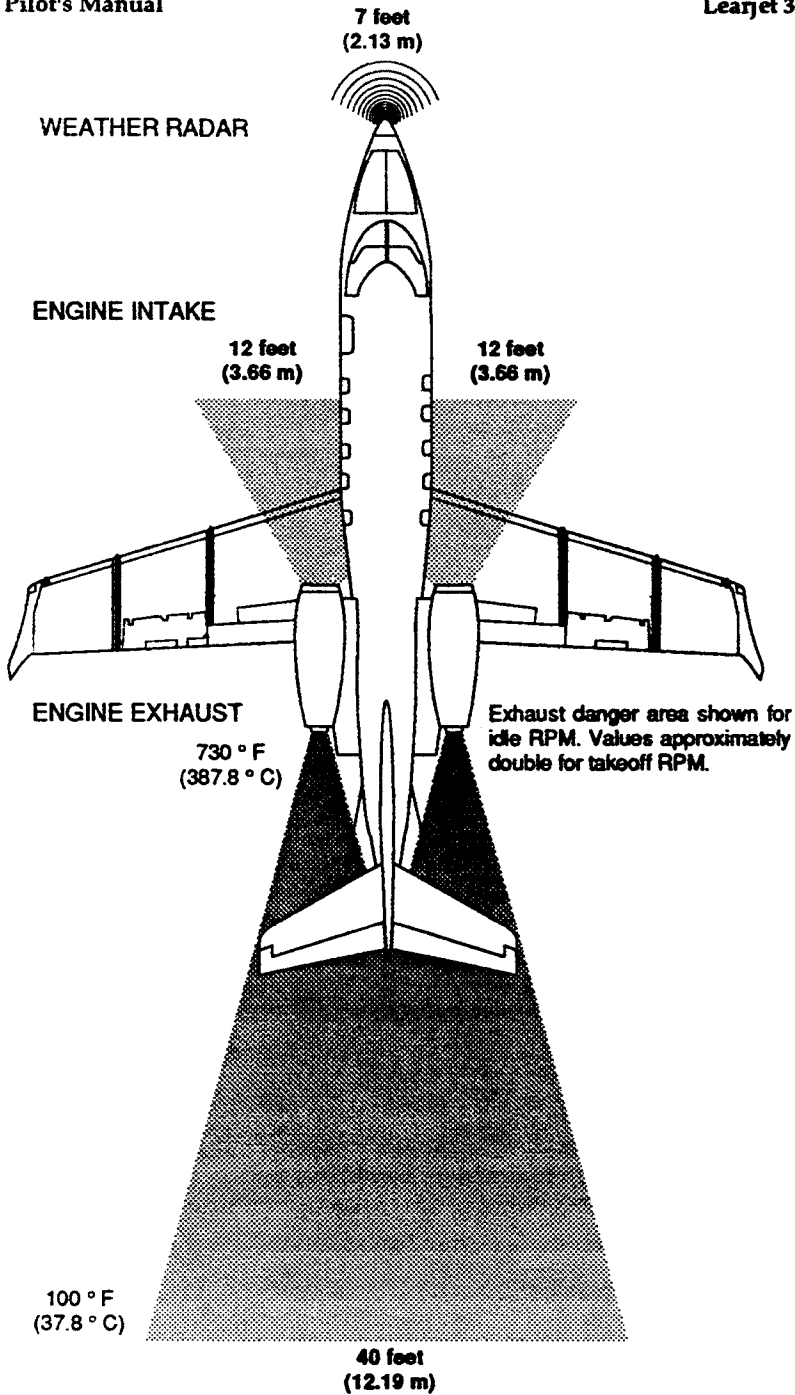

DANGER AREAS
Figure 1-4

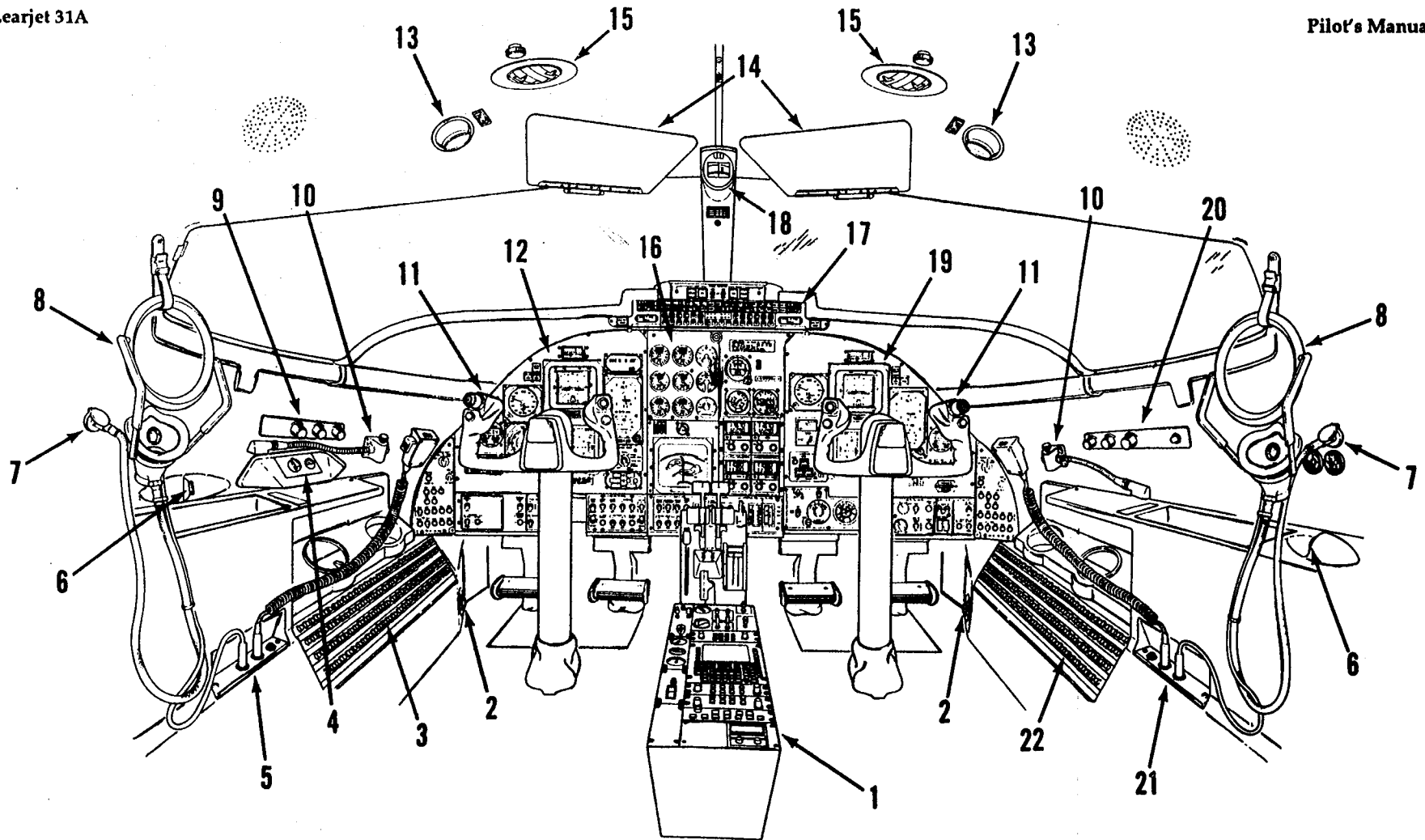

- | | |
|----------------------------------|-------------------------------------|
| 1. Pedestal | 12. Pilot's Instrument Panel |
| 2. Footwarmer (ankle outlet) | 13. Dome Light |
| 3. Pilot's Circuit Breaker Panel | 14. Sunvisor |
| 4. Oxygen Control Panel | 15. Overhead Air Outlet |
| 5. Pilot's Mic/Phone Jack Panel | 16. Center Instrument Panel |
| 6. Fresh Air Outlet | 17. Glareshield Annunciator Panel |
| 7. Oxygen Outlet | 18. Magnetic Compass |
| 8. Oxygen Mask | 19. Copilot's Instrument Panel |
| 9. Pilot's Dimmer Panel | 20. Copilot's Dimmer Panel |
| 10. Map Light | 21. Copilot's Mic/Phone Jack Panel |
| 11. Control Wheel | 22. Copilot's Circuit Breaker Panel |

GENERAL ARRANGEMENT — COCKPIT
Figure 1-5

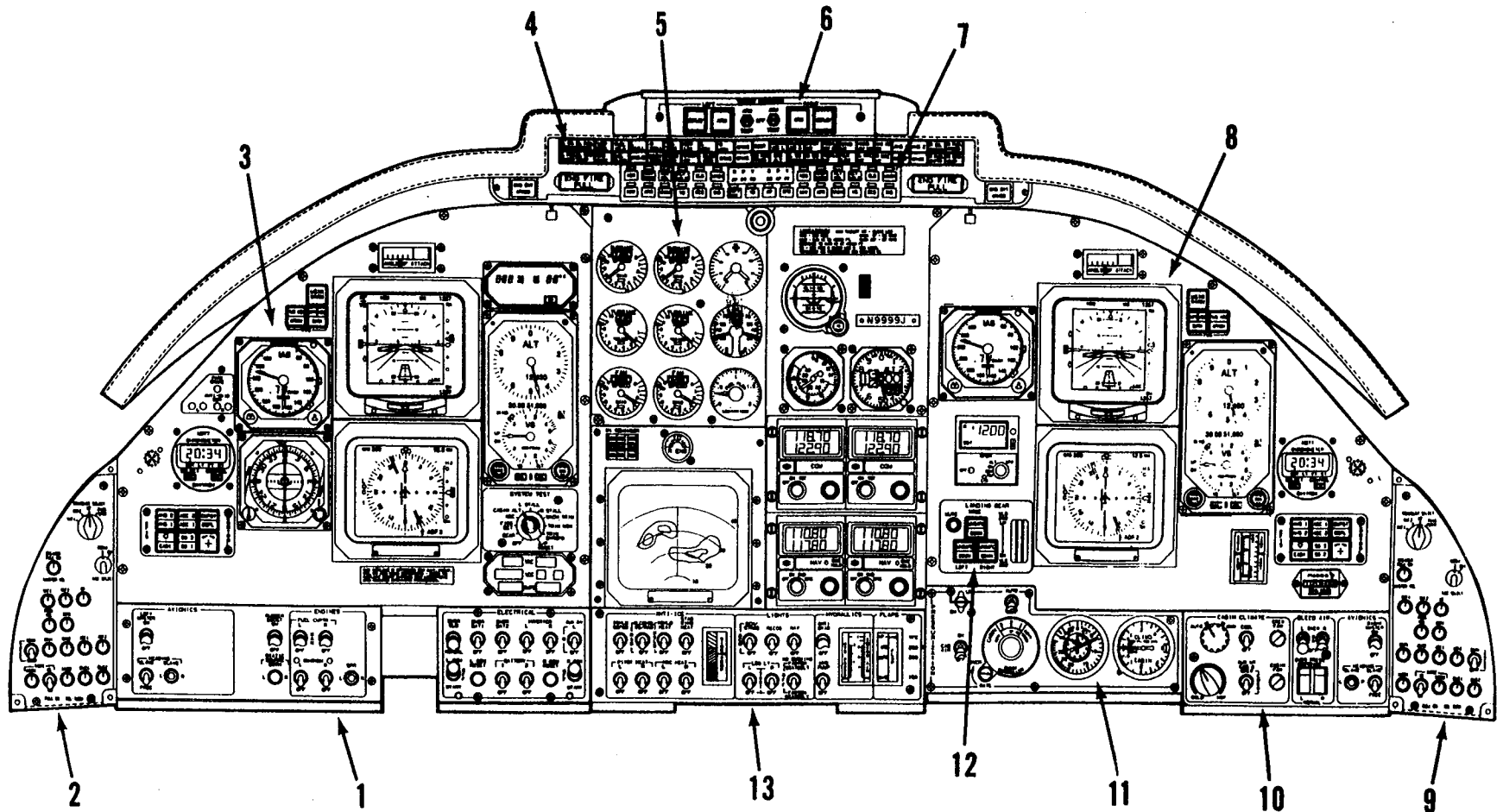

- | | |
|----------------------------------|--|
| 1. Pilot's Switch Panel | 8. Copilot's Instrument Panel |
| 2. Pilot's Audio Control Panel | 9. Copilot's Audio Control Panel |
| 3. Pilot's Instrument Panel | 10. Climate Control and Copilot's Switch Panel |
| 4. Glareshield Annunciator Panel | 11. Pressurization Control Panel |
| 5. Center Instrument Panel | 12. Landing Gear Control Panel |
| 6. Thrust Reverser Control Panel | 13. Center Switch Panel |
| 7. Autopilot Controller | |

INSTRUMENT PANEL (TYPICAL)
Figure 1-6

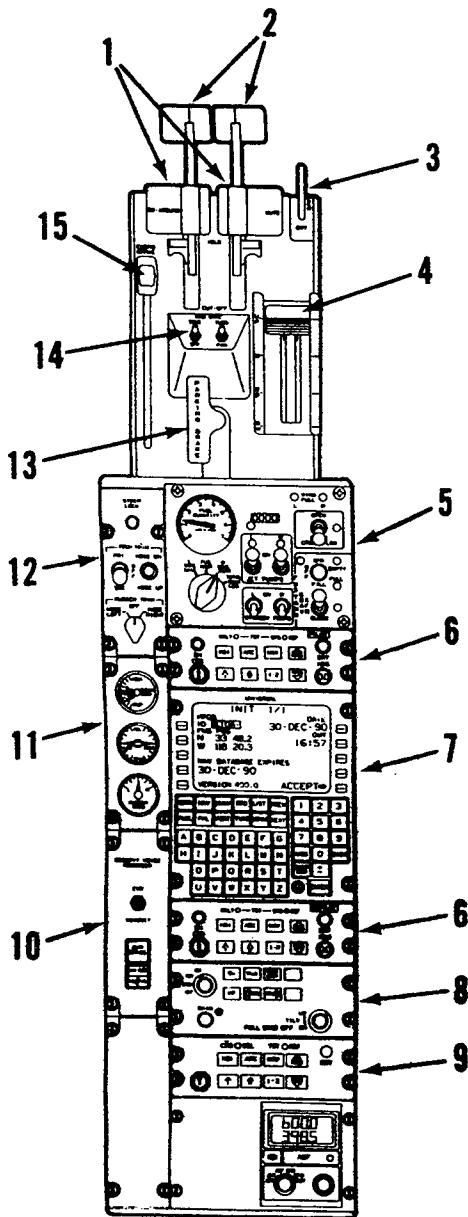

1. Thrust Levers
2. Thrust Reverser Levers
3. Spoiler Switch
4. Flap Switch
5. Fuel Control Panel
6. Pilot's and Copilot's EFIS Control Panels
7. FMS Control Display Unit
8. Weather Radar Control Panel
9. MFD Control Panel
10. Cockpit Voice Recorder Panel
11. Trim Indicator Panel
12. Trim Switch Panel
13. Parking Brake Handle
14. Engine Sync Switches
15. Emergency Brake Handle

PEDESTAL (TYPICAL)
Figure 1-7

INTENTIONALLY LEFT BLANK

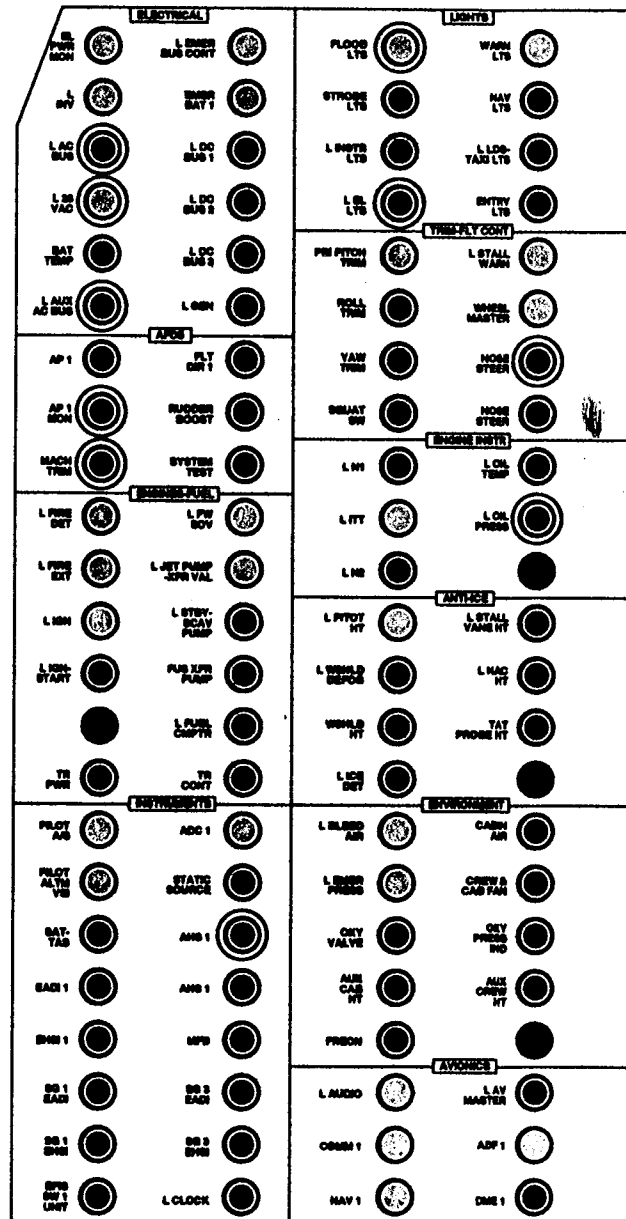

- Denotes AC circuit breakers.
- Denotes circuit breakers on the emergency bus.

PILOT'S CIRCUIT BREAKER PANEL
 (Aircraft 31-035 thru 31-060, 31-062 thru 31-065)
 Figure 1-8

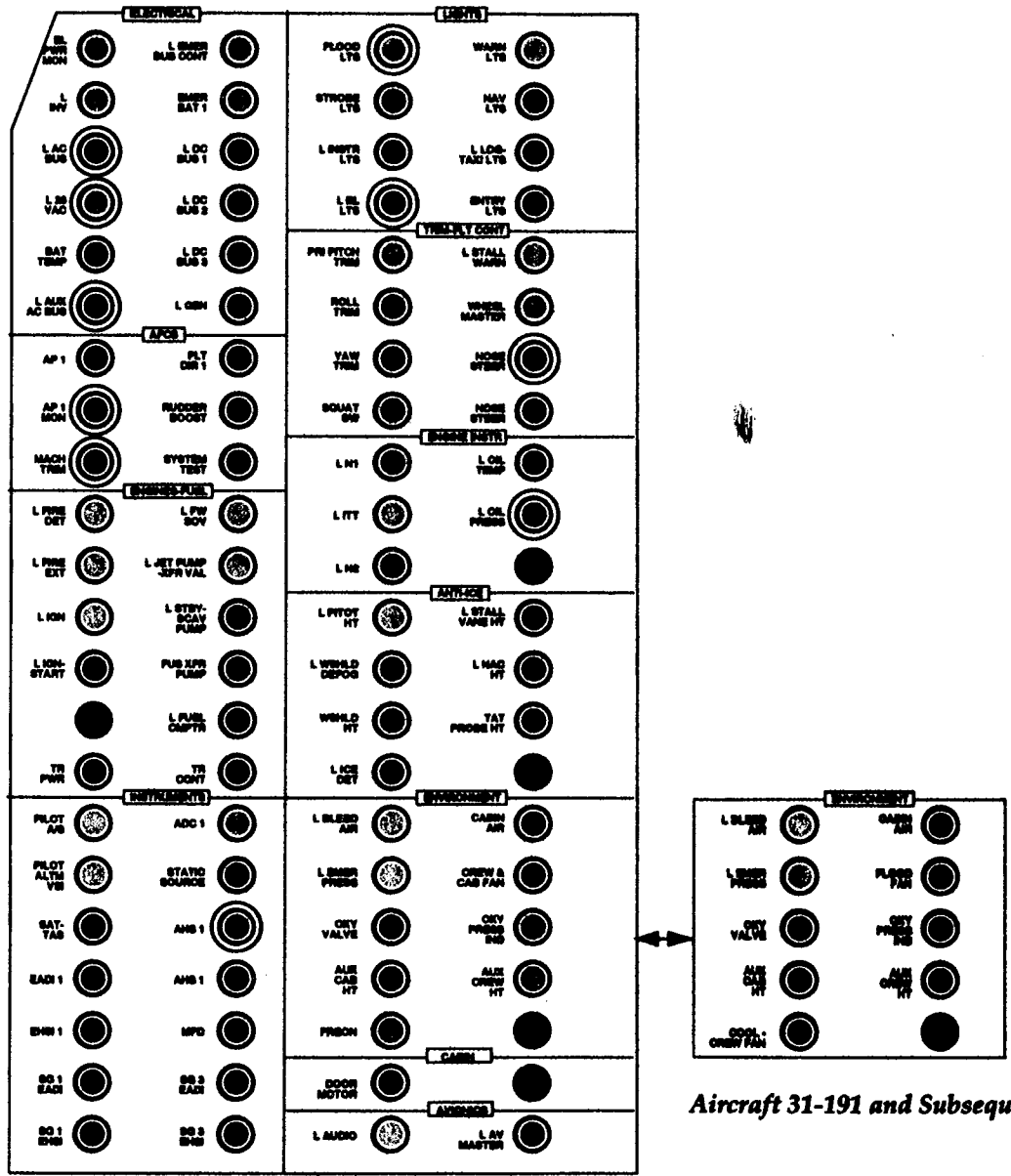



Aircraft 31-191 and Subsequent

⊗ Denotes AC circuit breakers.
 ⊙ Denotes circuit breakers on the emergency bus.

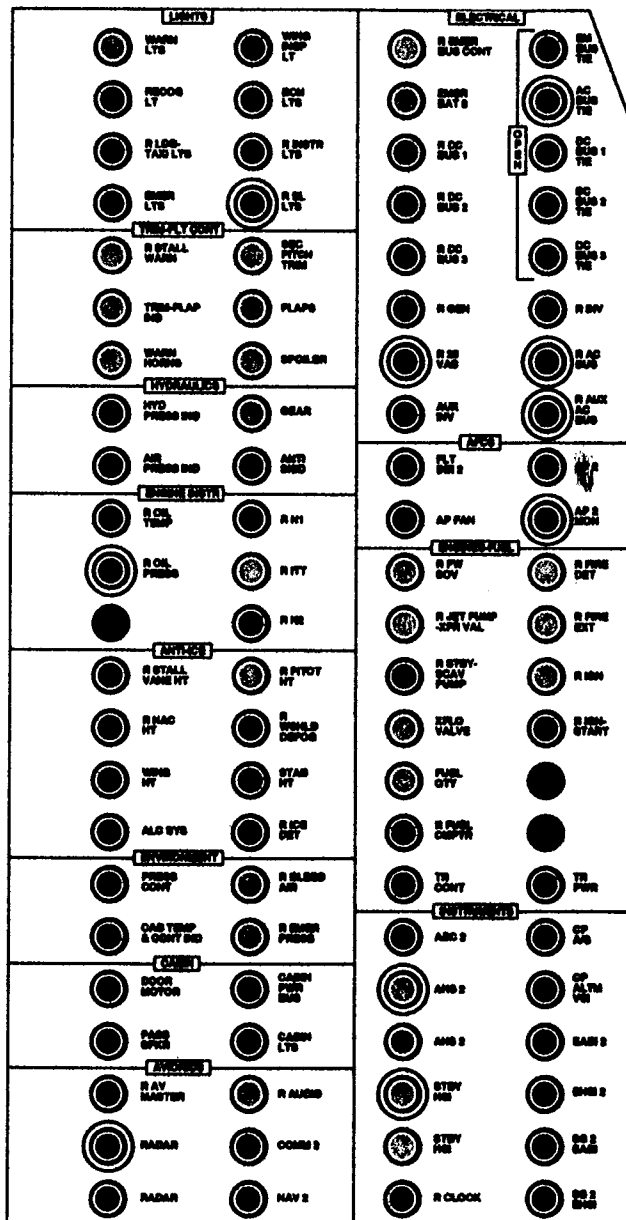
PILOT'S CIRCUIT BREAKER PANEL
 (Aircraft 31-061, 31-066 & Subsequent)
 Figure 1-9



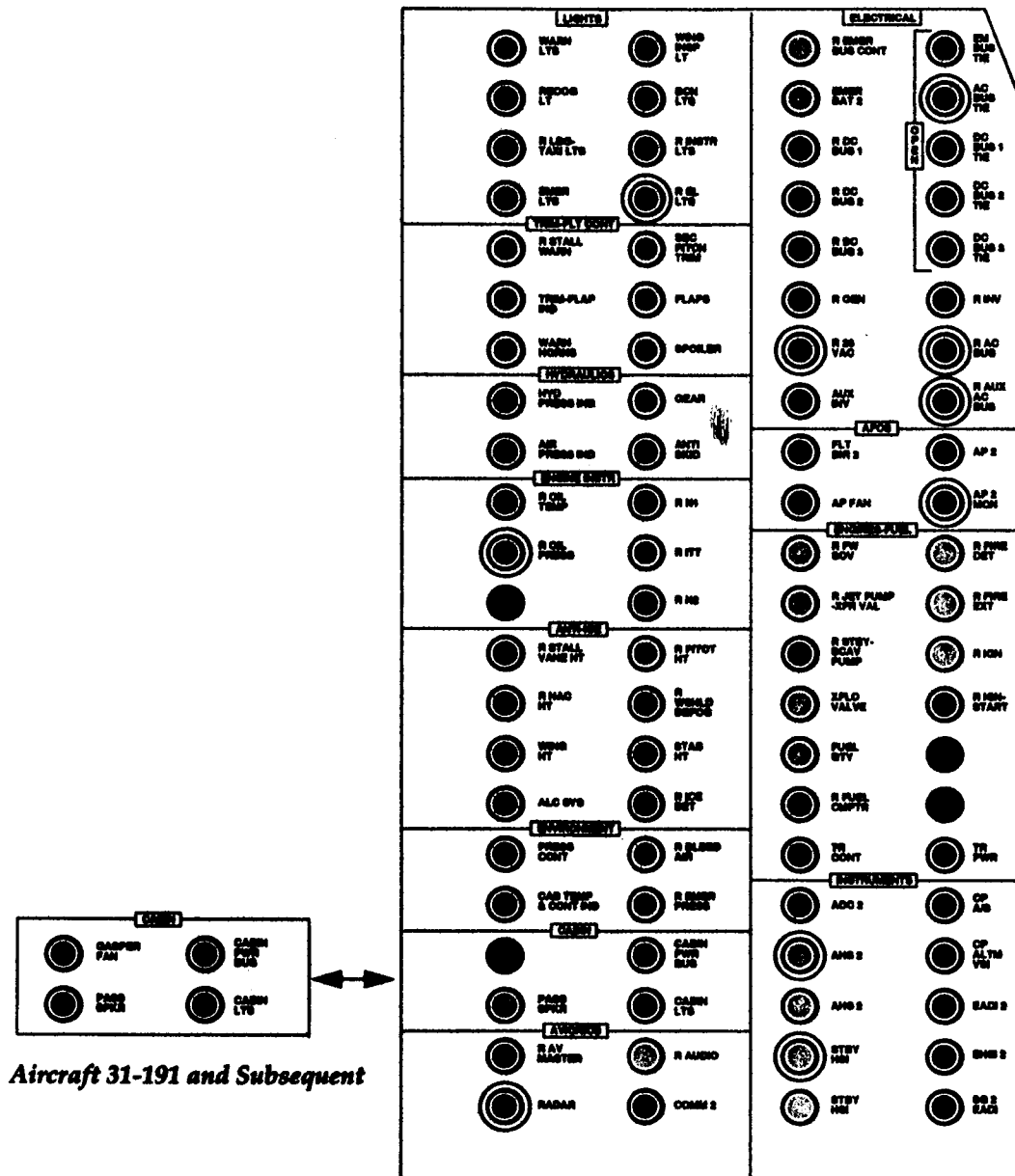

-  Denotes AC circuit breakers.
-  Denotes circuit breakers on the emergency bus.

COPILOT'S CIRCUIT BREAKER PANEL
 (Aircraft 31-035 thru 31-060, 31-062 thru 31-065)
 Figure 1-10



Aircraft 31-191 and Subsequent

-  Denotes AC circuit breakers.
-  Denotes circuit breakers on the emergency bus.

COPILLOT'S CIRCUIT BREAKER PANEL
 (Aircraft 31-061, 31-066 & Subsequent)
 Figure 1-11

NOTE: Pilot's seat shown. On copilot's seat, seat height, recline control and track lock are on opposite side.

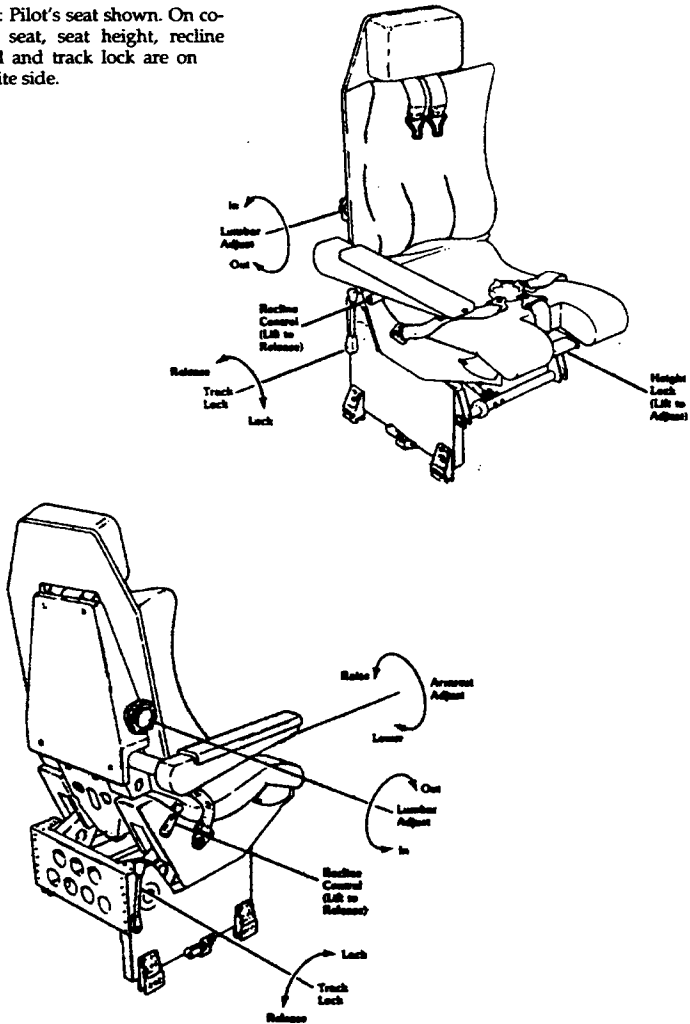

CREW SEATS
Figure 1-12