

1. INTRODUCTION

The water and waste systems include potable water, lavatory waste equipment and system controls.

Two potable water systems store and supply potable water to the galley and lavatory. The forward water system supplies potable water to the water dispenser and coffee maker in the galley. The aft water system supplies wash water to the lavatory sink. Both water systems are controlled from a single control panel located in the galley. Each water system has a servicing panel located on the right forward and aft external fuselage. Each servicing panel has controls for filling or draining of the related potable water system.

The lavatory waste system consists of a waste holding tank containing flushing fluid and a servicing panel. The servicing panel is located on the right aft external fuselage. System controls are provided to drain, rinse, prime and flush the toilet.

Canadair Regional Jet 100/200 - Water & Waste

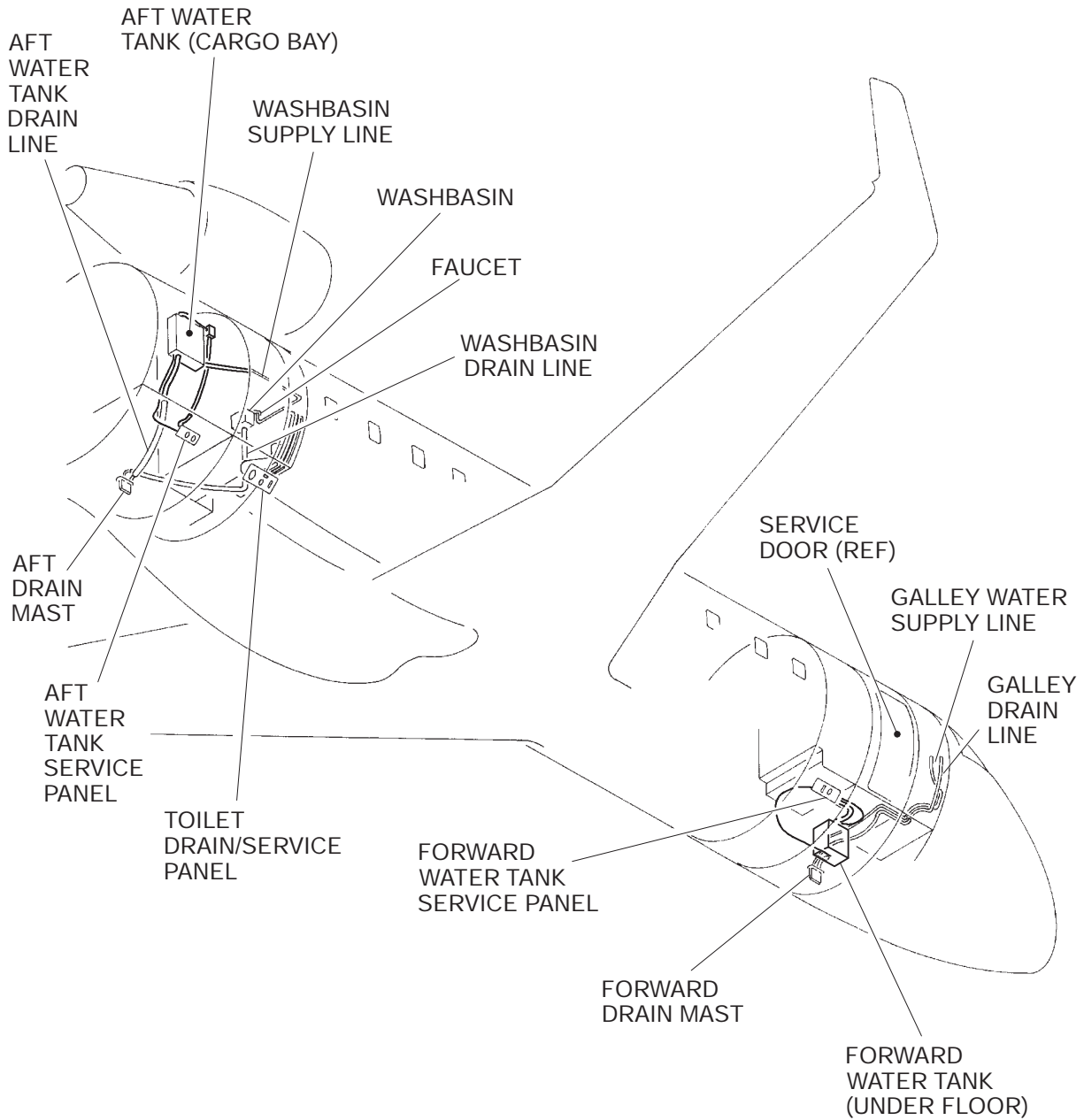

Potable Water and Waste Systems –General Arrangement
Figure 21–10–1

1. POTABLE WATER SYSTEM

The potable water system stores, supplies and controls the flow of water to the galley and lavatory. Potable water for the coffee maker, water dispenser and galley wash basin is stored in the forward water tank. Potable water for the lavatory wash basin is stored in the aft water tank. Each tank has a water level/temperature probe and a heater. System power on/off switches, water tank level lights and system circuit breakers are located on the galley control panel in the galley. The forward and aft water systems are independent, but are controlled by a single potable water system electronic control unit (ECU) located in the avionics compartment. The ECU controls the tank heaters, pumps and provides water level indications to the control panel.

Potable water is supplied to the galley from a single 5 USG (19 LTR) water tank located under the galley floor. Potable water is supplied to the galley by an ECU controlled pump, which maintains the water supply line pressure to the galley. The ECU controls the galley tank heater to maintain the water temperature between 10 to 20°C (50 - 68°F). Each tank heater contains a thermal fuse for overheat protection, which removes power to the heater when it exceeds a preset point and turns on the OVHT light on the galley control panel.

Potable water is supplied to the galley from a single 8 USG (30 LTR) water tank located under the galley floor. Potable water is supplied to the galley by an ECU controlled pump, which maintains the water supply line pressure to the galley. The ECU controls the galley tank heater to maintain the water temperature between 10 to 20°C (50 - 68°F). Each tank heater contains a thermal fuse for overheat protection which removes power to the heater when it exceeds a preset point and turns on the OVHT light on the galley control panel.

<0080>

Potable water is supplied to the lavatory sink from a single 5 USG (19 LTR) water tank located in the baggage compartment. Potable water is supplied to the lavatory by a pump which is controlled by the sink faucet selection. Wash basin water is heated to 25 ± 5°C (77 ± 9°F).

A water level/temperature probe is installed in each tank and supplies level and temperature information to the ECU. The ECU then uses the information to control the tank heaters and to illuminate the respective empty, 1/4, 1/2, 3/4 or full level indicator on the galley control panel.

Electrical power for the ECU, tank heaters and line heaters is controlled by the respective galley and lavatory ON/OFF switches on the galley control panel.

Effectivity:

- Airplanes Pre SB 601R-38-19 thru 22

Each system provides drainage of used water overboard through drain masts on the bottom of the fuselage. All components that could possibly freeze are heated and/or insulated to maintain the component temperature above the freezing point.



In flight, if the galley or lavatory ON/OFF switch is inadvertently selected OFF, power will be removed from the corresponding mast heater. Continued use of the respective drain system may cause ice accumulation on the drain mast which may detach and cause damage to the aircraft. <Pre SB 601R-38-19 thru 22>

Effectivity:

- Airplanes Post SB 601R-38-19 thru 22

Each system provides drainage of used water overboard through drain masts on the bottom of the fuselage. All components that are likely to freeze are heated and/or insulated to maintain the component temperature above the freezing point. The drain mast heaters are continuously powered from AC utility bus 2. This is done to prevent ice build-up on the drain masts, in flight, if the galley or lavatory ON/OFF switch is inadvertently selected OFF. Power can be removed from the drain masts by opening the LINE HTR circuit breakers on the potable water system control panel or by removing power from AC utility bus 2.

2. **SERVICING**

Each potable water system has a service panel located on the right side of the external fuselage. The galley service panel is forward and the lavatory service panel aft. Each service panel has a water fill port and a control handle.

When the control handle is positioned to the FILL position, water can be pumped into the system using the fill adapter. When the tank is full, water flows out through the overboard drain mast. When the control handle is placed in the DRAIN position and pulled, the potable water is drained from the tank through the drain mast.

Effectivity:

- Airplanes Post SB 601R-38-19 thru 22

When the control handle is positioned to the FILL position, water can be pumped into the system using the fill adapter. When the tank is full, water flows out through the overboard drain mast. When the control handle is placed in the DRAIN position and pulled, the potable water is drained from the tank through the drain mast. The control handle must be returned to the vertical (closed) position or the serving door will not close.

Canadair Regional Jet 100/200 - Water & Waste

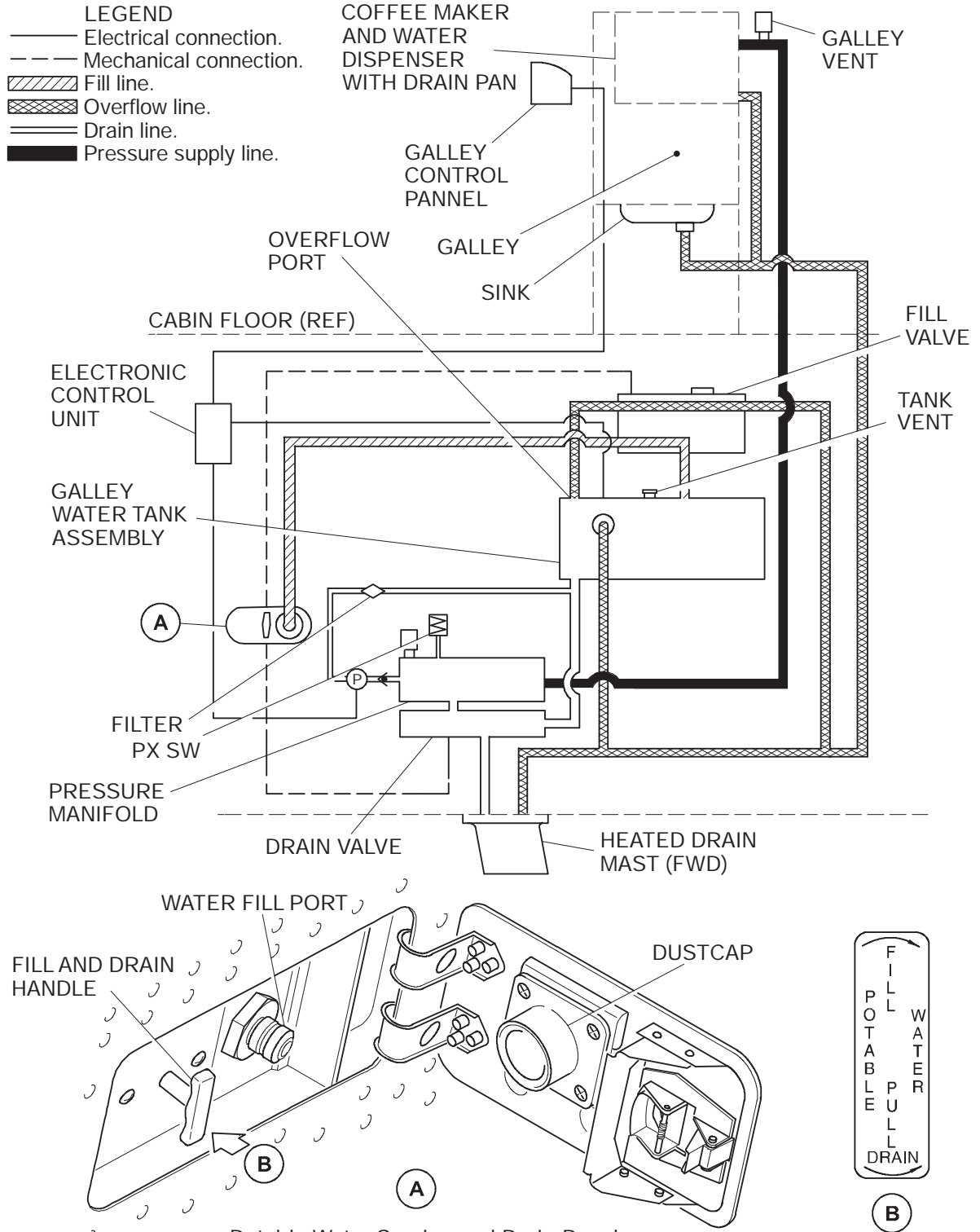

Potable Water Service and Drain Panel
Galley Potable Water System
Figure 21-20-1

Canadair Regional Jet 100/200 - Water & Waste

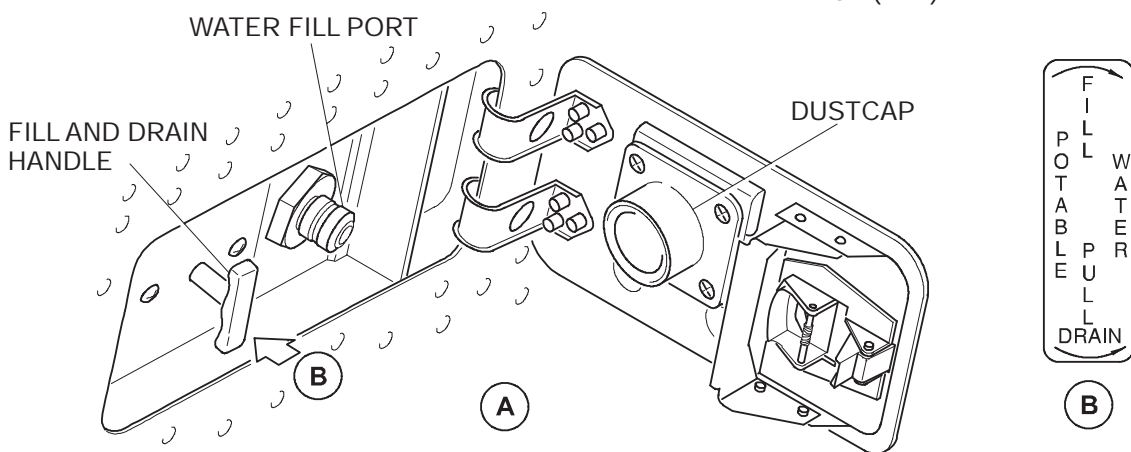
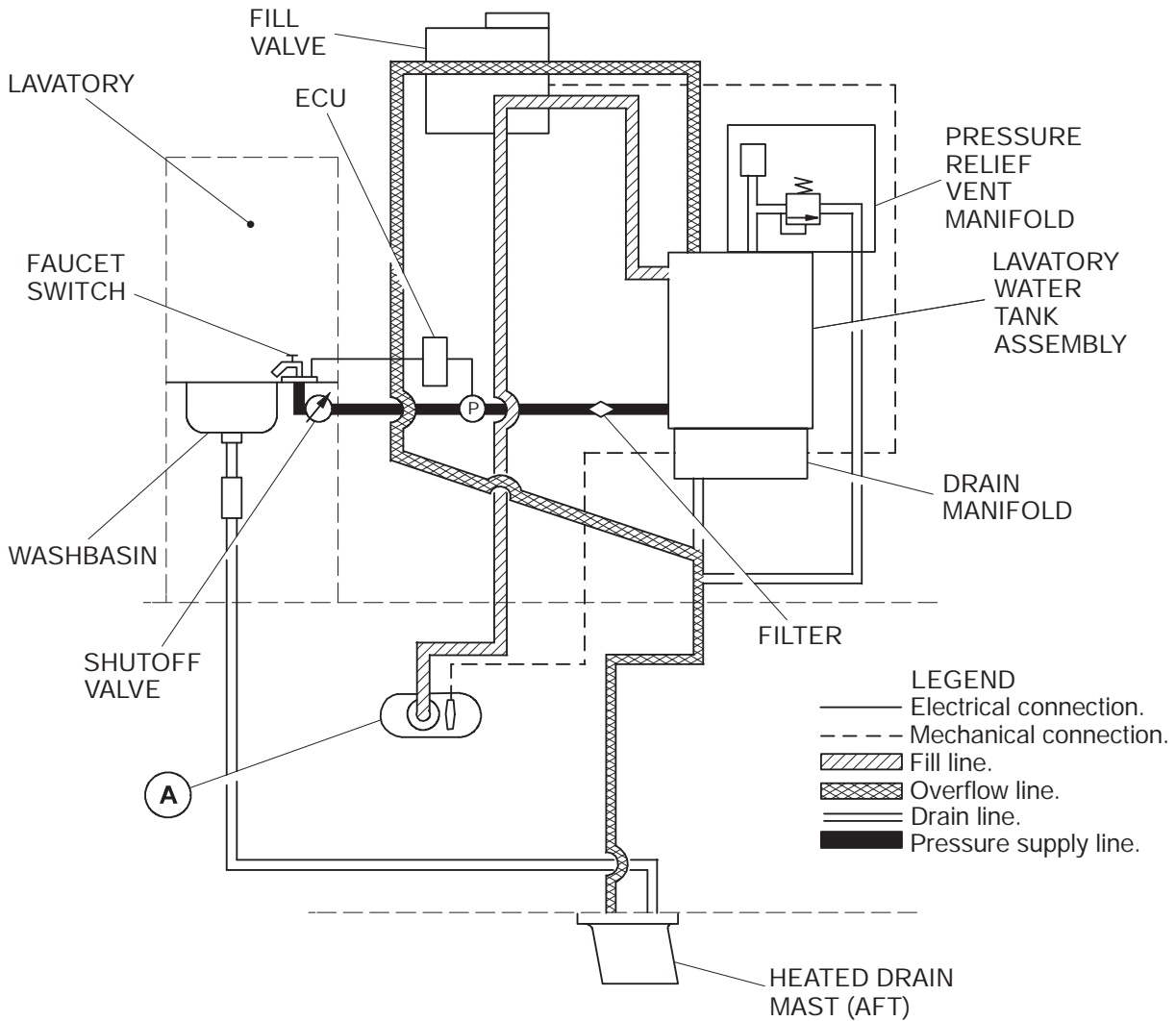

Potable Water Service and Drain Panel
Lavatory Water System
Figure 21-20-2

Canadair Regional Jet 100/200 - Water & Waste

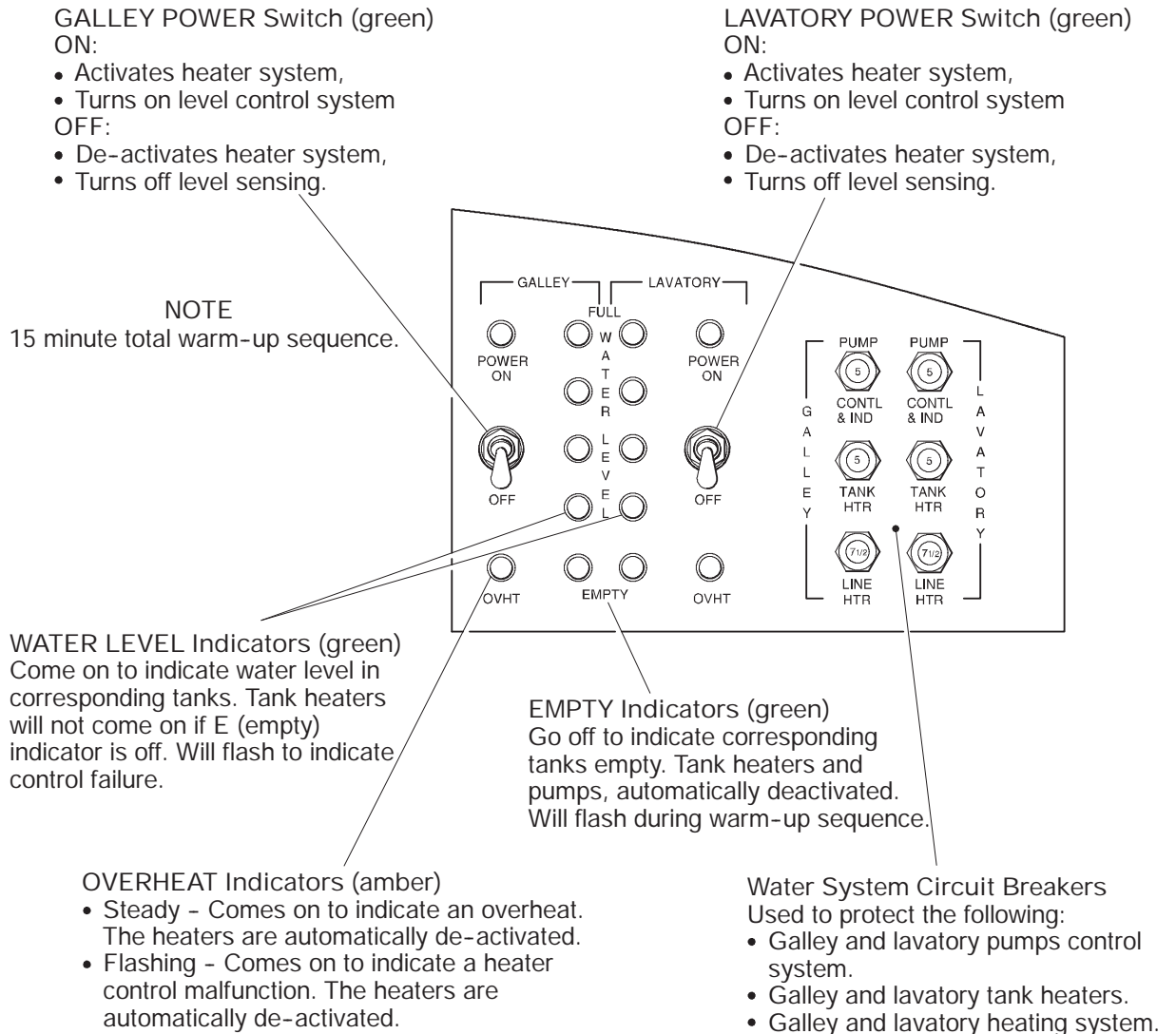

Galley Control Panel
Figure 21-20-3

Canadair Regional Jet 100/200 - Water & Waste

A. System Circuit Breakers

SYSTEM	SUB-SYSTEM	CB NAME	BUS BAR	CB PANEL	CB LOCATION	NOTES
Potable Water System	Potable Waste System	WASTE SYSTEM	DC SERVICE BUS	2	U4	
	Water System Control Logic	WATER CONT			U5	
	Lavatory Tank Heaters	WATER HTRS LINES	AC UTIL BUS 2		D13-D14	
	Lavatory Line Heaters	WATER HTRS TANKS			D15	
	Galley	Galley	GALLEY CONT & IND	DC SERVICE	Circuit Breakers are located on the Galley Control Panel	
			GALLEY TANK HTR	AC UTIL BUS 2		
			GALLEY LINE HTRS			
	Lavatory	Lavatory	LAVATORY CONT & IND	DC SERVICE		
			LAVATORY TANK HTR	AC UTIL BUS 2		
			LAVATORY LINE HTRS			

1. LAVATORY WASTE SYSTEM

The lavatory waste system stores waste material from the lavatory toilet and provides a means of flushing the toilet bowl. The toilet assembly is self-contained and consists of an integral seat and bowl assembly, holding tank, electric pump, timer, filter, flush handle and service panel.

The holding tank holds the deodorant flushing solution and waste material until removed by ground servicing personnel.

When the toilet flush handle is pushed, a timer energizes the electric pump for 10 seconds. The pump draws the flushing fluid from the tank, through a filter, and sends it out through the bowl assembly flush ring.

The system is serviced by means of a lavatory service panel, located on the right side of the aft fuselage. When the service vehicle drain line is connected to the drain port, the T-handle is pulled then rotated to the left. This opens the holding tank drain valve, on the bottom of the tank, allowing the tank to empty through the drain line.

Once the holding tank is emptied, rinsing agent and flushing fluid are sent through the charging port, flushing and cleaning the tank and lines. The T-handle is then turned to the right and pushed in to close the drain valve. The tank is then filled with precharge flushing fluid until the fluid level light on the service panel illuminates.

The toilet requires a precharge of 2.3 US gallons (8.7 liters) of flushing fluid.

Canadair Regional Jet 100/200 - Water & Waste

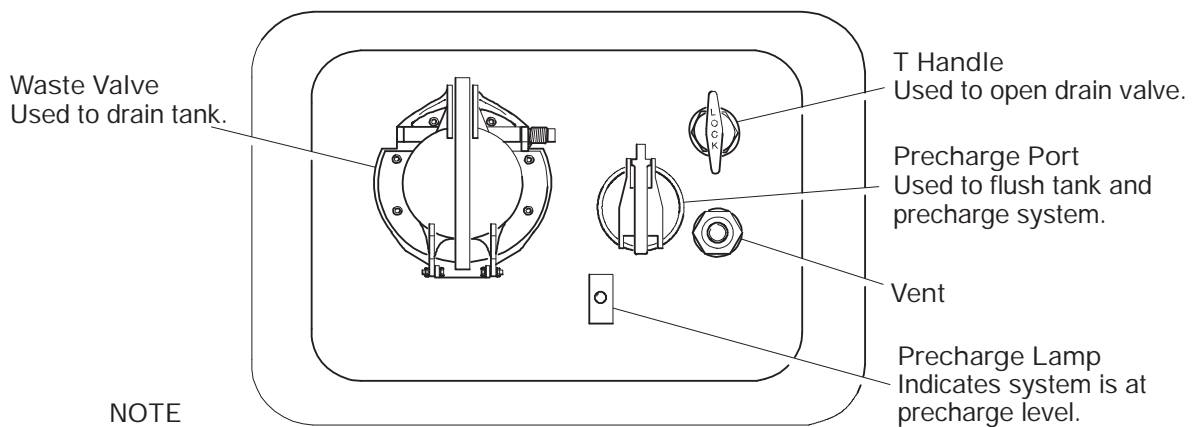
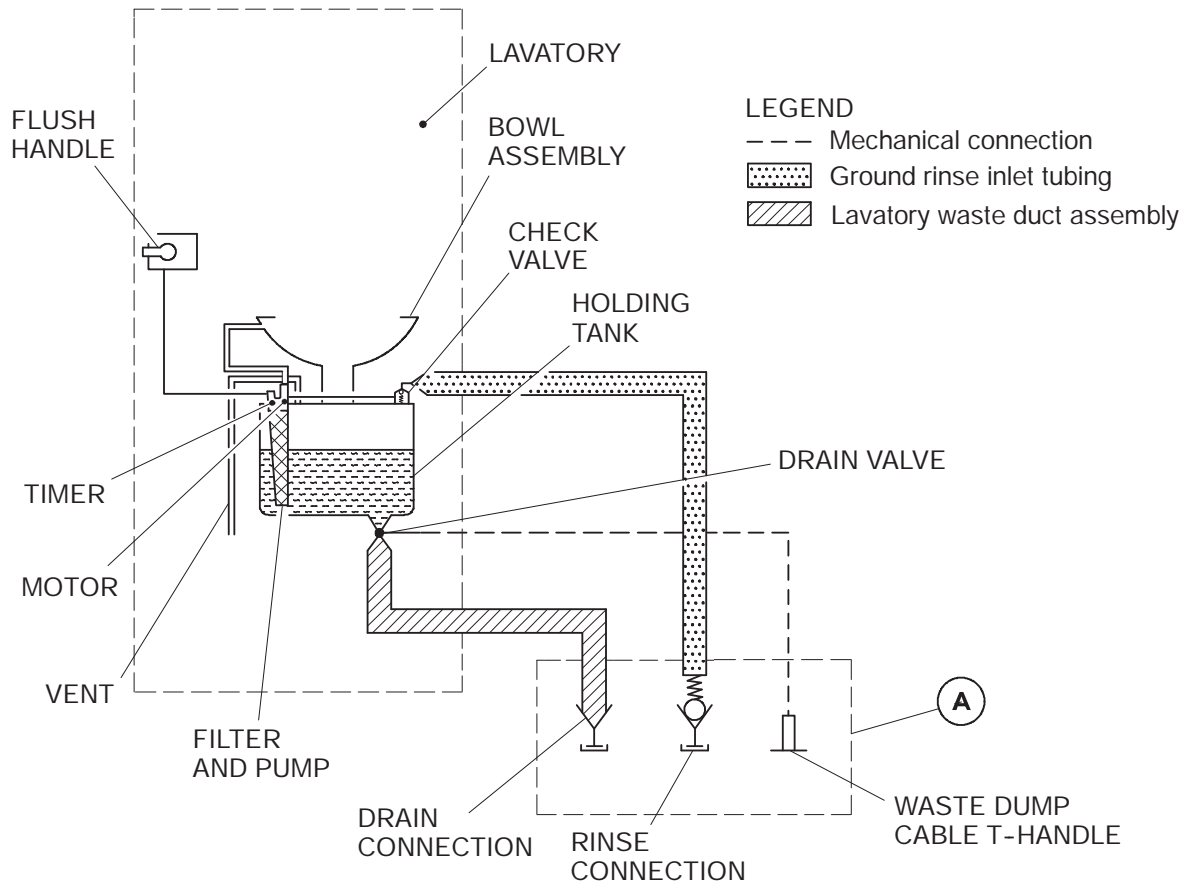

NOTE

Access panel can not be closed unless waste valve and precharge port covers are closed and locked and drain valve T handle is locked.

Lavatory Service Panel

Waste Disposal System
Figure 21-30-1

Canadair Regional Jet 100/200 - Water & Waste

A. System Circuit Breakers

SYSTEM	SUB-SYSTEM	CB NAME	BUS BAR	CB PANEL	CB LOCATION	NOTES
Lavatory Waste System	Toilet	TOILET	AC SERVICE	2	S2	
	Waste	WASTE SYST	DC SERVICE		U4	
		WATER CONT			U5	