

## **SECTION II**

# **ENGINES & FUEL**

### **TABLE OF CONTENTS**

Engines.....	2-1
Fuel Control Logic Diagram (Figure 2-1) .....	2-2
Engine Fuel and Control System.....	2-3
Thrust Levers.....	2-3
Engine-Driven Fuel Pump.....	2-4
Hydromechanical Fuel Control Unit .....	2-4
Digital Electronic Engine Control (DEEC) .....	2-5
Automatic Performance Reserve (APR).....	2-7
Engine Synchronizer .....	2-7
ENG CMPTR Switches .....	2-8
Surge Bleed Control.....	2-9
Fuel Heater /Oil Cooler.....	2-9
Engine Oil System .....	2-10
Engine Oil System Schematic (Figure 2-2) .....	2-11
Engine Ignition and Start Systems.....	2-13
Ignition System .....	2-13
IGN Switches .....	2-13
IGN Indications .....	2-13
Engine Start System.....	2-14
Start Switches.....	2-14
Start Indications.....	2-14
Engine Indicating (EI).....	2-15
Engine Vibration Monitor.....	2-15
Oil Temperature Indicator .....	2-15
Oil Pressure Indicator.....	2-16
Fuel Flow Indicator.....	2-16
N <sub>1</sub> Indicators.....	2-16
N <sub>2</sub> Indicators.....	2-17
ITT Indicators .....	2-17
Engine Diagnostic System (EDS) .....	2-19
EDS Record Switch .....	2-19
Engine Fire Detection System.....	2-20
SYS Test/Reset Switch.....	2-21
Fire Detection Function .....	2-21

**TABLE OF CONTENTS (Cont)**

Engine Fire Extinguishing System.....	2-22
L and R Engine Fire and Extinguisher #1/#2 Switches .....	2-23
Fire Extinguisher Discharge Indicators .....	2-23
Fire Extinguishing System (Figure 2-3).....	2-24
Thrust Reversers .....	2-25
Thrust Reverser Levers.....	2-26
Thrust Reverser Indications.....	2-27
Thrust Reverser System Schematic (Figure 2-4) .....	2-28
Aircraft Fuel System .....	2-29
Wing Tanks .....	2-29
Fuselage Tank.....	2-29
Fuel Flow Indicating System .....	2-30
Fuel Page (Figure 2-5).....	2-30
Fuel System Schematic (Figure 2-6).....	2-31
STBY Switches.....	2-33
XFLOW Switch and Crossflow Shutoff Valve.....	2-33
Fuel Indicating System .....	2-34
Refueling Control Panel.....	2-34
Fuel Quantity Signal Conditioner and Probes.....	2-35
Fuel Indicating System Schematic (Figure 2-7).....	2-36
Ram Air Fuel Vent System .....	2-37
Single-Point Pressure Refueling (SPPR) System .....	2-37
Precheck Valve.....	2-38
Fuel Additives.....	2-38
Refueling.....	2-38
Fuel Drains (Figure 2-8).....	2-39
Auxiliary Power Unit (APU).....	2-40
APU Cockpit Control Panel .....	2-42
APU Cockpit Control Panel (Figure 2-9).....	2-42
APU Maintenance Panel.....	2-43
APU Maintenance Panel (Figure 2-10).....	2-43
APU Fire Warning System .....	2-44
APU Bleed Air .....	2-44
APU Generator .....	2-44
Operational Procedures.....	2-45
APU Pre-Start Check.....	2-45
APU Start-Up .....	2-46
APU Shutdown .....	2-47
APU Shutdown Features (Automatic) .....	2-48
APU Circuit Breakers.....	2-48

# **SECTION II**

## **ENGINES & FUEL**

### **ENGINES**

The aircraft is powered by two TFE731-20 turbofan engines manufactured by Honeywell. These engines are two-spool, geared transonic-stage, front-fan, jet-propulsion engines. Each engine is rated at 3500 pounds (15.56 kN) thrust at sea level.

A spinner and an axial-flow fan are located at the forward end of the engine and are gear driven by the low-pressure (N1) rotor. The fan gearbox output-to-input speed ratio is 0.556. The low-pressure rotor consists of a four-stage low-pressure axial compressor and a three-stage low-pressure axial turbine, mounted on a common shaft. The high-pressure (N2) rotor consists of a single-stage centrifugal compressor and a single-stage air-cooled axial turbine, mounted on a common shaft. The high-pressure rotor drives the accessory gearbox through a transfer gearbox. The rotor shafts are concentric, so that the low-pressure rotor shaft passes through the high-pressure rotor shaft.

An annular duct serves to bypass fan air for direct thrust and also diverts a portion of the fan air to the low-pressure compressor. Air from the low-pressure compressor flows through the high-pressure compressor and is discharged into the annular combustor. Combustion products flow through the high- and low-pressure turbines and are discharged axially through the exhaust duct to provide additional thrust.

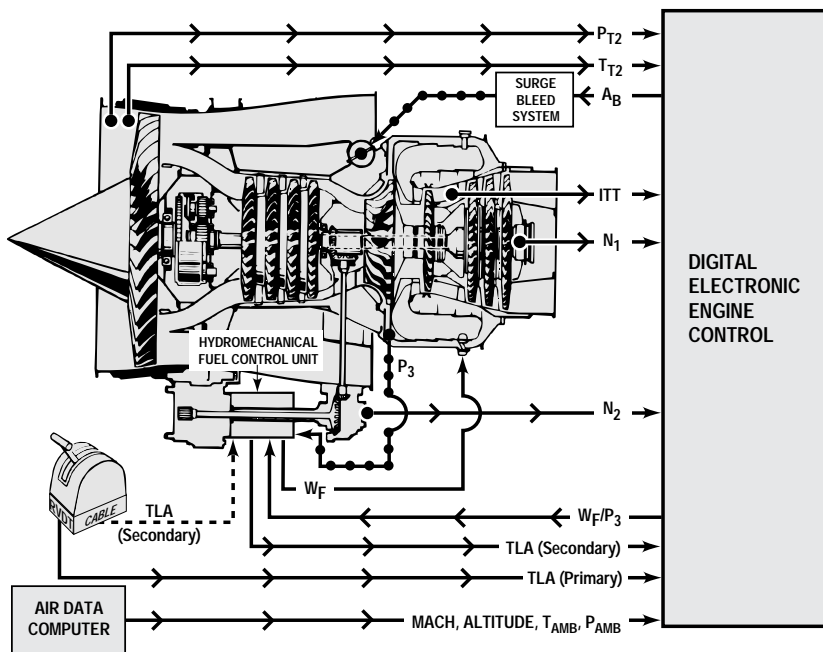

- FUEL
  - AIR
  - > ELECTRICAL
  - - - - - MECHANICAL
- A<sub>B</sub> — AREA BLEED
  - N<sub>1</sub> — LOW PRESSURE ROTOR (FAN) SPEED
  - N<sub>2</sub> — HIGH PRESSURE ROTOR (TURBINE) SPEED
  - P<sub>3</sub> — COMPRESSOR DISCHARGE PRESSURE
  - P<sub>T2</sub> — ENGINE INLET TOTAL PRESSURE
  - T<sub>T2</sub> — ENGINE INLET TOTAL TEMPERATURE
  - ITT — INTERSTAGE TURBINE TEMPERATURE
  - W<sub>F</sub> — FUEL FLOW
  - T<sub>AMB</sub> — AMBIENT TEMPERATURE
  - P<sub>AMB</sub> — AMBIENT PRESSURE
  - TLA — THRUST LEVER ANGLE

**FUEL CONTROL LOGIC DIAGRAM**  
**Figure 2-1**

## **ENGINE FUEL AND CONTROL SYSTEM**

The engine fuel and control system pressurizes fuel routed to the engine from the aircraft fuel system, meters fuel flow, filters the fuel, heats it as necessary to prevent filter icing, and delivers atomized fuel to the combustion section of the engine. The system also supplies high-pressure motive-flow fuel to the aircraft fuel system for jet pump operation. The major components of the system are the thrust levers, the engine-driven fuel pump, the hydromechanical fuel control unit, the Digital Electronic Engine Control (DEEC), surge bleed control valve and the fuel heater/oil cooler.

### **THRUST LEVERS**

Two thrust levers, located on the upper portion of the pedestal, are operated in a conventional manner with the full forward position being maximum power. Stops at the IDLE position prevent inadvertent reduction of the thrust levers to CUTOFF. The IDLE stops can be released by lifting a finger lift on the outboard side of each thrust lever. Detents are provided for CUTOFF, IDLE, Maximum Cruise (MCR), Maximum Continuous Thrust (MCT), Takeoff (T/O) and Automatic Performance Reserve (APR).

Primary Thrust Lever Angle (TLA) input to each DEEC is provided through Rotary Variable Differential Transformers (RVDTs) located within the thrust lever quadrant. Secondary TLA input is provided by a control cable connecting each thrust lever to the corresponding engine's hydromechanical fuel control unit.

A flight director go-around button is installed in the left thrust lever handle. An aural warning horn/voice mute button is installed in the right thrust lever handle. A thrust reverser control lever is mounted piggyback fashion on each thrust lever. Refer to THRUST REVERSERS in this Section for a functional description of the thrust reverser levers.

The Engine Indicating (EI) display will illuminate a green MCR, MCT, T/O or APR for the corresponding thrust lever detents.

## ENGINE-DRIVEN FUEL PUMP

The engine-driven fuel pump provides high-pressure fuel to the engine fuel control system as well as motive-flow fuel for operation of the aircraft jet pumps. The pump consists of a low-pressure pump element, high-pressure pump element, high-pressure relief valve, filter, filter bypass valve, and motive-flow provisions.

The fuel pump is mounted to the accessory drive gearbox of the engine. Fuel entering the first stage low-pressure element is pressurized to flow through the fuel heater/oil cooler and filter. A second flow path for this fuel is to the Auxiliary Motive Flow Pump (AMFP). The fuel from the AMFP is used to operate the various jet pumps in the wing tanks. Fuel that is supplied to the fuel heater/oil cooler and filter is passed on to the pump high-pressure element. The high-pressure element provides fuel at the fuel pressures required by the hydromechanical fuel control unit. The high-pressure relief valve protects the fuel pump and hydromechanical fuel control unit from extreme fuel pressure surges. A fuel filter bypass valve begins to open at a pressure differential of 9 to 12 psi (62 to 82 kPa) and allows flow of unfiltered fuel to the inlet of the high-pressure pump.

The following CAS illuminations are specific to the fuel pumps:

CAS	Color	Description
FUEL PRESS LOW	Red	Fuel pressure is low at the associated (L or R) engine's fuel pump inlet.
FUEL FILTER	White	The engine or wing fuel filter, on the associated (L or R) side, is becoming clogged.

## HYDROMECHANICAL FUEL CONTROL UNIT

The hydromechanical fuel control unit meters the required amount of fuel to the engine combustor that corresponds to TLA, atmospheric and engine operating conditions. The unit is mounted on the fuel pump and contains the hydromechanical fuel metering section, thrust lever input and position potentiometer, shutoff valve, and a mechanical governor. The mechanical governor functions as an overspeed governor for the high-pressure rotor. In addition, the mechanical governor provides manual control when the DEEC is deactivated. When activated, the DEEC controls fuel scheduling by means of a torque motor located within the hydromechanical fuel control unit. The torque motor controls the metering section of the hydromechanical fuel control unit.

## **DIGITAL ELECTRONIC ENGINE CONTROL (DEEC)**

A DEEC is provided for each engine. The DEEC is basically an N1 governor with provisions for fuel limits during acceleration and deceleration. The DEEC performs governing, limiting, and fuel scheduling functions for engine start and continuous operation.

Input parameters utilized by the DEEC for controlling functions are: engine inlet pressure (PT2), engine inlet temperature (TT2), interstage turbine temperature (ITT), low-pressure rotor speed (N1), high-pressure rotor speed (N2), and Thrust Lever Angle (TLA).

Output signals from the DEEC to control engine operation go to the hydromechanical fuel control unit, surge bleed valves and ignitors.

The crew is able to control the engine through the DEEC by changing the TLA input to change desired thrust level. Primary TLA is received from the RVDT. Secondary TLA is sensed by the DEEC from a potentiometer within the hydromechanical fuel control unit during manual mode operation.

TT2 and PT2 input is provided by a temperature/pressure sensor integrated into the inlet duct. The sensor contains an electrical element for sensing temperature (TT2). Inlet pressure (PT2) is applied directly to the DEEC through a flexible line. An electrical heating element on the sensor provides protection against icing. The PT2 line from the sensor shall be treated as an aircraft pitot line with a drain trap located at the low point for draining possible moisture accumulation. In the normal operating mode, the DEEC analyzes the TT2 and PT2 inputs and produces output signals which are sent to a torque motor in the hydromechanical fuel control unit for fuel flow control and to the control solenoids of the surge bleed valves.

ITT is measured by thermocouple probes that extend into the gas path between the high-pressure (N2) and low-pressure (N1) turbines.

The N1 speed signals are produced by a dual element monopole located in the rear bearing housing and are the primary thrust indicating instruments. The N2 speed signal is produced by a dual element monopole located in the transfer gearbox. Both dual element monopoles provide outputs to the DEEC and EICAS for flight deck display. Output signals from the DEEC for engine control are also directed to a torque motor in the hydromechanical fuel control unit and to the control solenoids of the surge bleed valves.

The DEEC has an extensive self-monitoring and fault analysis system. In the event a minor fault is detected in the system, the DEEC will initiate an ENGCMPTTR FAULT white CAS when ENG CMPTR switch is in the ON position. If electrical power to the computer is lost, the manual mode solenoid valve is deenergized closed, engine control reverts to manual mode, and an ENGCMPTTR FAULT amber CAS illuminates.

If a major fault occurs in the DEEC, it may remain in the auto mode or it may revert to manual mode depending on the fault. In either case, the ENGCMPTTR FAULT amber CAS will illuminate. A MAN amber EI will also illuminate if DEEC has reverted to manual mode.

When engine control automatically reverts to manual mode, it will not go back to normal mode until the pilot cycles the ENG CMPTR switch. If the CAS doesn't clear, the fault condition still exists. At this point, the pilot may select the MAN position which will result in the ENGCMPTTR FAULT amber CAS changing to white.

Whenever engine control is in the manual mode of operation, a MAN amber or white EI will illuminate. If engine control has reverted to manual because of a DEEC fault or failure, MAN will illuminate amber. If manual mode was selected by the pilot, MAN will illuminate white.

Engine operation during manual mode is maintained through the secondary TLA and mechanical linkage to the hydromechanical fuel control unit.

Power to the DEEC is 28-vdc supplied from the L and R ESS buses through the 7.5-amp L and R CMPTR circuit breakers located within the ENGINE groups of the respective pilot's and copilot's circuit breaker panels.

The following CAS illuminations are specific to the DEEC:

CAS	Color	Description
ENGCMPTTR FAULT	Amber	There is a major fault in the associated (L or R) engine computer system.
ENGCMPTTR FAULT	White	There is a minor fault in the associated (L or R) engine computer system.

The DEEC also functions to provide the crew with automatic performance reserve and engine synchronization.



## AUTOMATIC PERFORMANCE RESERVE (APR)

Automatic Performance Reserve (APR) provides a change in thrust on the operating engine in the event of opposite engine thrust loss during takeoff and missed approach conditions. The APR is controlled by the APR switch located on the aft portion of the pedestal. Depressing the switch illuminates the white ARM on the switch and the DEEC performs a software verification. If the APR circuits are active for both engines, an APR white EI will then appear at the top of the EICAS once the system is armed by the DEECs. When armed, each DEEC monitors the opposite engine in order to automatically increase the maximum available thrust if the opposite engine fails. An APR ON green EI will illuminate during automatic APR activity or manual activation. APR may be manually activated by advancing the thrust lever to the APR detent. The engine synchronizer will not function during APR operation.

The following CAS illumination is specific to the APR:

CAS	Color	Description
APR FAULT	White	APR fault is detected in the associated (L or R) DEEC.

## ENGINE SYNCHRONIZER

The engine synchronizer system consists of a three position ENG SYNC N1/N2/OFF switch (located on the aft pedestal), engine synchronizer circuits, and data crosslink communication lines integrated within the DEECs. The synchronizer will function from flight idle to the maximum power rating as long as the engines are operating within the system authority limits. The authority limits are:  $\pm 5\%$  N1 during midrange operation, 0% at takeoff TLA, and -2% to +5% at flight idle. During flight, the engine synchronizer, if selected, will maintain the two engines' N1 or N2 in sync with each other. The engine synchronizer must not be used during takeoff, landing, or single-engine operations.

If N1 is selected, SYNC green or amber EI will illuminate between the N1 indicators. If N2 is selected, SYNC green or amber EI will illuminate between the N2 indicators. The light will be green if the landing gear is up and amber if the gear is down. ENG SYNC should be OFF for takeoff and landing; therefore, the amber color is to alert the crew to turn the synchronization system off if the landing gear is down.

Synchronization is accomplished by maintaining the speed of the slave engine in sync with the speed of the master engine. The master engine is determined and so designated during installation.

The following criteria must be satisfied before the system will operate:

- The ENG SYNC switch is set to N1 or N2.
- The difference between the N1 speed of each engine is no more than 5%.
- Thrust reversers are stowed.
- APR is disarmed.

Deviating from any of these criteria will cancel engine synchronization.

Electrical power for the ENG SYNC switch is 28-vdc supplied through the 1-amp SYNC SW circuit breaker located within the ENGINE group of the pilot's circuit breaker panel.

#### ENG CMPTR SWITCHES

The DEECs are controlled by the L and R ENG CMPTR switches located in the respective L and R ENGINE panels. Normally, the switches are left in the ON position. The ON position allows full DEEC authority of engine operation through inputs with the pilot's primary TLA. If normal engine control is not satisfactory, the engine can be operated in the manual mode.

The manual mode can be activated by placing the ENG CMPTR switch to either MAN or OFF. If the ENG CMPTR switch is placed in the MAN position, the manual mode solenoid (within the hydromechanical fuel control unit) is deenergized closed, the engine fuel control is in the manual mode and the DEEC is no longer controlling the engine. However, if electrical power is still available, the DEEC will monitor N1 and N2 and provide ultimate overspeed protection. If the ENG CMPTR switch is placed to OFF or electrical power is lost, operation is the same, except the ultimate overspeed protection is no longer available. The OFF position of the ENG CMPTR switch disconnects power to the DEEC.

## SURGE BLEED CONTROL

A surge bleed control system for each engine is installed to prevent low-pressure compressor surge. Each system consists of two externally mounted surge valve control solenoids and an internally mounted surge bleed valve. During normal operation, surge bleed valve position is controlled by the DEEC via the solenoid control valves. Once the DEEC transfers to manual mode, the surge bleed valve will go to the 1/3-open position.

## FUEL HEATER /OIL COOLER

Each engine is equipped with a fuel heater/oil cooler. The fuel heater/oil cooler is provided for the purpose of heating the fuel sufficiently to prevent ice formation in the engine system, and to provide oil cooling to the planetary gearbox. The fuel heater/oil cooler is of a liquid-to-liquid design utilizing the engine lubricating oil as a source of heat to warm the fuel. This heat transfer conversely cools the oil.

Fuel heater/oil cooler faults are detected by the Data Acquisition Unit (DAU). The DAU interprets the temperature as a function of engine oil temperature and uses the result to illuminate a CAS message.

The following CAS illuminations are specific to the fuel heater/oil cooler:

<b>CAS</b>	<b>Color</b>	<b>Description</b>
FUEL HEATER	Amber	The fuel heater, on the associated (L or R) engine, is not keeping the fuel warm enough.
FUEL HEATER	White	The fuel heater, on the associated (L or R) engine, is heating the fuel too much.

## ENGINE OIL SYSTEM

Oil for engine lubrication is drawn from the engine oil tank by the oil pump. The oil is output from the pump through a filter, a pressure regulator valve, an oil-to-air cooler, and a fuel heater/oil cooler. The oil-to-air cooler is a three-segment, finned cooler that forms the inner surface of the fan duct. From the oil-to-air cooler, the oil flow is divided so that part of the oil is directed to the accessory drive and transfer gearboxes, and the engine shaft bearings. The remaining oil is diverted to a fuel heater/oil cooler and then to the planetary gearbox.

The oil filter assembly incorporates a bypass valve and an electrical switch to indicate when the oil filter is clogged or clogging. In the event of an impending bypass, an L or R OIL FILTER white CAS will illuminate. The bypass valve will open when the pressure differential across the filter reaches 35 psi (241 kPa) allowing oil to bypass the filter. Under cold oil conditions, such as engine start, the bypass indication is inhibited when the oil temperature is less than approximately 100° F (38° C); however, the bypass valve will still open. This function prevents nuisance indications during engine start due to high oil viscosity at cold temperatures.

The following CAS illumination is specific to the engine oil system:

<b>CAS</b>	<b>Color</b>	<b>Description</b>
OIL FILTER	White	The associated (L or R) engine oil filter is becoming plugged.

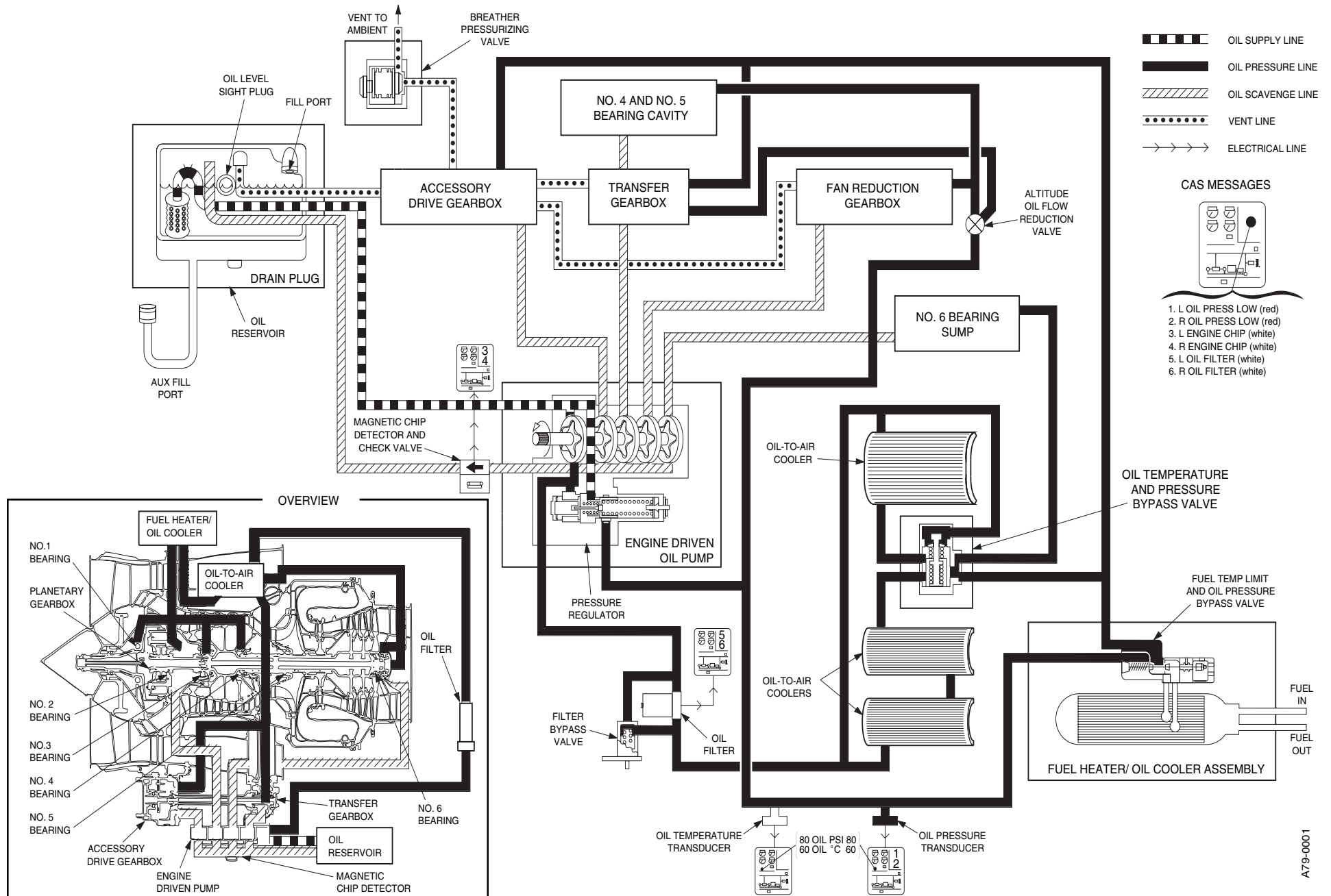

**ENGINE OIL SYSTEM SCHEMATIC  
Figure 2-2**

## ENGINE IGNITION AND START SYSTEMS

### IGNITION SYSTEM

The engine ignition system is an integral sub-system of the engine. Each engine consists of an ignition unit, two ignitor plugs, two shielded high-voltage output cables and associated aircraft wiring. During normal engine operation the system is controlled by the DEEC and is capable of continuous operation. The DEEC powers the ignition system for three modes of operation. The first is for normal engine start. During normal engine start the DEEC commands ignition at  $>6.0\%$   $N_2$  and turns ignition off when  $N_1 = 0.7$  of idle  $N_1$ . The second mode is for uncommanded deceleration, and the third mode prevents engine flame-out during rapid deceleration.

The ignition unit is a solid-state, high-voltage, capacitor-discharge unit mounted on the fan bypass duct of each engine. The unit provides a spark rate of 2 sparks per second at an output of 18,000 to 24,000 volts through the ignitor plugs. The ignitor plugs are located on the combustor plenum at the 4 and 8 o'clock positions. These iridium plugs are linked to the ignition unit by separate high-voltage cables and spark when pulsed by the ignition unit.

The ignition system is powered by 28-vdc from the L and R ESS buses through the CH A and CH B circuit breakers located within the ENGINE groups (respective L and R IGN) of the pilot's and copilot's circuit breaker panels.

### IGN SWITCHES

The L and R IGN switches, located in the respective ENGINE panel of the pedestal, are used to obtain continuous engine ignition. The switch controlling the left engine ignition system is labeled L IGN. The switch controlling the right engine ignition system is labeled R IGN. When an IGN switch is placed in the ON position, 28-vdc is applied to the engine ignition unit.

### IGN INDICATIONS

The EI will display a green, white, and amber IGN. The green EI represents normal ignition activity. A white EI is generated if one ignitor plug is not firing. The amber EI alerts the pilot of dual ignitor plug failure.

## ENGINE START SYSTEM

A combined starter/generator is mounted on the front of the accessory gearbox. For normal starts, the DEEC provides for automatic starting which allows the thrust lever to be moved into the IDLE position before activating the starter. When the respective L or R START switch is momentarily depressed, the DEEC begins the start sequence by activating the corresponding standby fuel pump and energizing the starter relay closed. The starter relay connects electrical power to the starter from the respective L or R GEN bus. Power to the GEN buses is supplied from the aircraft batteries, an external power source, or an Auxiliary Power Unit (APU) (if installed).

An external power source or APU is recommended for starts when ambient temperature is 32° F (0° C) or below. Ensure an external power source supply is regulated to 28-vdc, has adequate capacity for engine starting and is limited to 1500 amps maximum. Allow the operating generator amperage to decrease below 300 amps prior to a generator cross-start. Refer to Cold Weather Operation, AFM, for additional information when operating in extremely cold weather.

### START SWITCHES

The L and R START switches, located in the respective ENGINE panel of the pedestal, are guarded momentary action switches that illuminate ON when depressed indicating the starter relay is energized.

### START INDICATIONS

During engine starts, a vertical START green or amber EI will appear. The green EI represents normal starter activity. The amber EI represents an engine starter engaged with N<sub>2</sub> greater than 51%.

## ENGINE INDICATING (EI)

### ENGINE VIBRATION MONITOR

The engine vibration monitor system consists of an accelerometer mounted on each engine and a tailcone-mounted engine vibration monitor signal conditioner. The vibration monitor signal conditioner consists of two identical independent channels.

Each channel is powered by the corresponding 3-amp L or R VIB MON circuit breaker located within the ENGINE group of the respective pilot's or copilot's circuit breaker panels.

The following CAS illumination is specific to the engine vibration monitor system:

CAS	Color	Description
ENG VIB MON	White	Vibration level, in the associated (L or R) engine, is higher than normal.

### OIL TEMPERATURE INDICATOR

Oil temperature is displayed for each engine as a white digital readout. The display consists of an OIL °C legend with temperature readouts to the left and right. An engine-mounted transducer transmits oil temperature signals to the DAU. The DAU then provides an oil temperature value for EICAS. Refer to the following table for temperature ranges and corresponding color displays during normal engine operation:

ALTITUDE FT	WHITE °C	AMBER °C	RED °C
≤30,000	30 to 127	-53 to 29	-60 to -54 and 128 to 175
>30,000	30 to 140	-53 to 29	-60 to -54 and 141 to 175



**OIL PRESSURE INDICATOR**

Oil pressure is displayed for each engine as a digital readout on EICAS. The display consists of an OIL PSI legend with pressure readouts to the left and right.

Refer to the following table for pressure ranges and corresponding color display during normal engine operation:

(% N <sub>2</sub> )	WHITE PSIG	AMBER PSIG	RED PSIG
≤80% and up to 3 minutes after engine start	65 to 80	50 to 64	0 to 49 and 126 to 150
>80% or more than 3 minutes after engine start	65 to 80	50 to 64	0 to 49 and 101 to 150

**FUEL FLOW INDICATOR**

Fuel flow is displayed for each engine as a white digital readout on EICAS. The display consists of a FF PPH legend with flow rates to the left and right. The fuel flow rates are presented in Pounds-Per-Hour (PPH). A fuel flow transmitter located in the main fuel line of each engine supplies fuel flow signals to the DAU via a fuel flow converter. The DAU then provides a fuel flow rate value for EICAS presentation.

**N<sub>1</sub> INDICATORS**

The fan speed (N<sub>1</sub>) analog EI for each engine consists of a needle, arc, and N<sub>1</sub> bug with integral digital readouts for N<sub>1</sub> and N<sub>1</sub> setting. The N<sub>1</sub> sensor is mounted in the engine's rear bearing support housing and senses low-pressure fan speed. The sensor provides signals to the DEEC and DAU. Refer to the following table for N<sub>1</sub> speeds and corresponding color display.

WHITE % N <sub>1</sub>	AMBER % N <sub>1</sub>	RED % N <sub>1</sub>
0 to 100.0	N/A	100.1 to 115*

\*Above 115% the digits are invalid.

## N<sub>2</sub> INDICATORS

N<sub>2</sub> is displayed for each engine as a digital readout. The display consists of an N<sub>2</sub> legend with digital readouts to the left and right. Refer to the following table for N<sub>2</sub> speeds and corresponding color display for various conditions.

% N <sub>2</sub>	WHITE % N <sub>2</sub>	AMBER % N <sub>2</sub>	RED % N <sub>2</sub>
Except APR Mode	0 to 100	100.1 to 102.5	102.6 to 115*
APR Mode	0 to 101	101.1 to 102.5	102.6 to 115*

\*Above 115% the digits are invalid.

## ITT INDICATORS

Interstage Turbine Temperature (ITT) is displayed for each engine as a needle and arc with an integral digital readout for ITT. The arc is scaled to start at 100° C. Interstage turbine temperature for each engine is sensed by Chromel-Alumel parallel wired thermocouples positioned between the high- and low-pressure turbine sections. The signal from the averaging circuit of the thermocouples is carried to the DEEC and DAU for EI display. Refer to the following table for ITT and corresponding color display for various conditions.

*Aircraft 45-002 & Subsequent not modified by SB 45-72-1:*

OPERATING MODE	WHITE °C	AMBER °C	RED °C
Start	0 to 941	N/A	942 to 1014
Takeoff (≤5 minutes)	0 to 941	N/A	942 to 1014
Takeoff or APR (>5 minutes)	0 to 916	917 to 941	942 to 1014
APR (≤5 minutes)	0 to 963	N/A	964 to 1014
Up To MCR	0 to 900	N/A	901 to 1014
MCT (no anti-ice)	0 to 916	N/A	917 to 1014
MCT (any anti-ice)	0 to 941	N/A	942 to 1014

*Aircraft 45-002 & Subsequent modified by SB 45-72-1:*

<b>OPERATING MODE</b>	<b>WHITE °C</b>	<b>AMBER °C</b>	<b>RED °C</b>
Start	0 to 991	N/A	992 to 1014
Takeoff (no anti-ice) (≤5 minutes)	0 to 991	N/A	992 to 1014
Takeoff (any anti-ice) (≤5 minutes)	0 to 991	N/A	992 to 1014
Takeoff or APR (>5 minutes)	0 to 1013	N/A	1014
APR (≤5 minutes)	0 to 1013	N/A	1014
Up To MCR	0 to 974	N/A	975 to 1014
MCT (no anti-ice)	0 to 991	N/A	992 to 1014
MCT (any anti-ice)	0 to 991	N/A	992 to 1014

## ENGINE DIAGNOSTIC SYSTEM (EDS)

An Engine Diagnostic System (EDS) is installed to provide engine fault recording and condition trend monitoring. The system periodically records engine parameters and allows the crew to request that conditions be recorded at any time. Normal use of the system entails downloading data from the DEEC and submitting to the engine manufacturer for timely analysis. The data may be downloaded at any time to assist in diagnosing engine problems which may be encountered. The EDS is intended for maintenance functions only and not for in-flight monitoring or diagnosis by the flight crew. The system is integrated into the DEEC of each engine.

### EDS RECORD SWITCH

The EDS RECORD switch is located on the aft pedestal. The purpose of the switch is to allow the flight crew to initiate data collection by the EDS. When the switch is actuated, the engine parameters existing four minutes prior to and one minute after switch actuation will be recorded in the EDS memory.

The following CAS illuminations are specific to the engine diagnostic system:

CAS	Color	Description
CHECK EDS	White	Indicates one of the following about the associated (L or R) engine diagnostic system (EDS): <ul style="list-style-type: none"><li>• The EDS has lost power.</li><li>• The EDS built-in test equipment (BITE) has detected a system failure.</li><li>• The EDS memory is 80% full.</li><li>• The system has detected an engine condition which is out of acceptable parameters.</li></ul>

## ENGINE FIRE DETECTION SYSTEM

Three heat-sensing elements connected in series are located in each engine nacelle to detect an engine fire. One element is located around the accessory gearbox; one is located around the engine tailcone; and another around the engine firewall. The fire detection system is controlled by two fire detect control boxes located in the tailcone. In the event of an engine fire, the applicable control box will sense a resistance change in the sensing elements and flash the master WARN lights in the glareshield and applicable FIRE switch located within the L or R ENGINE panel of the aft pedestal.

The FIRE red EI will flash within the arc of the ITT dial. Warning is given if the firewall or accessory gearbox area exceeds approximately 410° F (210° C), or the engine tailcone area exceeds approximately 890° F (477° C).

Whenever an engine fire is detected a "LEFT" or "RIGHT ENGINE FIRE" voice message will sound to both pilots' headphones and flight deck speakers. This voice message is continuous, but can be silenced by depressing the mute switch located on the right thrust lever or the master WARN light.

Electrical power for the system is 28-vdc supplied through the 1-amp L and R FIRE DET circuit breakers located within the ENGINE group of the pilot's and copilot's circuit breaker panels respectively. Fire detect systems are powered from the respective L and R ESS buses.

**SYS TEST/RESET SWITCH**

## FIRE DETECTION FUNCTION

The rotary-type SYS TEST/RESET switch on the forward pedestal is used to test the fire detection system. Rotating the switch to FIRE DET and depressing the switch (PRESS TEST) button will connect a resistance into both fire detect system circuits. This resistance, simulating an engine fire, will test system indications as follows:

- Master WARN tone and light will activate followed by a "LEFT ENGINE FIRE . . . RIGHT ENGINE FIRE" voice.
- Both red FIRE and all white EXTINGUISHER #1 and #2 ARMED switches (ENGINE panel) will illuminate. Illumination of the FIRE switch indicates continuity of the fire detect systems and illumination of the EXTINGUISHER #1 and #2 ARMED switches indicate continuity of the fire extinguisher squibs.
- Red FIRE messages in ITTs will flash.



Both red FIRE messages on RMU ENGINE PGE 1 will flash next to the N1 display.

- L and R BLEED AIR LEAK red CAS and CWP. This indicates continuity of the bleed air overheat sensor system.
- WING/STAB LEAK red CAS and CWP. This indicates continuity of the anti-ice bleed air overheat sensor system.
- APU FIRE Switch (if installed) and a red CAS will illuminate with the APU MASTER Switch ON. The red CAS only will illuminate if the APU MASTER Switch is Off.



Depressing and holding the SYS TEST/RESET Switch in the FIRE DET position for 15 seconds will result in the APU fire horn sounding. Holding the switch for 30 seconds will result in an APU FAIL indication and APU shutdown.

## ENGINE FIRE EXTINGUISHING SYSTEM

The engine fire extinguishing system components include: two spherical extinguishing agent containers, a red FIRE PUSH light/switch for each engine, two white EXTINGUISHER #1 and #2 ARMED light/switches for each engine, one hydraulic shutoff valve for each engine, one fuel shutoff valve for each engine, a thermal discharge indicator, a manual discharge indicator, and associated wiring and plumbing. The system also utilizes the pneumatic system bleed air shutoff valves. The system is plumbed to provide the contents of either or both extinguishing agent containers to either engine nacelle. Shuttle valves are installed to prevent extinguishing agent flow between containers. The extinguishing agent, Halon 1301 (Bromotrifluoromethane [CF<sub>3</sub>Br]), is stored under pressure (600 psi) in the extinguisher containers and a pressure gauge on each container is visible from inside the tailcone. Halon 1301 is non-toxic at normal temperatures and is non-corrosive. As Halon 1301 is non-corrosive, no special cleaning of the engine or nacelle area is required in the event the system has been used. The system operates on 28-vdc supplied through the 5-amp L and R FIRE EXT circuit breakers located within the respective ENGINE group of the pilot's and copilot's circuit breaker panels. Fire extinguishing systems are powered from the EMER BATT hot bus.

## **L AND R ENGINE FIRE AND EXTINGUISHER #1/#2 SWITCHES**

The engine fire extinguishing system is operated through the L and R FIRE switches and the EXTINGUISHER #1 and #2 switches located in the respective L and R ENGINE panel on the aft pedestal. Activating the applicable FIRE switch will cause the following events:

- Close the respective shutoff valves. (Refer to Figure 2-3.)
- CLOSED indication will appear on respective FIRE switch. Flashing FIRE PUSH illumination goes to steady.
- Arm the extinguishing agent containers.
- EXTINGUISHER #1 and #2 light illuminated.
- Trip respective DC generator and alternator off-line.
- Trip respective engine ignitors off-line.
- Trip respective thrust reverser control unit off-line and prevent the thrust reverser isolation valve from opening.

Illumination of the EXTINGUISHER #1/#2 ARMED light(s) indicates that the fire extinguishing system is armed and the squibs are good. Depressing an illuminated EXTINGUISHER #1 ARMED light will discharge the contents of the first extinguisher bottle into the associated nacelle. Depressing the EXTINGUISHER #2 ARMED light will discharge the contents of the second bottle. Either or both EXTINGUISHER #1/#2 ARMED lights may be depressed to extinguish the fire. Should the first container control the fire, the other container is available to either engine.

## **FIRE EXTINGUISHER DISCHARGE INDICATORS**

Two disk-type indicators are flush-mounted in the fuselage under the right engine pylon. If the contents of either or both containers have been discharged into the engine nacelles, the yellow disk will be ruptured. If the contents of either or both containers have been discharged overboard as the result of an overheat condition causing excessive pressure within the containers, the red disk will be ruptured. If both disks are intact, the system has not been discharged.



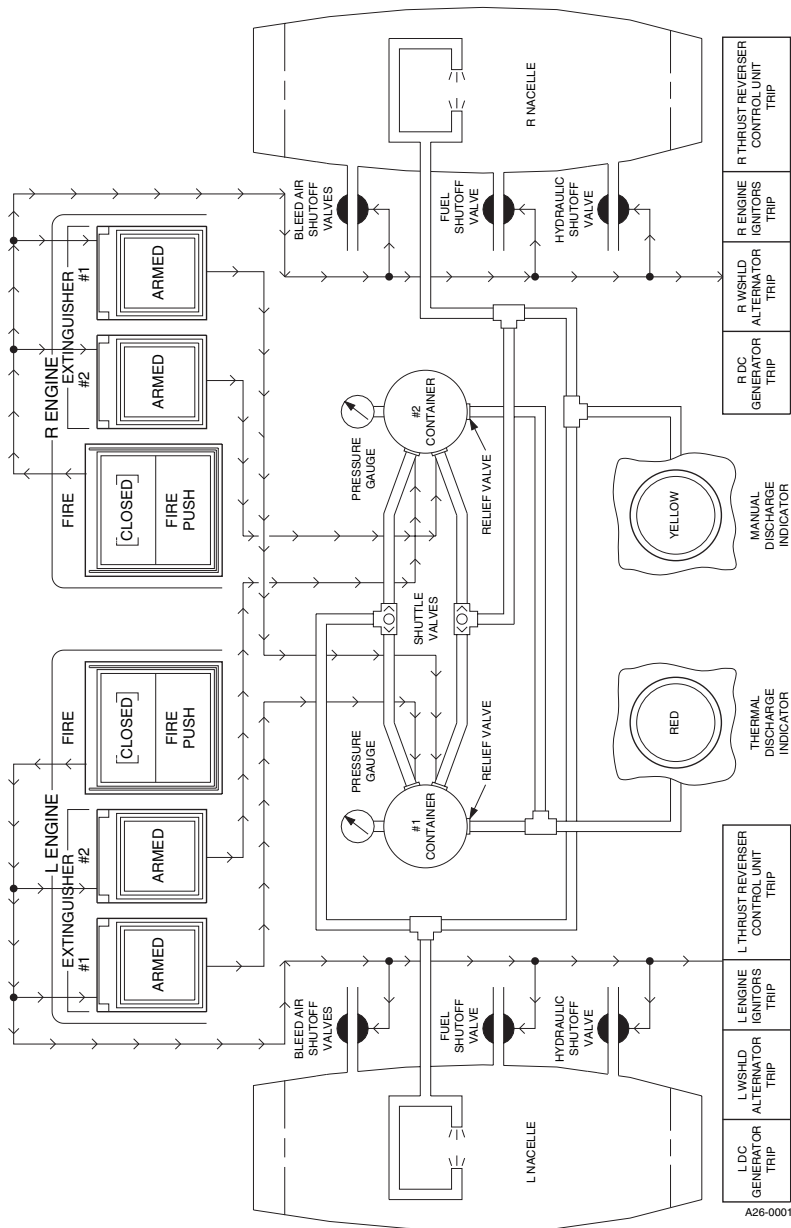

**FIRE EXTINGUISHING SYSTEM**  
**Figure 2-3**

## **THRUST REVERSERS**

Each engine is equipped with an independent, electrically controlled, hydraulically actuated, clamshell-type thrust reverser. The thrust reverser system consists of a thrust reverser control unit, an engine nacelle afterbody on each engine, a piggy-back thrust reverser lever on each main thrust lever, associated hydraulic plumbing, and associated electrical wiring.

The thrust reverser control unit integrates all deploy, stow, and indication functions of the thrust reverser system. Input signals indicating the status of each of these functions are analyzed by the thrust reverser control unit. Different combinations of these signals will generate the applicable output command from the thrust reverser control unit.

Each nacelle afterbody consists of an upper and lower blocker door, an inboard and outboard primary deploy/stow actuator, unlatch actuator, unlatch switch, unlock switch, full deploy switch, and a throttle retard mechanism. Hydraulic power for thrust reverser operation is supplied by the aircraft hydraulic system. A selector valve for each thrust reverser is installed in the tailcone. The selector valves control hydraulic flow to the associated system actuators in response to electrical inputs from the associated thrust reverser lever and position switches via the thrust reverser control unit.

The thrust reverser levers and the system circuit breakers are the only controls used by the crew to operate the system. Electrical power for thrust reverser control and indication circuits is 28-vdc supplied by the L and R ESS buses through the L and R REVERSER circuit breakers. The L REVERSER circuit breakers located in the ENGINE group of the pilot's circuit breaker panel include the 5-amp DEPLOY, the 3-amp ANN, and the 3-amp STOW. The R REVERSER circuit breakers located within the ENGINE group of the copilot's circuit breaker panel also include a 5-amp DEPLOY, a 3-amp ANN, and a 3-amp STOW.

In order to arm the thrust reversers, both main gear weight-on-wheels switches must be in the ground mode (aircraft weight on the main gear) and the thrust levers must be in the IDLE position. When fully armed (reverser system relays and switches are properly sequenced), the associated isolation valve is open and the system is ready for deploy/stow commands by operation of the thrust reverser levers.

The clam-shell type blocker doors are held in the stowed position by latch hooks. The latch hooks are hinged to the unlatch actuator, and are rotated away from the blocker doors for thrust reverser deployment. When the deploy cycle is initiated, hydraulic pressure is applied to the stow side of the primary actuators which move the doors into an

overstowed condition. Overstowing the thrust reversers allows the unlatch actuators to rotate the latch hooks. As the latch hooks begin to rotate, the unlock switch signals the thrust reverser control unit of the unlocked condition. As the latch hooks clear the blocker door receptacles, an unlatch switch signals the thrust reverser control unit that the blocker doors are unlatched. After the latch hooks are unlatched, hydraulic pressure is applied to the deploy side of the primary actuators which push the doors open.

Stow is initiated automatically whenever an unlock condition is detected and the thrust reverser lever is forward of the thrust reverser deploy detent. This occurs during the normal stow cycle and also to correct an abnormal condition in flight. During autostow, hydraulic pressure is applied to the stow side of the primary actuators and the blocker doors move towards the overstay position. As the doors reach overstay, the spring-loaded latches close. When the latches close, the unlock switches are deactivated. The selector valve then releases stow pressure on the primary stow/deploy actuator. Exhaust gas pressure and springs return the doors to the normal stowed position.

An automatic throttle retard mechanism is installed on each thrust reverser to ensure that thrust reverser stow and deploy does not occur with an engine thrust setting above idle. The throttle retard mechanism consists of an actuator, crank, and lever. Whenever hydraulic stow pressure is applied to the thrust reverser actuators, the throttle retard mechanism will position thrust lever to the IDLE position. When hydraulic stow pressure is removed, the mechanism will return to a neutral position and release retard pressure to the thrust lever.

## **THRUST REVERSER LEVERS**

A thrust reverser control lever for each thrust reverser is mounted piggy-back fashion on each main thrust lever. The thrust reverser levers are inoperable and cannot be moved unless the associated main thrust levers are at the IDLE stop. Similarly, the main thrust levers cannot be moved from the IDLE position until the associated thrust reverser lever is in the stow (full down) position. When fully armed, a thrust reverser may be independently deployed by lifting the corresponding thrust reverser lever to the first (idle/deploy) stop. A throttle release will activate and the thrust reverser lever may be pulled beyond the idle/deploy stop to increase reverse thrust. If both thrust reversers are deployed, a detent limits thrust reverser lever travel to approximately MCR.

The thrust reverser is stowed by first returning the thrust reverser lever to the idle/deploy stop and then moving the lever to the stow (full down) position at engine idle speed.

**THRUST REVERSER INDICATIONS**

Thrust reverser control is automatic and status indications are displayed on the EICAS and CWP. The following EICAS illuminations are specific to the thrust reversers:

<b>EICAS</b>	<b>Color</b>	<b>Description</b>
DEP (EI)	Red	Uncommanded deployment of the associated (L or R) thrust reverser.
DEP (EI)	Green	Normal thrust reverser deployment on the ground.
REV (EI)	Amber	The associated (L or R) thrust reverser system is armed in flight or on the ground with thrust lever greater than MCR.
REV (EI)	White	The associated (L or R) thrust reverser system is armed on the ground with thrust lever in IDLE.
REV AUTOSTOW	White	The associated (L or R) thrust reverser autostow function is activated.
REV FAULT	White	A fault is detected in the associated (L or R) thrust reverser system.
UNL (EI)	Red	The associated thrust reverser system is not armed, but an unlock condition is detected.
UNL (EI)	Amber	On the ground, the thrust reverser is in transition between stow and deploy. It will temporarily illuminate during normal thrust reverser deployment. If illumination continues for more than several seconds, an abnormal condition exists and the master caution is tripped.

During normal thrust reverser deployment the following illuminations will occur:

1. REV white EI.
2. UNL amber EI.
3. DEP green EI.

During normal thrust reverser stowage the above illuminations will be reversed.

The CWP contains red L and R REV UNSAFE lights which will illuminate in conjunction with a UNL or DEP red EI above the N1 indicator. Whenever this illumination occurs, a continuous "LEFT" or "RIGHT REVERSER UNSAFE" voice message will sound. This voice message can be silenced by depressing the mute switch located on the right thrust lever or depressing the master CAUT/WARN light.

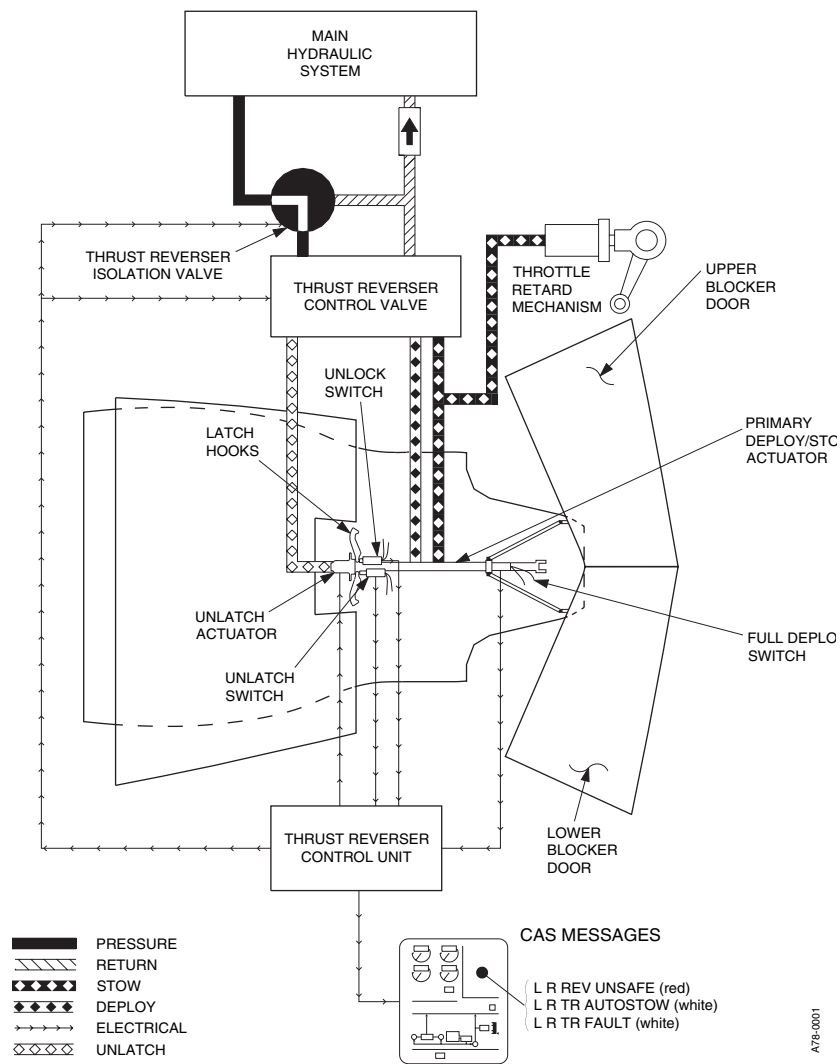

A78-0001

**THRUST REVERSER SYSTEM SCHEMATIC**  
**Figure 2-4**

## **AIRCRAFT FUEL SYSTEM**

The aircraft fuel system consists of two wing tanks, a fuselage tank, a fuel flow indicating system, a fuel quantity indicating system, a fuel transfer system, a fuel vent/expansion system and a single-point pressure refueling system.

### **WING TANKS**

The wing is divided into two separate fuel-tight compartments which serve as fuel tanks. Each tank extends from the wing root to a point just short of the winglets, thus providing a separate fuel supply for each engine. A crossflow shutoff valve is installed to permit fuel transfer between wing tanks. Wing tank over-pressurization is prevented by vent/expansion lines between the wing tanks and fuselage tank. This allows access to the main fuel vent/expansion system of the fuselage tank. Flapper-type check valves, located in the various wing ribs, allowing free fuel flow inboard but restricted outboard fuel flow. A main jet pump is mounted in each wing tank near the center bulkhead to supply fuel under pressure to the respective engine fuel system. A standby pump also located at this location can be utilized as a back-up for the main jet pump, or be used to transfer fuel from wing tank to wing tank or defuel the aircraft. Three scavenge jet pumps, located throughout each wing tank, are used to transfer fuel to the inboard collector bay containing the main fuel jet pump. A fourth scavenge jet pump, located in the forward end of the collector tank, is used to transfer fuel to the inlet of the main fuel pumps. A fifth scavenge jet pump, located in the outlet of the fuselage to wing transfer line, is used to assist gravity in the transfer of fuel from fuselage to wing during normal aircraft operation. The wings are filled from the fuselage tank through the refueling manifold or the gravity filler port.

### **FUSELAGE TANK**

The fuselage tank consists of a single bladder-type cell located in the aft fuselage. The tank is equipped with a pressure refueling adapter, a gravity filler port, a fuel probe, a refueling manifold/nozzle, and a fuel vent/expansion system with an auxiliary vacuum/pressure relief valve. The tank allows the entire fuel system to be serviced through a pressure refueling adapter located on the right side of the aircraft below the engine pylon, or a gravity filler port located on the right side of the aircraft above the engine pylon. The gravity transfer system is boosted by motive flow through the refueling manifold/nozzle during refueling operations. Fuel will flow to both wing tanks through two transfer lines.

## FUEL FLOW INDICATING SYSTEM

The fuel flow indicating system consists of a Dual Fuel Flow Converter (DFFC) and a fuel flow transmitter located in the main fuel line of each engine. There is no fuel flow transmitter for the APU. The fuel flow transmitters sense flow rate and fuel temperature, and provide these parameters to the DFFC. The DFFC processes these signals and sends a flow rate, along with the total fuel burned (APU fuel not included), to a Data Acquisition Unit (DAU). The DAU transfers the information to the flight management system for fuel monitoring and to EICAS for flight deck display to show Fuel Flow (FF) left and right engine, and total fuel used (refer to Figure 2-5 for the EICAS Fuel Page).

A TOTALIZER RESET switch, located within the FUEL group of the pedestal control panel, will reset the fuel burned information held in the DFFC's nonvolatile memory after fuel servicing. The fuel used can be zeroed out by depressing and holding the TOTALIZER RESET button for a minimum of two seconds.

The DFFC is powered by 28-vdc supplied by the 1-amp L and R FUEL FLOW circuit breakers located within the ENGINE groups of the pilot's and copilot's circuit breaker panels respectively.

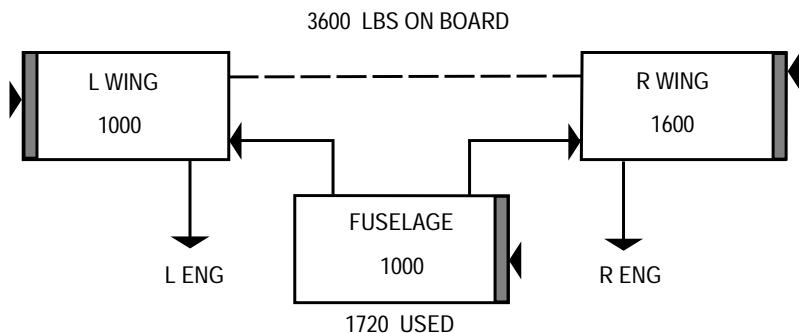

**FUEL PAGE**  
**Figure 2-5**

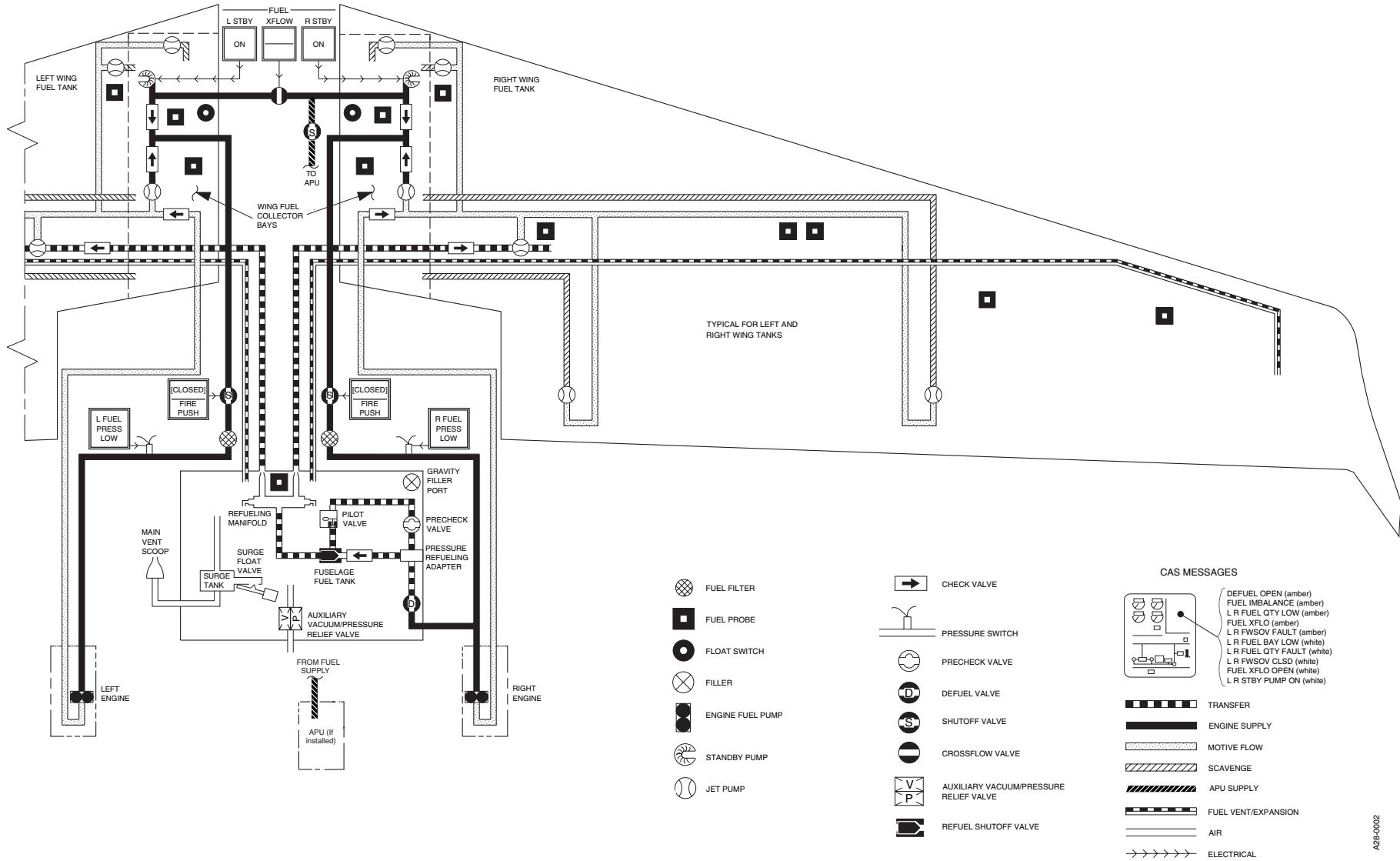

A28-002

**FUEL SYSTEM SCHEMATIC**  
**Figure 2-6**





**STBY SWITCHES**

The L and R STBY switches, within the FUEL group of the aft pedestal, manually control the operation of the electric standby pumps. These momentary switches normally remain off. In the event of a main jet pump failure or during fuel crossflow, the L and R STBY switches must be manually selected to ON by the flight crew. The standby pumps are automatically energized during engine start (begins when the L or R START switch is depressed, and stops at 50% N<sub>2</sub>). The right standby pump is automatically energized during APU start and run. When the standby pumps are operating, the L and/or R STBY switches will illuminate ON.

The standby pumps operate on 28-vdc supplied through the 15-amp L and R STBY PUMP PWR circuit breakers within the FUEL groups of the pilot's and copilot's circuit breaker panels respectively. The automatic and manual pump controls are powered by 28-vdc through the 3-amp L and R STBY PUMP CTRL circuit breakers located within the FUEL groups of the pilot's and copilot's circuit breaker panels respectively.

The following CAS illuminations are specific to the standby fuel pumps:

<b>CAS</b>	<b>Color</b>	<b>Description</b>
FUEL PRESS LOW	Red	Fuel pressure is low at the associated (L or R) engine's fuel pump inlet.
STBY PUMP ON	White	The associated (L or R) standby fuel pump is receiving electrical power.

**XFLOW SWITCH AND CROSSFLOW SHUTOFF VALVE**

The XFLOW switch, within the FUEL group of the aft pedestal, controls the crossflow shutoff valve. The valve is normally in the closed position. Depressing the XFLOW switch illuminates a white bar and power is applied to open the motorized crossflow shutoff valve allowing fuel to flow between the wing tanks.

To balance wing fuel, the XFLOW switch should be set to open (white bar illuminated) and the heavy side L or R STBY switch set to ON. The standby pump will continue to operate until the L or R STBY switch is deselected. The crossflow shutoff valve allows all usable fuel aboard the aircraft to be available to either engine. The switch should not be selected except when correcting an out-of-balance condition.

The crossflow shutoff valve operates on 28-vdc supplied from the rear hot bus through the 5-amp XFLOW VALVE CTRL circuit breaker located within the FUEL group of the copilot's circuit breaker panel. Loss of power to the crossflow shutoff valve causes the valve to remain in its last commanded position.

The following CAS illuminations are specific to the XFLOW switch and crossflow shutoff valve:

<b>CAS</b>	<b>Color</b>	<b>Description</b>
FUEL PRESS LOW	Red	Fuel pressure is low at the associated (L or R) engine's fuel pump inlet.
FUEL XFLO	Amber	The fuel crossflow valve is not fully opened or closed as commanded.
FUEL XFLO OPEN	White	The fuel crossflow valve is open.
STBY PUMP ON	White	The associated (L or R) standby fuel pump is receiving electrical power.

## FUEL INDICATING SYSTEM

The fuel indicating system consists of a refueling control panel, a fuel quantity signal conditioner, 16 wing tank fuel quantity probes (8 each wing), and a fuselage tank fuel quantity probe. The system provides fuel quantity accuracy which indicates zero at zero fuel and is corrected for pitch and roll through the AHRS system.

Power for the fuel indicating system is 28-vdc supplied through the 1-amp L and R QTY circuit breakers located within the FUEL groups of the pilot and copilot circuit breaker panels respectively.

### REFUELING CONTROL PANEL

The refueling control panel is located on the exterior of the aircraft below the right engine pylon. The panel is energized by the FUEL PNL ON/OFF switch. This switch also activates a floodlight when placed in the ON/FLD LT position. This floodlight is installed below the right engine pylon and is energized from the EMER BATT hot bus to allow refueling without accessing the aircraft. The DEFUEL/READY/OFF switch opens the defuel shutoff valve and the crossflow shutoff valve when selected to READY for defueling operations. An amber LED indicator above the READY will illuminate when both valves are open. A green LED indicator below the OFF will illuminate when both valves are closed. A four-digit LED labeled TOTAL FUEL QTY will indicate total usable fuel in LB or KG depending on aircraft configuration.

## FUEL QUANTITY SIGNAL CONDITIONER AND PROBES

The fuel quantity signal conditioner is based on two independently powered left and right wing channels. Each channel receives DC inputs from their respective wing probes. Both channels independently monitor the fuselage probe and receive aircraft pitch information from the AHRS #1 unit. This data significantly increases the accuracy of the fuel indicating system during climb and descent. Each channel monitors the data output of the other for calculating total fuel quantity for transmittal to the DAUs. Although each channel outputs the same fuel quantity information, the DAUs will only read specific information. DAU #1 reads left quantity and total quantity. DAU #2 reads right quantity and fuselage quantity. A weight-on-wheels input allows for separate calculation software to operate "on the ground" or "in the air", making the system more accurate in both environments.

*Aircraft 45-002 thru 45-258, and 45-260:*

A wing fuel imbalance greater than 500 lb (227 kg) with flaps up or greater than 200 lb (91 kg) with flaps greater than 3° will generate the FUEL IMBALANCE amber CAS.

*Aircraft 45-259, 45-261 thru 45-2000:*

A wing fuel imbalance greater than or equal to 200 lb (91 kg) will generate the FUEL IMBALANCE amber CAS.

The fuel quantity signal conditioner software determines low fuel conditions from the filtered fuel quantity. The L or R FUEL QTY LOW amber CAS is generated when fuel quantity is less than 350 pounds.

The following CAS illuminations are specific to the fuel quantity indicating system:

CAS	Color	Description
FUEL IMBALANCE	Amber	A fuel imbalance exists between the left and right wing tanks.
FUEL QTY LOW	Amber	The fuel quantity in the associated (L or R) wing tank is approaching a minimum desired level for flight.
FUEL QTY FAULT	White	<ul style="list-style-type: none"> <li>- <b>When message preceded by L or R:</b> A fault is detected in the associated channel of the fuel quantity indicating system.</li> <li>- <b>When message <u>not</u> preceded by L or R:</b> The fuselage fuel probe is invalid or attitude input from the AHRS to the fuel quantity indicating system is invalid.</li> </ul>

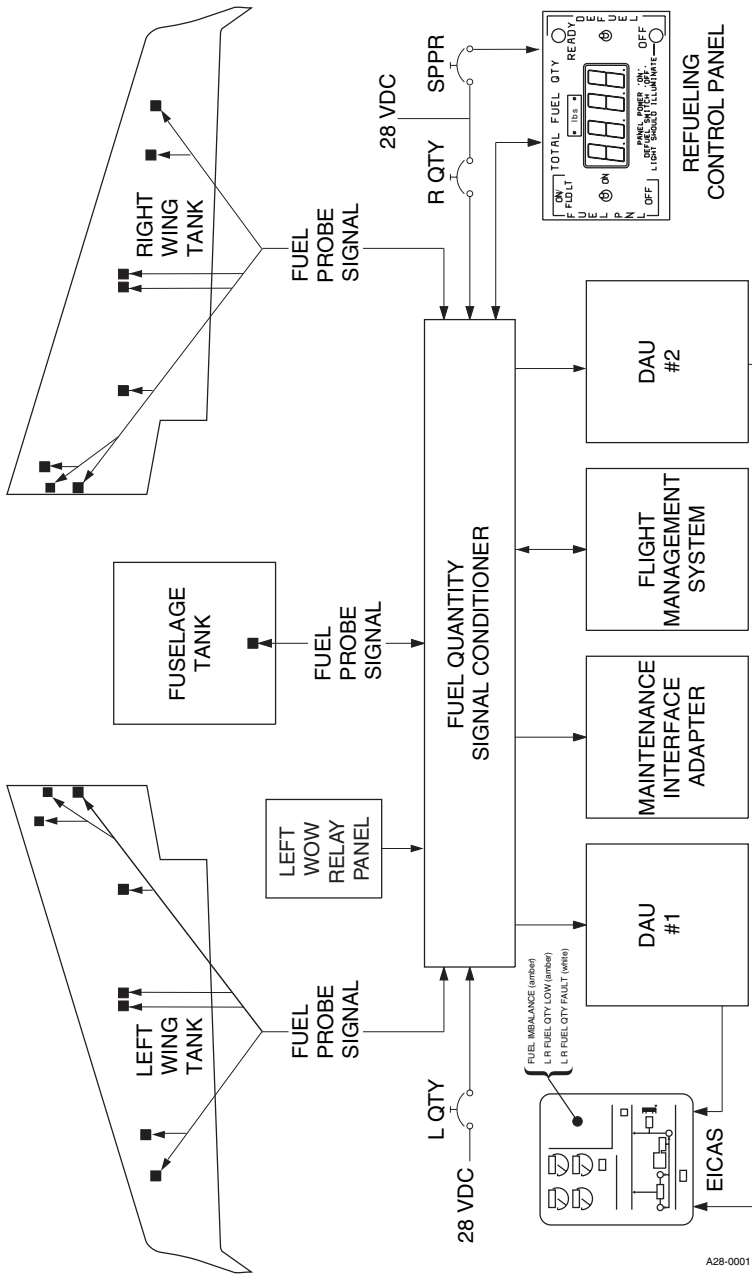

A28-0001

**FUEL INDICATING SYSTEM SCHEMATIC**  
**Figure 2-7**

## **RAM AIR FUEL VENT SYSTEM**

The fuel vent system provides ram air pressure to all interconnected components of the fuel system to ensure positive pressure during all flight conditions. A flush-mounted ram air scoop (NACA vent scoop) located on the left side of the fuselage (forward of the engine) admits pressure to the fuselage tank main vent system. The main vent system pressurizes the wing tanks through the fuel vent/expansion lines. The fuselage fuel vent/expansion lines are each connected to a separate sump that has a moisture drain valve. Overpressurization due to thermal expansion in the wing tanks is relieved through the left and right expansion lines to the fuselage tank. Overpressurization of the fuselage tank is relieved overboard through the NACA vent scoop. The vacuum/pressure relief valve is a backup for the NACA vent scoop.

## **SINGLE-POINT PRESSURE REFUELING (SPPR) SYSTEM**

The Single-Point Pressure Refueling (SPPR) system allows the entire fuel system to be serviced through a SPPR adapter located on the right side of the aircraft below the engine pylon. The SPPR incorporates a precheck system which allows the operator to check the operation of the system shutoff valves before commencing refuel operations. The major system components are the refueling adapter, refueling panel, refuel shutoff valve, pilot valve, precheck valve, and associated plumbing and wiring.

Electrical power to operate the system indicator lights, solenoid valves and fuel quantity signal conditioner is 28-vdc supplied from the EMER BATT hot bus through the PWR ON switch on the refuel control panel.

The refuel shutoff valve is controlled by the pilot valve located at the high point in the fuselage tank. When refueling pressure is applied to the system through the pressure refueling adapter, pressurized fuel is applied to the refuel shutoff valve. This pressure is applied to both sides of the valve poppet. If the pilot valve is open, some of the pressure acting to hold the valve closed will be vented through the pilot valve and the pressure acting to unseat the poppet will drive the valve open against the spring tension. When the tank fills, the pilot valve will close, fuel pressure on both sides of the refuel shutoff valve poppet will equalize, and spring tension will drive the valve closed. If the refuel shutoff valve malfunctions, fuel will vent out of the NACA vent scoop to prevent overpressurization of the fuselage tank.

## PRECHECK VALVE

The precheck valve is used to check operation of the system shutoff valve before full refueling procedures are commenced. When the precheck valve is set to PRECHECK OPEN and refuel pressure is applied to the refuel adapter, fuel will be admitted to the precheck line. The shutoff valve will open and fuel will flow into the fuselage tank. The fuel in the precheck line will empty into a float basin at the pilot valve. When the basin fills, the pilot valve float will close the pilot valve, which causes the shutoff valve to close, terminating fuel flow. Fuel flow should stop within 20 seconds.

## FUEL ADDITIVES

Refer to Airplane Flight Manual Addendum I Fuel Servicing for recommended concentrations and the proper blending methods of approved fuel additives.

## REFUELING

The aircraft is refueled through a gravity filler cap located on the right side of the fuselage above the engine pylon or through the single-point pressure refueling (SPPR) adapter located on the right side of the fuselage below the engine pylon. A refueling panel access door is located next to the SPPR adapter access door. Refer to Airplane Flight Manual Addendum I Fuel Servicing for a list of approved fuels and refueling procedures.

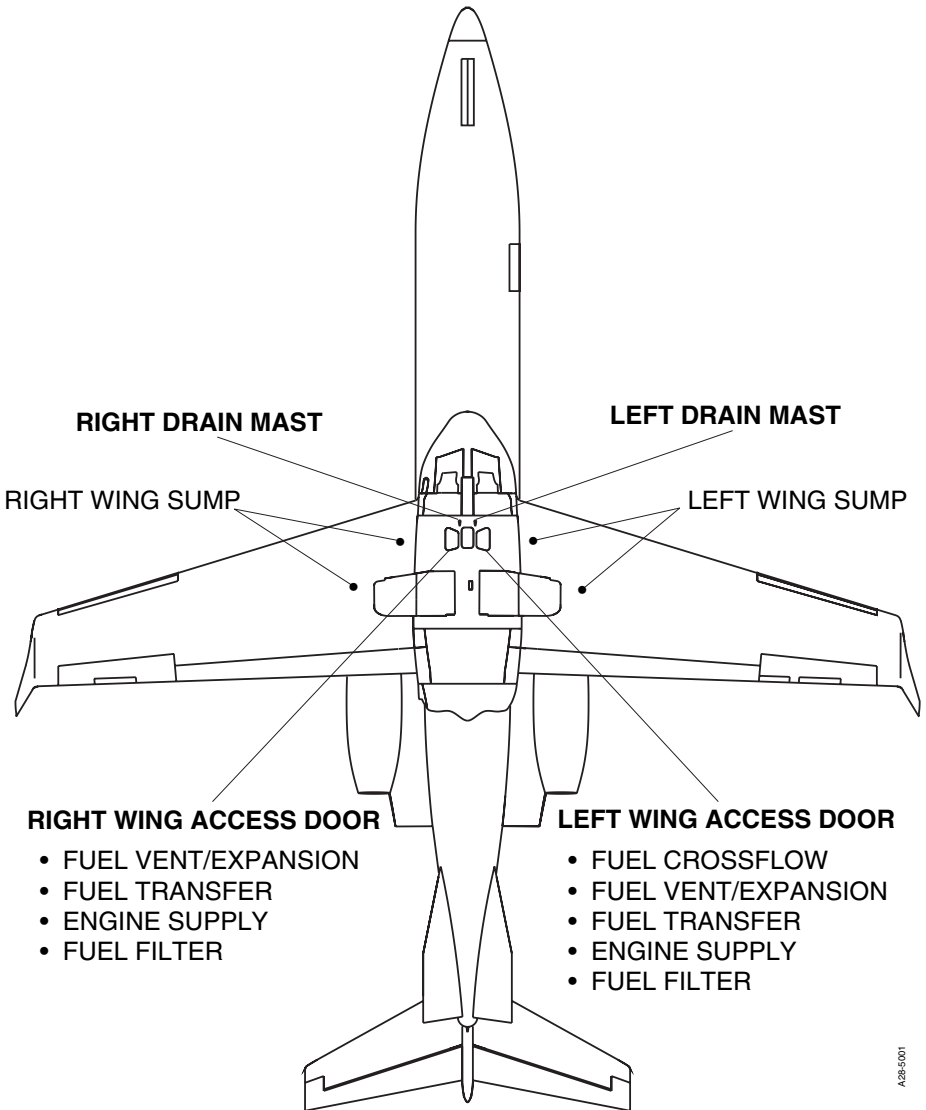



## AUXILIARY POWER UNIT (APU)

The Auxiliary Power Unit (APU), located in a special enclosure above the baggage compartment and tailcone equipment bay, is a self-contained, single-stage gas turbine unit that can be operated continuously up to an ambient temperature of 125° F (52° C). The APU provides pneumatic and electric power for ground operations of the aircraft Environmental Control System and aircraft electrical systems, independent of the aircraft main engines. It is restricted to ground operations only. The starting, acceleration and operation of the engine is controlled by an integral system of automatic and coordinated pneumatic and electromechanical controls.

The APU engine is comprised of three major sections: the accessory section, compressor section and turbine section. Engine power for the auxiliary power unit is developed through compression of ambient air by a single entry, radial, outward-flow, centrifugal compressor. The compressed air, when mixed with fuel and ignited, drives a radial inward-flow turbine rotor.

The APU control panel (located on the center pedestal) contains all of the primary controls to operate the APU. There is also a Maintenance Control Panel in the tailcone equipment bay (primarily for maintenance use). There is an EMER SHUTDOWN switch on this panel.

The engine is controlled and serviced by four systems: the engine fuel system, lubrication system, electrical system and indicating system. Fuel for the APU flows from the right wing fuel tank through the right standby pump and shutoff valve prior to reaching the APU. The APU uses approximately 150 pounds of fuel per hour. The APU should not be started and run in excess of 1 hour with less than 200 pounds in the right wing tank. Running out of fuel in the right wing tank will introduce air in the APU fuel lines which will cavitate the APU and prevent it from restarting immediately. The APU gearbox serves as an oil sump for the APU self-contained lubrication system. The APU Electronic Control Unit (ECU) is a fully automatic system that directs delivery of the correct amount of fuel regardless of ambient conditions and load requirements, as well as properly sequencing control of fuel and ignition during starting. The ECU is also used for trend monitoring (in lieu of a start counter or hour meter, etc.), which is accessed through the RS 232 maintenance port on the Maintenance Control Panel.

A warning horn is installed in the nose avionics bay. The audible alert can be heard out of the nose gear wheel well to alert personnel outside of the aircraft of an APU fire.

There are cooling fans installed in the tailcone equipment bay — one on the tailcone access door, the other on the opposite side of the fuselage. These fans are installed to improve cooling in the tailcone when the APU is operating. They are controlled by a 60° C thermostat located in the area of the tailcone most likely to exceed 70° C. If the temperature falls below 55° C the fans go off. Power for the fans is provided through the APU CMPTR circuit breaker.

If the temperature in the tailcone reaches 70° C, the APU FAN FAIL indicator, in the tailcone, will activate (amber). The indicator is magnetically latched and will remain in the amber position until manually reset using the adjacent RESET switch. The APU FAN FAIL indicator should be checked prior to each start of the APU. If the indicator is activated, fan operation is suspect and maintenance should be obtained as required prior to running the APU. The APU may be operated at ambient temperatures up to 38° C with an amber APU FAN FAIL indication.

The following CAS illuminations are specific to the APU:

<b>CAS</b>	<b>Color</b>	<b>Description</b>
APU FAIL	Amber	- A start inhibit signal has been detected by the APU ECU. or - An APU protective shutdown signal has been detected by the APU ECU. or - The APU aircraft fuel valve is not closed and the APU is not running.

## APU COCKPIT CONTROL PANEL

The APU cockpit control panel, located on the center pedestal, houses the necessary controls for operation and monitoring. APU fire detection/extinguishing controls are also located on the APU cockpit control panel.

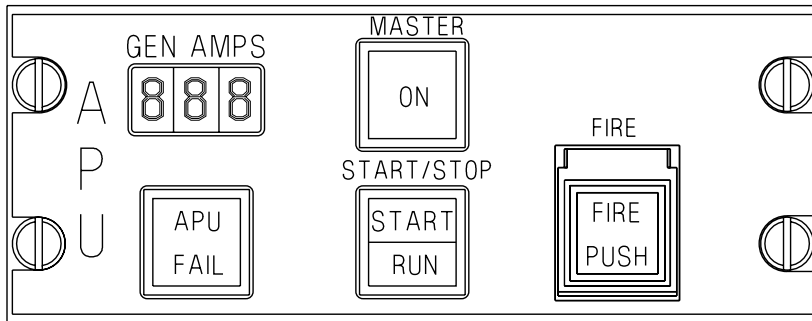

45\_APU\_CPIT\_CTRL

### APU COCKPIT CONTROL PANEL

Figure 2-9

**APU FAIL** — The APU FAIL (amber) indicator shows a failure in the APU control or indication system. The indicator will also show if the aircraft fuel valve is not closed and the APU is not running.

**APU MASTER** — The APU MASTER switch/indicator is an alternate-action push-button switch. When selected ON, the ECU is powered and a bit test is started. If the test fails the APU FAIL indicator will come on.

**APU FIRE** — This switch/indicator is used to show an APU system fire and activate the APU fire extinguishing system. Should there be a fire in the APU, as detected by the fire loop, the FIRE switch/indicator will indicate FIRE PUSH (red), the aircraft Master WARN lights will illuminate, and the APU fire warning horn will sound. The fire detection/extinguishing system will automatically shut down the APU and activate the fire extinguisher within 10 seconds.

Depressing the FIRE switch/indicator will also shut down the APU and discharge the APU fire extinguishing bottle. After shutdown, the start inhibit circuit (within the ECU) is latched, not allowing restart.

#### NOTE

The FIRE switch/indicator is wired directly to the R EMER HOT BUS and will activate the APU fire extinguisher even with the batteries OFF.

**APU GEN AMPS** — The GEN AMPS indicator is a digital display indicating the amperage output of the APU Generator (shows zero during start).

**APU START/STOP** — This switch/indicator is a momentary, two-cell, lighted switch. The top portion is labeled START (white) and is on only while the APU is starting. The lower portion is labeled RUN (green) and is illuminated when the APU is running.

Depressing this switch initiates the APU start sequence. If the APU is running, depressing this switch initiates the APU shutdown sequence.

### **APU MAINTENANCE PANEL**

The APU maintenance panel is located in the tailcone equipment bay. It houses the necessary controls, indicators and interfaces for operation of the APU for maintenance, or to shut down the APU in an emergency.

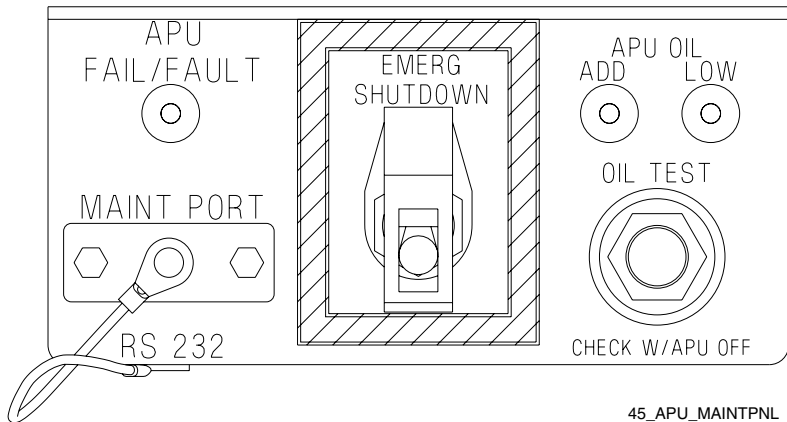

### **APU MAINTENANCE PANEL**

**APU FAIL/FAULT** — The blue APU FAIL/FAULT indicator shows that a fault has been registered by the ECU. The fault will be stored in the ECU.

**APU OIL ADD / LOW** — The APU OIL indicators show whether the APU oil level switch indicates an “ADD” or “LOW” (both amber) condition. These indicators are operative only when the right aircraft battery is on and the OIL TEST switch is held.

**OIL TEST** — The OIL TEST push button switch is used to check the oil level in the APU. Pushing the switch, with the R BATT Switch on, allows the “ADD” or “LOW” indicators to come on as required.

**EMERG SHUTDOWN** — This switch, when toggled, removes power from the APU ECU and causes the APU to shut down. This function is separate from the APU control panel in the cockpit. On the next ECU power up, a loss of DC power fault is logged.

**MAINT PORT**— The RS 232 maintenance port provides the interface between the APU ECU and the field service monitor. The PC and ECU communicate through this port to provide maintenance personnel with fault isolation information stored in the APU ECU.

### **APU FIRE WARNING SYSTEM**

The APU fire detection system consists of a sealed gas line inside the shroud surrounding the APU itself. In the event of a fire external to the APU proper the increase in pressure in the sealed line activates the system:

- The APU FIRE PUSH and aircraft master WARN lights will illuminate, the APU fire warning horn sounds and the APU shuts down.
- Ten seconds after illumination of the APU FIRE PUSH annunciator, the fire bottle will release a charge of Halon into the APU compartment.
- The fire extinguisher may also be activated manually by depressing the APU FIRE switch.

The following CAS illuminations are specific to the APU fire warning system:

<b>CAS</b>	<b>Color</b>	<b>Description</b>
APU FIRE	Red	A fire has been detected in the APU compartment.

### **APU BLEED AIR**

Refer to Section VI, ANTI-ICE & ENVIRONMENTAL, for information on APU bleed air.

### **APU GENERATOR**

Refer to Section IV, ELECTRICAL & LIGHTING, for information on the APU generator.

**OPERATING PROCEDURES**

## APU PRE-START CHECK

This check should be accomplished if the APU is to be started without accomplishing the standard aircraft preflight.

**NOTE** The APU maintenance panel is located in the tailcone. Access is gained through the tailcone access door.

1. L and R BATT Switches — On, simultaneously.
2. EMER BATT Switch — EMER.
3. APU MASTER Switch — ON.
4. Tailcone Interior Check:
  - a. OIL TEST Switch (on the APU maintenance panel) — Select. If the LOW indicator comes on, have oil serviced prior to starting the APU.
  - b. APU FAN FAIL indicator (in the tailcone) — Check. If indicator shows amber, obtain maintenance as required prior to running APU (temperatures above 100° F [38° C]).

**NOTE** APU may be operated at ambient temperatures up to 100° F (38° C) with an amber APU FAN FAIL indication.

- c. APU Fire Bottle Pressure — Check.
5. APU Exhaust — Clear of obstructions.
6. APU Inlet — Clear of obstructions.
7. Check APU firebox drains for indications of oil or fuel leaks.
8. Fuel Quantity (right wing) — Check.
9. PACK Circuit Breaker (pilot's ENVIRONMENTAL group) — Set.
10. APU Circuit Breakers (copilot's APU group) — Set.
11. L and R BLEED Circuit Breakers (pilot's and copilot's ENVIRONMENTAL and ENVIR group) — Set.
12. MAN and AUTO Circuit Breakers (copilot's ENVIR group [TEMP CTRL]) — Set.
13. L and R BLEED Switches — OFF.
14. PACK Switch — OFF.
15. HI FLOW Switch — Off.
16. MANUAL TEMP Switch — Off.
17. COCKPIT and CABIN TEMPERATURE COLD-HOT Knobs — Rotate to the mid (12 o'clock) position.

## APU START UP

To start the APU:

1. L INSTR Lights Switch — On.
2. BCN/STROBE Switch — BCN.
3. APU Fire Detection System — Test:

**CAUTION**

Ensure personnel are clear of the nose wheel well/avionics bay area during the APU fire warning system test. The APU fire warning horn is located in this area.

- a. SYSTEM TEST Switch — Rotate to FIRE DET. Press and hold.
  - b. Verify:
    - The APU FIRE red CAS activates.
    - The Master WARN tone and lights activate.
    - The APU FIRE switch/indicator illuminates.
    - After 13 to 18 seconds the APU fire warning horn will sound.
  - c. SYSTEM TEST Switch — Release.
4. APU START/STOP Switch — Press (momentarily) and release. An automatic start sequence is initiated and the following events will occur:
- The white START light will illuminate.
  - The APU engine start relay receives 28-vdc power from both aircraft batteries.
  - The APU fuel shutoff valve opens. The right fuel standby pump begins operation (an R STBY PUMP ON white CAS is displayed and ON will illuminate on the R STBY PUMP switch/indicator).
  - As the starter is energized, it provides a rotational input to the gear train. The gear train drives the compressor and turbine components, the oil pump and the fuel control unit.
  - When the engine reaches the specified RPM, the ECU permits fuel flow to the fuel nozzle assemblies, and the ignition unit causes the igniter plug to fire and ignite the fuel-air mixture in the combustion chamber.
  - The starter assists acceleration up to the starter cutout speed.

- At approximately 60% RPM, compressor discharge pressure opens the surge control valve, dumping a small percentage of compressor discharge air overboard preventing engine surge.
  - As acceleration continues and engine speed reaches approximately 95% RPM plus 4 seconds, the ECU deactivates ignition.
  - On the START/STOP switch/indicator, the START light goes off and the green RUN light comes on. On the APU GEN switch, on the electrical control panel, the green AVAIL light comes on (a delay of 3 seconds or less between the RUN light and the AVAIL light coming on is not abnormal). An APU AVAILABLE white CAS will be displayed.
5. APU GEN Switch — ON.
  6. APU BLEED Switch — ON.
  7. PACK Switch — On.

## APU SHUTDOWN

To shut down the APU:

1. APU START/STOP Switch — Press (momentarily) and release. An automatic shutdown sequence is initiated. Verify that the green RUN light goes off and R STBY PUMP white CAS goes out.
2. APU MASTER Switch (after 30-second delay) — Off.
3. BCN/STROBE Switch — OFF.
4. EMER BATT Switch — OFF.
5. L and R BATT Switches — OFF.



**APU SHUTDOWN FEATURES (Automatic)**

During APU operation, the ECU monitors engine speed, temperature, oil pressure and electrical surge conditions. The ECU contains circuitry which will automatically remove power from the APU's internal fuel solenoid valve and shut down the APU under the following conditions:

- Overspeed
- Electrical surge in ECU driven circuits
- Low oil pressure
- Over temperature
- Failure of EGT thermocouple
- High oil temperature

**APU CIRCUIT BREAKERS**

All APU circuit breakers are located on the copilot's circuit breaker panel.

<b>CIRCUIT BREAKER</b>	<b>SUPPLIES POWER TO</b>
APU CMPTR	APU Ammeter, APU Electronic Control Unit, APU Fans, APU FIRE PUSH Control, APU Fuel Shutoff Valve, APU Maintenance Control Panel, APU MASTER Switch, Generator Reset Control
APU FIRE DET	APU Fire Detection Circuit
APU FIRE EXT	APU Fire Bottle
APU GEN	APU Generator Control Unit