

Table of Contents

Introduction	19-1
10th-Stage Bleed Air	19-2
Description	19-2
Components and Operation	19-3
10th-Stage Bleed Air Manifold	19-3
Engine 10th-Stage Bleed Air Valves	19-3
APU Load Control Valve (LCV)	19-4
External Ground Air Connector	19-4
14th-Stage Bleed Air	19-5
Description	19-5
Components and Operation	19-6
14th-Stage Bleed Air Manifold	19-6
Engine 14th-Stage Bleed Air Valves	19-6
Bleed Air Leak Detection System	19-7
Description	19-7
Components and Operation	19-8
Bleed Leak Detection	19-8
Sensing Elements	19-8
Thermal Switches	19-8
Bleed Air Leak Detection Units	19-8
DUCT MON Test	19-9
Controls and Indicators	19-11
BLEED AIR Panel	19-11
EICAS STATUS Page	19-12
EICAS Messages	19-12

Page Intentionally Left Blank

List of Figures

Graphic Title	Figure
Pneumatic Schematic	19-1
10th-Stage Bleed Air Schematic	19-2
14th-Stage Bleed Air Schematic	19-3
Bleed Air Leak Detection Sensing Elements and Thermal Switches	19-4
Bleed Air Leak Detection System Capabilities	19-5
BLEED AIR Panel	19-6
EICAS STATUS Page - Bleed Pressure Readouts	19-7

Page Intentionally Left Blank

Introduction

The pneumatic system consists of two separate bleed air systems; 10th-stage and 14th-stage bleed air. The 10th-stage bleed air is supplied from the engines, the APU or an external air source. The 14th-stage bleed air is supplied from the engines.

The pneumatics system also includes a bleed air leak detection system that warns the flight crew of possible duct ruptures.

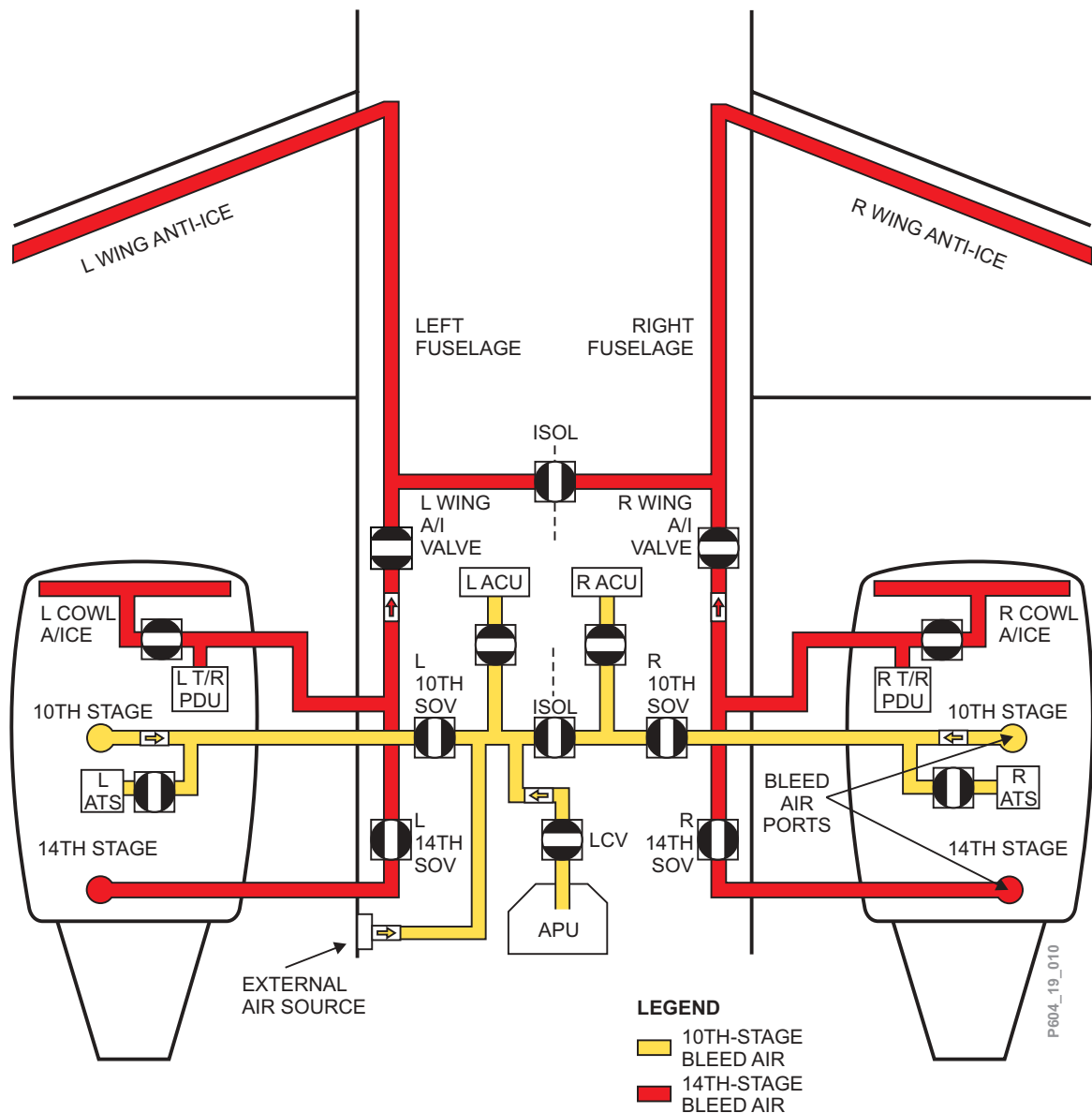

Pneumatic Schematic

Figure 19-1

10th-Stage Bleed Air

Description

The 10th-stage bleed air is supplied from the left and right engine compressor's 10th stage, the APU or an external air source. The bleed air is distributed to the various systems by the 10th-stage bleed air manifold.

Bleed air from the 10th-stage manifold is used for:

- engine starting
- air conditioning and pressurization

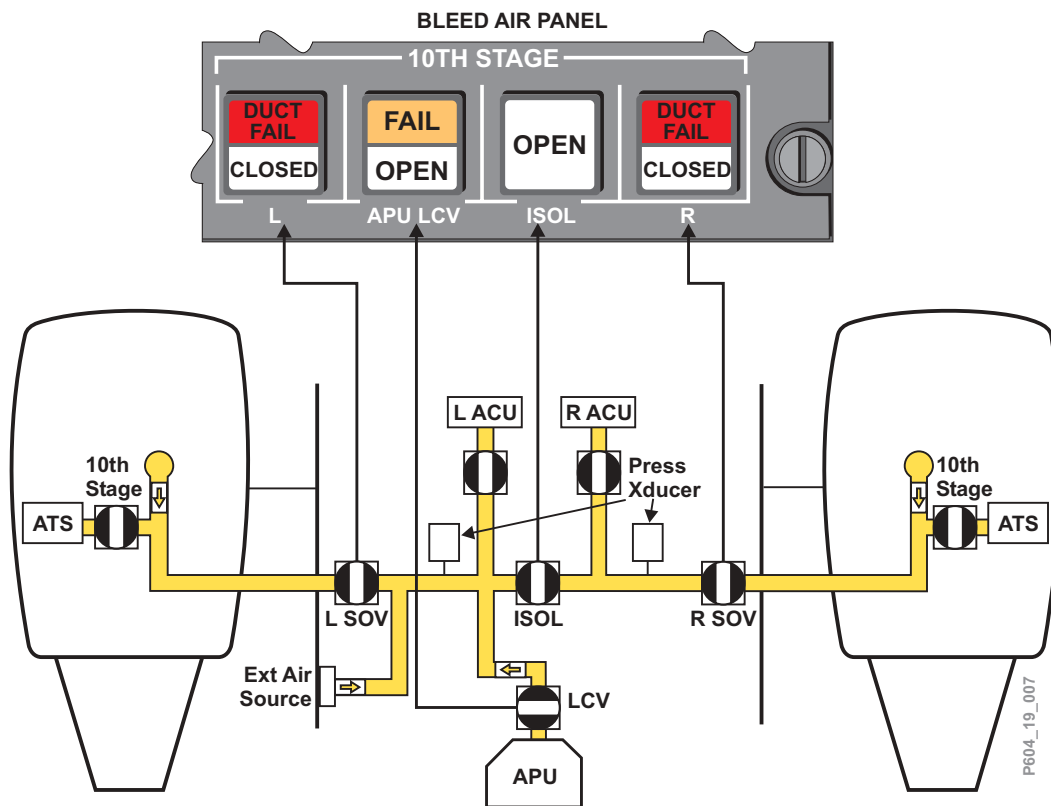

10th-Stage Bleed Air Schematic

Figure 19-2

Components and Operation

10th-Stage Bleed Air Manifold

The 10th-stage bleed air manifold is located in the aft equipment bay. An isolation valve divides the 10th stage into the left and right manifolds. With the isolation valve closed, the left manifold may be pressurized from external air, APU or left engine bleed air. The right engine bleed air normally pressurizes the right manifold.

One-way check valves are installed on the engine in the 10th-stage bleed ducts. The valves prevent the reverse flow of manifold air into the engines. Similar valves are also used for the APU and the external ground air connector.

Pressure readings for the manifold are derived from two pressure transducers, one for the left manifold and one for the right manifold. The pressure readings for the left and right 10th-stage manifold are displayed on the EICAS Status page.

Isolation Valve

The isolation valve is located in the aft equipment bay and is used to isolate the left and the right manifold. Opening the isolation valve allows air from any of the sources to be supplied to the left or right manifold as required. The 10th-stage isolation valve is an electrically controlled, pneumatically operated valve, which either fully opens or fully closes. The isolation valve is spring-loaded closed when no 10th-stage bleed air is available or when electrical control power is lost.

The isolation valve is manually commanded open or closed by the 10TH STAGE ISOL switch/light located on the BLEED AIR Panel. The valve may also be automatically commanded open or closed by the following conditions:

- open; during engine starts (starter engagement)
- closed; when a pack overpressure occurs

Valve status is indicated by the switch/light OPEN annunciation.

Engine 10th-Stage Bleed Air Valves

The 10th-stage bleed air valves are located in the aft equipment bay and control the supply of 10th-stage bleed air to the engines for starting, and from the engines for bleed air supply. 10th-stage bleed air valve operation is similar to the isolation valve. The valves are manually commanded open or closed by the L (R) 10TH STAGE switch/lights located on the BLEED AIR Panel. The valves may also be automatically commanded open or closed by the following conditions:

- open: during engine starts (starter engagement)
- closed: when the associated ENG FIRE PUSH switch/light is pressed
- closed: when a pack overpressure occurs

PNEUMATIC SYSTEM

Valve status is indicated by the respective switch/light CLOSED annunciation (see Figure 19-2). Bleed air temperatures and pressures from the engine compressor 10th-stage are unregulated and therefore dependent on engine power settings. Temperatures and pressures can reach 700°F (370°C) and 170 psi (1172 kPa) at full thrust.

APU Load Control Valve (LCV)

The APU load control valve (LCV) controls APU bleed air supply to the 10th-stage manifold. The LCV is an electrically controlled, pneumatically operated valve which either fully opens or closes.

The valve is manually controlled by the APU LCV switch/light located on the BLEED AIR Panel. When the APU LCV switch/light is pressed the valve opens, which allows APU bleed air to enter the left bleed air manifold. The APU LCV is automatically commanded closed by the following conditions:

- excessive APU EGT
- APU LCV interlock protection

Valve status is indicated by the switch/light OPEN annunciation (see Figure 19-2). APU bleed air temperature and pressure can reach 500°F (260°C) and 50 psi (345 kPa).

APU Load Control Valve Interlock Protection

A check valve installed in the APU bleed air duct prevents manifold pressure from entering the APU compressor. The APU LCV interlock provides a second level of protection, preventing manifold pressure from entering the APU by interlocking the APU LCV with the 10th-stage bleed air switches.

The APU Electronic Control Unit (ECU) monitors the switch positions of the LCV, 10th-stage isolation valve, and left and right 10th-stage bleed switches. The APU LCV will automatically close or be prevented from opening whenever the following switch conditions exist:

- L 10th-stage bleed switch/light is pressed open; or
- both R 10th-stage bleed switch/light and the ISOL switch/light are pressed open

External Ground Air Connector

An external ground air connector is located on the aft fuselage below the left engine. Ground air may be supplied to the left manifold of the 10th-stage bleed air-system when a ground air source is attached to the external ground air connector.

14th-Stage Bleed Air

Description

The bleed air for the 14th-stage manifold is taken from a single port on each engine compressor's 14th stage. The air is distributed through the 14th-stage bleed air manifold.

The 14th-stage bleed air is used for:

- wing anti-ice
- cowl anti-ice
- thrust reversers

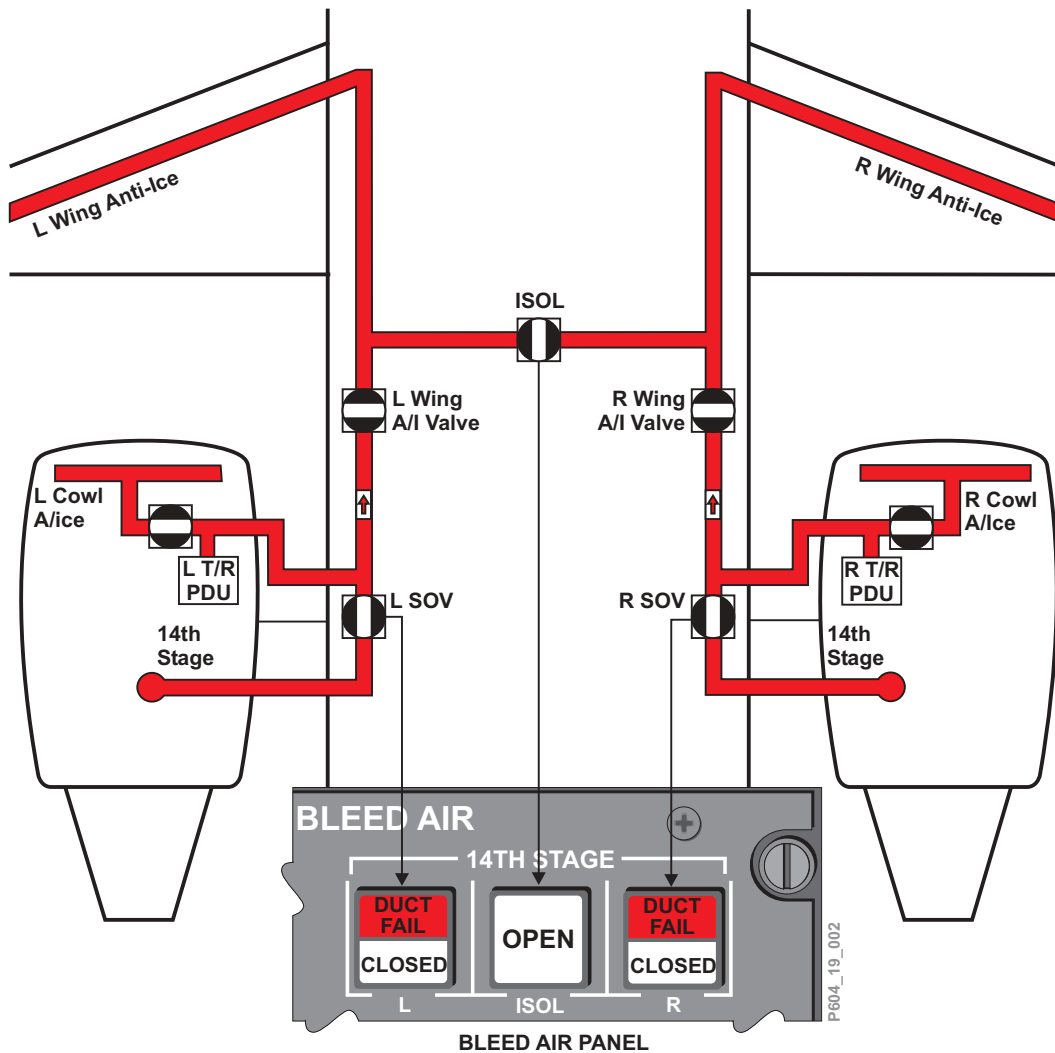

14th-Stage Bleed Air Schematic

Figure 19-3

Components and Operation

14th-Stage Bleed Air Manifold

The 14th-stage bleed air manifold is located in the aft equipment bay. The left engine pressurizes the left manifold and the right engine pressurizes the right manifold. 14th-stage bleed air can only be supplied by an operating engine. Manifold check valves are installed to prevent reverse flow of 14th-stage air to an operating engine.

14th-Stage Isolation Valve

The isolation valve is located in the aft equipment bay and separates the left and right wing anti-ice crossover duct. Refer to Chapter 14 Ice and Rain Protection for a detailed description.

Engine 14th-Stage Bleed Air Valves

The 14th-stage bleed air valves are located in the aft equipment bay and control the supply of 14th-stage bleed air from the engines to the manifold. The 14th stage valves are electrically controlled, pneumatically operated valves, which either fully open or fully close. The bleed air valves are spring-loaded open when no 14th-stage bleed air is available or when electrical control power is lost.

The valves are manually commanded open or closed by the L (R) 14TH STAGE switch/lights, located on the BLEED AIR Panel. The valves are automatically commanded closed when the associated ENG FIRE PUSH switch/light is pressed. However, when bleed air is no longer available after engine N2 spool down, the valve will reopen regardless of the ENG FIRE PUSH switch/light position.

Valve status is indicated by the respective switch/light CLOSED annunciation (see Figure 19-3).

Bleed air temperatures and pressures from the engine compressor 14th-stage are unregulated and therefore dependent on engine power settings. Temperatures and pressures can reach 950°F (510°C) and 215 psi (1482 kPa) at full thrust.

Bleed Air Leak Detection System

Description

The bleed air leak detection system monitors the pneumatic ducting downstream of the 10th-stage and 14th-stage bleed air shutoff valves and wing anti-ice valves along the fuselage, pylon and wing areas.

Bleed air leaks that occur between the engine and the engine bleed air shutoff valves are detected by the engine and jet pipe/pylon overhear detection system. Refer to Chapter 9 Fire Protection.

To detect bleed air leaks, the 10th-stage and 14th-stage bleed air leak detection system uses sensing elements (loops) for bleed air ducting in the aft equipment bay, the portion of the cowl anti-ice ducting which passes through the engine pylon, and for the wing anti-ice ducting passing through the fuselage.

Thermal switches detect bleed air leaks in the leading edge portion of the wing anti-ice ducting.

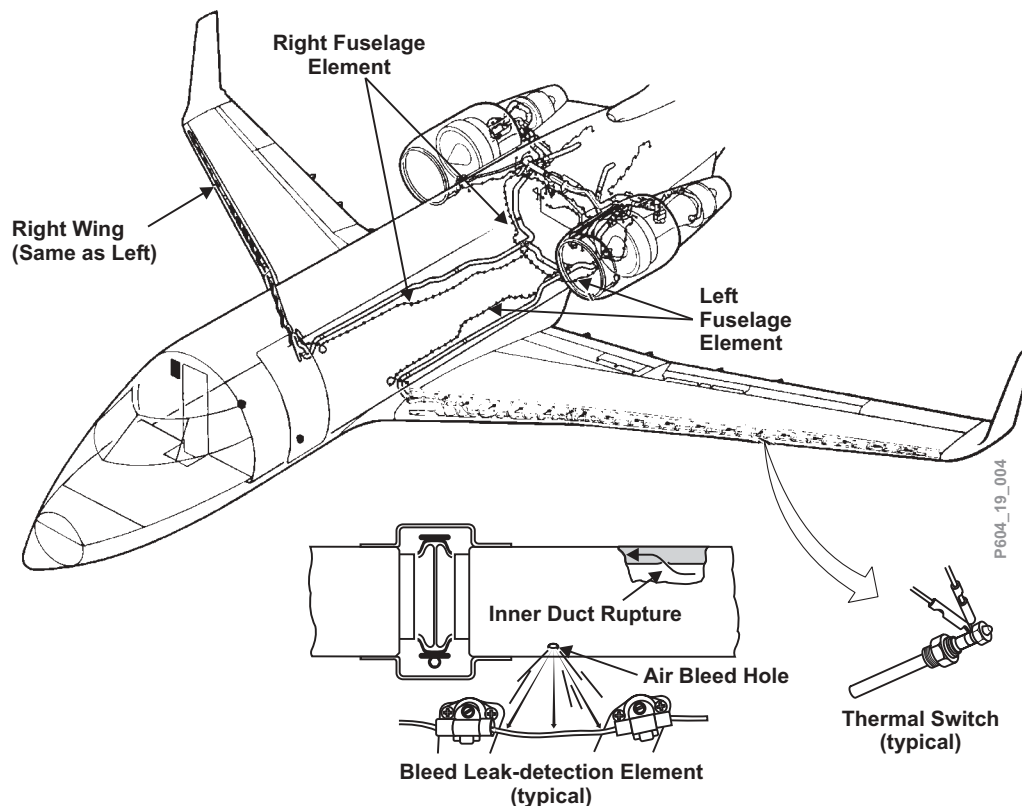

Bleed Air Leak Detection Sensing Elements and Thermal Switches

Figure 19-4

Components and Operation

Bleed Leak Detection

The bleed air ducts are constructed of stainless steel, insulated, and encased by a protective outer cover. A series of holes are drilled at designated locations in the outer cover and sensing elements are installed adjacent to these holes. If a bleed air duct leak develops, these holes direct the escaping hot air toward the leak detection sensing elements.

Sensing Elements

The bleed air leak detection sensing elements operate in a similar manner to the sensing elements used in the engine fire detection system.

The 10th-stage manifold uses a dual-loop sensing system. On a dual-loop system, both loops must detect a leak before a duct overheat warning is given.

The 14th-stage bleed air manifold and the center fuselage wing anti-icing ducts are monitored by single-loop systems.

Thermal Switches

Thermal switches are used in the leading edges of the wings to detect uncontrolled leakage of the anti-icing piccolo tubes. Should a piccolo tube rupture or a clamp fail, the thermal switch closest to the leak will trigger an overheat warning.

Bleed Air Leak Detection Units

Each sensing element is connected to its respective overheat detection unit which monitors the resistance of its loop. When the resistance decreases to the warning trip point, the bleed air leak detection unit prompts EICAS messages as well as aural and visual warnings to alert the flight crew of an overheat condition.

For the 10th-stage ducts, the overheat warning signal will cause the following warnings to occur:

- L (R) 10TH DUCT warning EICAS message is displayed
- MASTER WARNING switch/lights illuminate flashing
- “BLEED AIR DUCT” aural warning sounds
- respective red DUCT FAIL light on the BLEED AIR Panel illuminates

For the 14th-stage ducts, the overheat warning signal will cause the following warnings to occur:

- L (R) 14TH DUCT warning EICAS message is displayed
- MASTER WARNING switch/lights illuminate flashing
- “BLEED AIR DUCT” aural warning sounds
- respective red DUCT FAIL light on the BLEED AIR Panel illuminates

For the wing leading edge and center fuselage wing anti-icing ducts, the overheat warning signal will cause the following warnings to occur:

- ANTI-ICE DUCT warning EICAS message is displayed
- MASTER WARNING switch/lights illuminate flashing
- “ANTI-ICE DUCT” aural warning sounds

Pressing either MASTER WARNING switch/light can silence the aural warnings. However, the EICAS warning message will remain displayed until the condition is corrected (sensing element or thermal switch temperature drops below the trip level).

Any bleed air leak warning requires flight crew action to manually isolate the failed section.

Unlike the engine fire detection sensing elements, the bleed air leak detection units cannot discriminate between an actual overheat condition and a false warning (shorted loop).

DUCT MON Test

The integrity of the Bleed Air Leak Detection system can be tested via the BLEED AIR Panel. Selecting and holding the DUCT MON selector to TEST verifies all sensing elements’ loop continuity by simulating an overheat condition. In addition to the bleed air duct warnings that occur during the test, successful completion will also cause the DUCT TEST OK advisory EICAS message to be displayed.

The LOOP A and LOOP B positions are used to individually test each left and right 10th-stage loop for a short condition. If the selected loop tests normal, the LOOP A TEST OK or LOOP B TEST OK advisory EICAS message will be displayed. Should any 10th-stage loop be shorted, the applicable bleed air duct warning will occur.

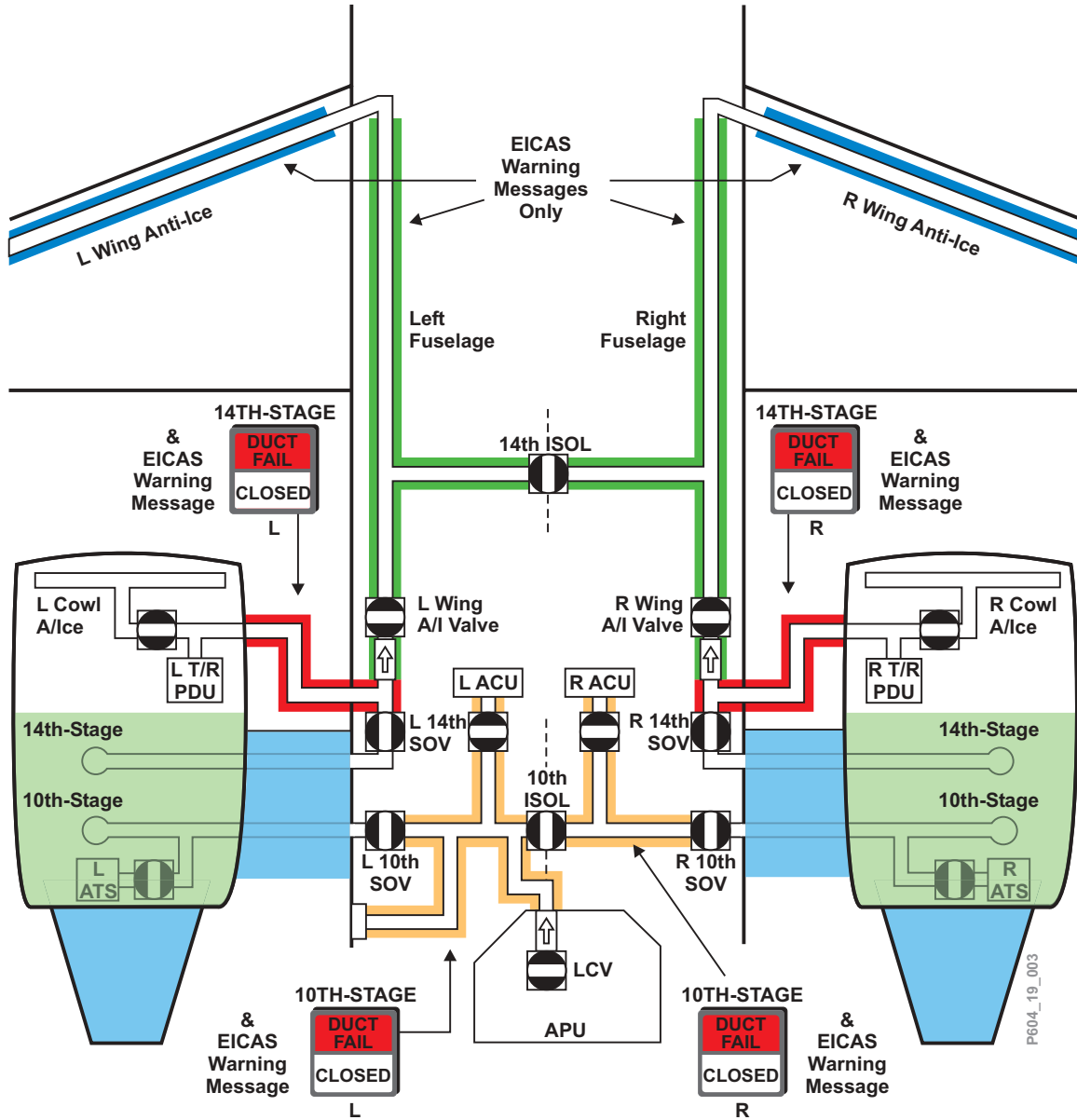

- Engine Fire Detection System (Zone A)
- Jet Pipe / Pylon Overheat Detection System (Zone B)
- Bleed Air Leak Detection System – 10th-Stage
- Bleed Air Leak Detection System – 14th-Stage (pylon)
- Bleed Air Leak Detection System – Anti-Ice (fuselage)
- Bleed Air Leak Detection System – Anti-Ice (wing)

Bleed Air Leak Detection System Capabilities

Figure 19-5

Controls and Indicators

The controls (switch/lights) and the test functions for the pneumatic system are located on the BLEED AIR Panel.

The systems advisory, caution and warning messages are displayed on the EICAS Primary and Status Page. The 10th-stage bleed air pressure readouts are displayed on the Status Page (see Figure 19-7).

BLEED AIR Panel

DUCT MON Selector (Spring-loaded to NORM)
TEST – Tests 10th-stage, 14th-stage and anti-ice sensing elements for continuity by simulating a bleed air leak.
NORM – Normal selector position
LOOP A – Test 10th-stage Loop A sensing elements for short conditions.
LOOP B – Tests 10th-stage Loop B sensing elements for short conditions.

14TH-STAGE L and R Switch/Lights (alternate-action)
Push – Opens or closes respective 14th-stage bleed air shutoff valve.
CLOSED Light Illuminated – Indicates the respective 14th-stage bleed air shutoff valve is closed.
DUCT FAIL Light Illuminated – Indicates a bleed air leak in the respective 14th-stage duct.

14TH-STAGE ISOL Switch/Light
Push – Opens or closes 14th-stage bleed air isolation valve.
OPEN Light Illuminated – Indicates the 14th-stage bleed air isolation valve is open.

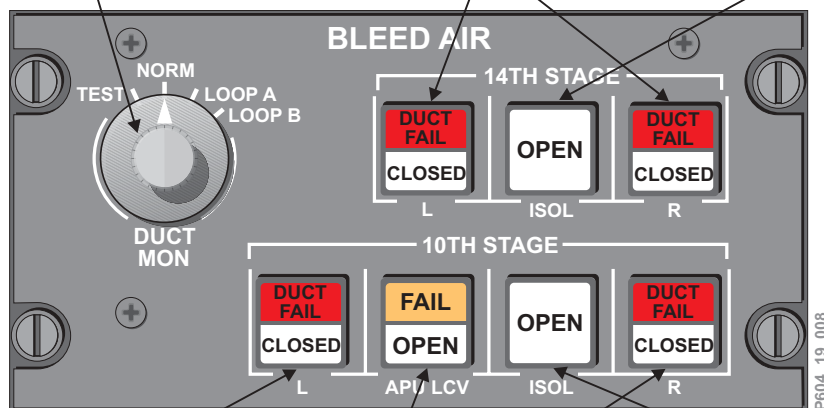

10TH-STAGE L and R Switch/Lights (alternate-action)
Push – Opens or closes respective 10th-stage bleed air shutoff valve.
CLOSED Light Illuminated – Indicates the respective 10th-stage bleed air shutoff valve is closed.
DUCT FAIL Light Illuminated – Indicated a bleed air leak in the respective 10th-stage duct.

APU LCV Switch/Light (alternate-action)
Push – Opens or closes the APU Load Control Valve (LCV).
OPEN Light Illuminated – Indicates the APU LCV is open.
FAIL Light Illuminated – Indicates APU LCV has stuck open when commanded closed by the interlock protection.

10TH-STAGE ISOL Switch/Light (alternate-action)
Push – Opens or closes 14th-stage bleed air isolation valve.
OPEN Light Illuminated – Indicates the 14th-stage bleed air isolation valve is open.

BLEED AIR Panel

Figure 19-6

EICAS STATUS Page

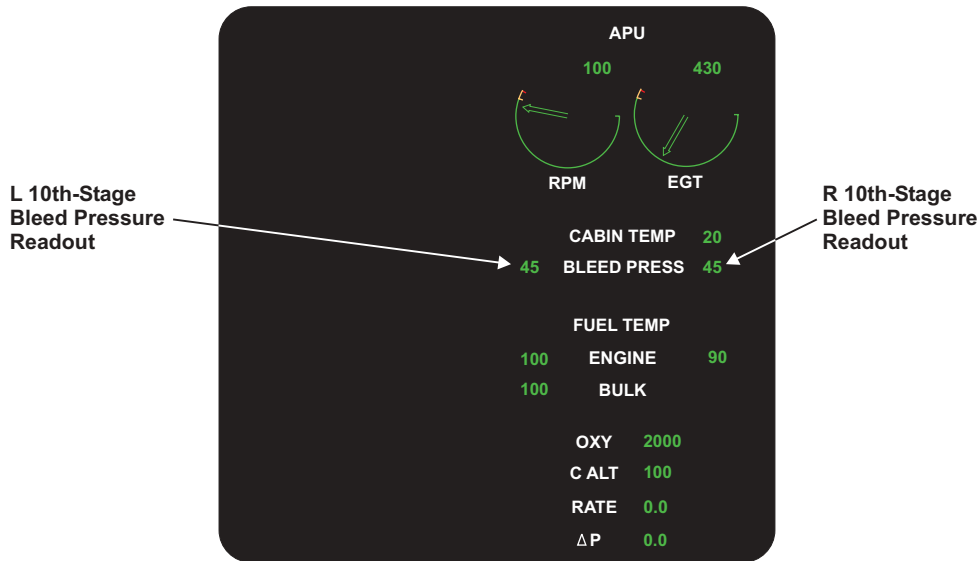

Description	Symbol	Condition
L and R 10th-Stage Bleed Pressure Readout	45	Indicates the pneumatic supply pressure available for operation of air conditioning system or main engine starts
	---	Invalid data

P604_19_009

EICAS STATUS Page - Bleed Pressure Readouts

Figure 19-7

EICAS Messages

MESSAGE	MEANING	AURAL WARNING (IF ANY)
L 10TH DUCT	Bleed air leak in the respective 10th-stage ducting.	"BLEED AIR DUCT"
R 10TH DUCT		
L 14TH DUCT	Bleed air leak in the respective 14th-stage ducting.	"BLEED AIR DUCT"
R 14TH DUCT		
ANTI-ICE DUCT	Bleed air leak in the fuselage or wing anti-ice ducting.	"ANTI-ICE DUCT"
APU LCV FAIL	APU load control valve has failed in the open position with APU LCV interlock activated.	
DUCT TEST OK	Bleed air leak detection systems passed self-test.	
LOOP A TEST OK	The respective 10th-stage duct overheat loop circuit has passed self-test.	
LOOP B TEST OK		

EICAS Messages

Table 19-1