

## ENGINE

### GENERAL

Jet engines produce thrust by accelerating air. It is the product of the mass of the air times the increase in velocity that determines thrust output. To generate a given amount of thrust, a small volume of air can be accelerated to a very high velocity, or a relatively large amount can be accelerated to a lower velocity.

In a turbojet engine, incoming air is compressed, mixed with fuel, combusted and exhausted at a high velocity. In a turbofan engine, only a portion of incoming air is combusted. The hot air then drives the fan which accelerates a large volume of air at a lower velocity. This air is bypassed around the engine and is not mixed with fuel or combusted. The relation of the total mass of bypassed air, to the amount of air going through the combustion section, is known as the bypass ratio. The bypass ratio of the Citation Excel engine is 4.1 to 1.

The PW545A, developed by Pratt and Whitney Canada Inc., is a turbofan engine rated at 3804 pounds static thrust. A concentric shaft system supports the fan and turbine rotors. The inner shaft connects the fan ( $N_1$ ) and the axial boost stage of the low pressure compressor at the front of the engine to the three rear low pressure turbines. The outer shaft connects the centrifugal compressor ( $N_2$ ) and the forward high pressure turbine.

All intake air passes through the fan. Immediately aft of the fan the airflow is divided by a concentric duct. More than four-fifths of the total airflow is bypassed around the engine through the outer duct and is exhausted at the rear. Air entering the inner duct passes through guide vanes to the axial boost compressor stage, then through a second set of guide vanes and is compressed by the centrifugal compressor. The high pressure air then passes through a diffuser assembly and moves aft to the combustion section.

The combustion chamber is of a reverse flow design to save space and reduce engine size. A portion of the air entering the chamber is mixed with fuel and ignited. The remainder enters the chamber liner downstream for cooling.

Fuel is introduced by eleven hybrid nozzles supplied by a dual manifold. The mixture is ignited initially by two spark igniters which extend into the combustion chamber at the four and eight o'clock positions. After start, combustion becomes self-sustaining. The hot gases expand, reverse direction and pass through a set of turbine guide vanes to the high pressure turbine. The power generated by this turbine is transmitted by the outer shaft to turn the  $N_2$  compressor.

Only a small part of the energy available in the hot, high pressure air is absorbed by the high pressure turbine. As the expanding gases move rearward, they pass through another set of guide vanes and enter the three-stage, low-pressure turbine. A greater portion of the remaining energy is extracted there and transmitted by the inner shaft to the forward-mounted fan. The hot gases then exhaust into the atmosphere.

The turbofan is in effect two interrelated power plants. One section is designed to produce energy in the form of high velocity, hot air. The other utilizes some of this air to provide the power to drive the fan. The fan of the PW545A, pumping a high volume of cool low-velocity air, produces over one-half of the total thrust.



# ENGINE AIRFLOW AND CROSS SECTION

## FLANGES

- A NACELLE TO FAN CASE
- B FAN CASE TO INTERMEDIATE CASE
- C INTERMEDIATE CASE TO OUTER BYPASS DUCT
- D OUTER BYPASS DUCT TO REAR BYPASS DUCT
- E REAR BYPASS DUCT TO AIRFRAME SUPPLIED BYPASS DUCT

## STATIONS

- 0 AMBIENT
- 1 FAN CASE INLET (ID)
- 1.1 FAN CASE INLET (OD)
- 1.2 FAN BYPASS INLET
- 1.3 FAN BYPASS OUTLET
- 1.6 BYPASS EXHAUST
- 2 FAN CORE INLET
- 2.1 FAN CORE OUTLET
- 2.2 HP COMPRESSOR AXIAL INLET
- 2.5 HP COMPRESSOR INTERSTAGE
- 2.8 HP COMPRESSOR IMPELLER INLET
- 3 COMBUSTION CHAMBER INLET
- 4 HP TURBINE INLET
- 4.5 INTERTUBINE
- 5 LP TURBINE OUTLET
- 6 CORE EXHAUST

 CORE AIR FLOW  
 BYPASS AIR FLOW

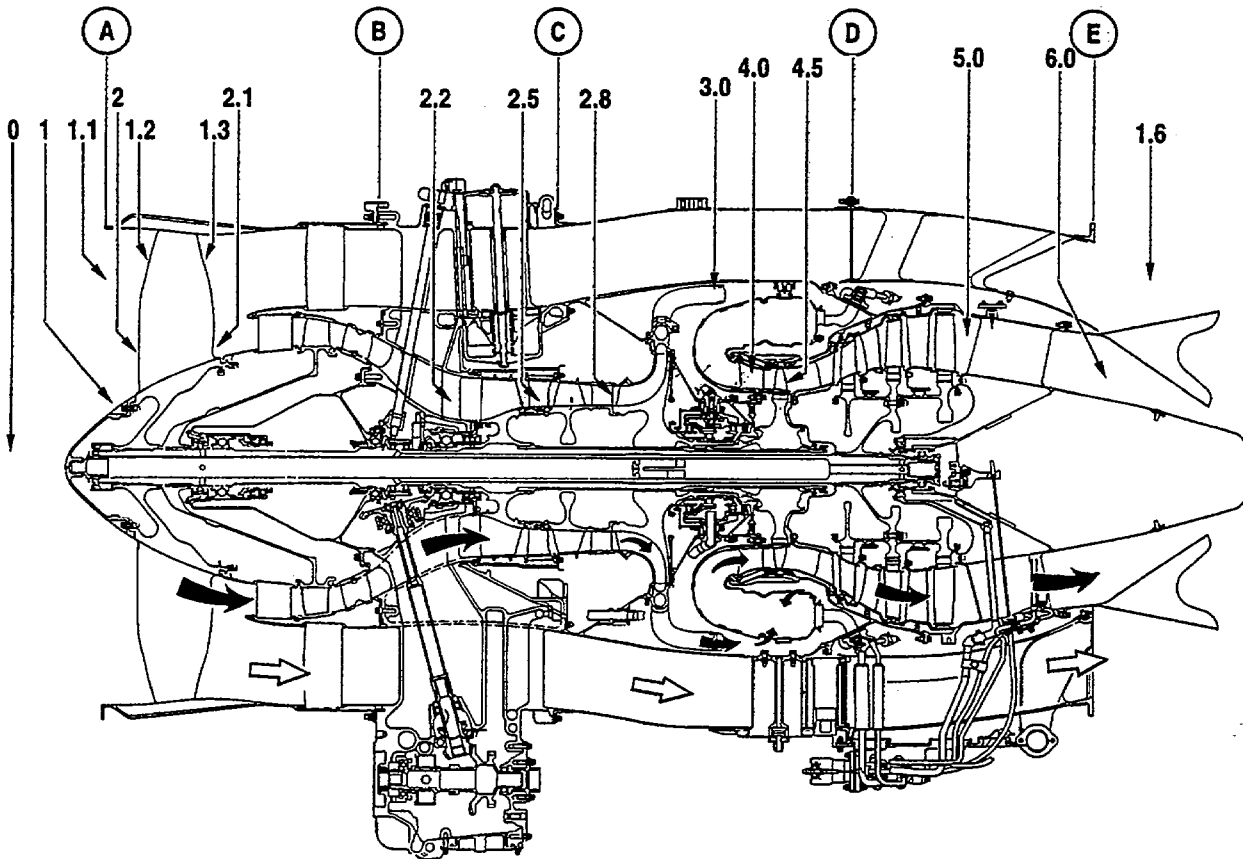

6685X1001

Figure 2-1

## ENGINE CONTROL SYSTEM

The primary function of the Electronic Engine Control (EEC) system is to control the engine low rotor speed ( $N_1$ ) and thereby the engine thrust as requested by the pilot's throttle position and the existing ambient conditions. The engine control system, which is a single channel, microprocessor based controller, provides two main modes of operation: AUTO mode and MANUAL (MAN) mode. MANUAL mode will automatically be entered in the case of an EEC major fault or may be selected by the pilot by placing the EEC switch, located on the lower left of the instrument panel, in the MAN position.

In AUTO mode the EEC provides the following functions in response to the Thrust Lever Angle (TLA) signal:

- Detented throttle, automatic thrust setting ( $N_1$  governing).
- Idle governing ( $N_2$  governing) at ground idle and flight idle.
- Acceleration and deceleration limiting.
- $N_1$  and  $N_2$  speed limiting.
- Closed loop bleed valve (BOV) control.
- Engine diagnostic system (EDS) functions.
- Overspeed protection ( $N_2$ ).
- $N_1$  or  $N_2$  synchronization.

In MANUAL mode, the Fuel Control Unit (FCU) takes over full control of the engine speed in response to the throttle position. In MANUAL mode the throttle directly controls the FCU by means of a mechanical linkage. MANUAL mode provide the following functions:

- Pilot adjustable power setting ( $N_2$  governing).
- Idle governing ( $N_2$  governing) at flight idle and anti-ice idle.
- Acceleration and deceleration limiting (ratio unit control).
- $N_2$  speed limiting.
- Closed Loop Bleed Valve (BOV) control.
- Limited engine diagnostic system functions (EDS)

The Engine Diagnostic System (EDS) provides troubleshooting tools to resolve engine and airframe related EEC system problems.

# CONTROL SYSTEM SCHEMATIC

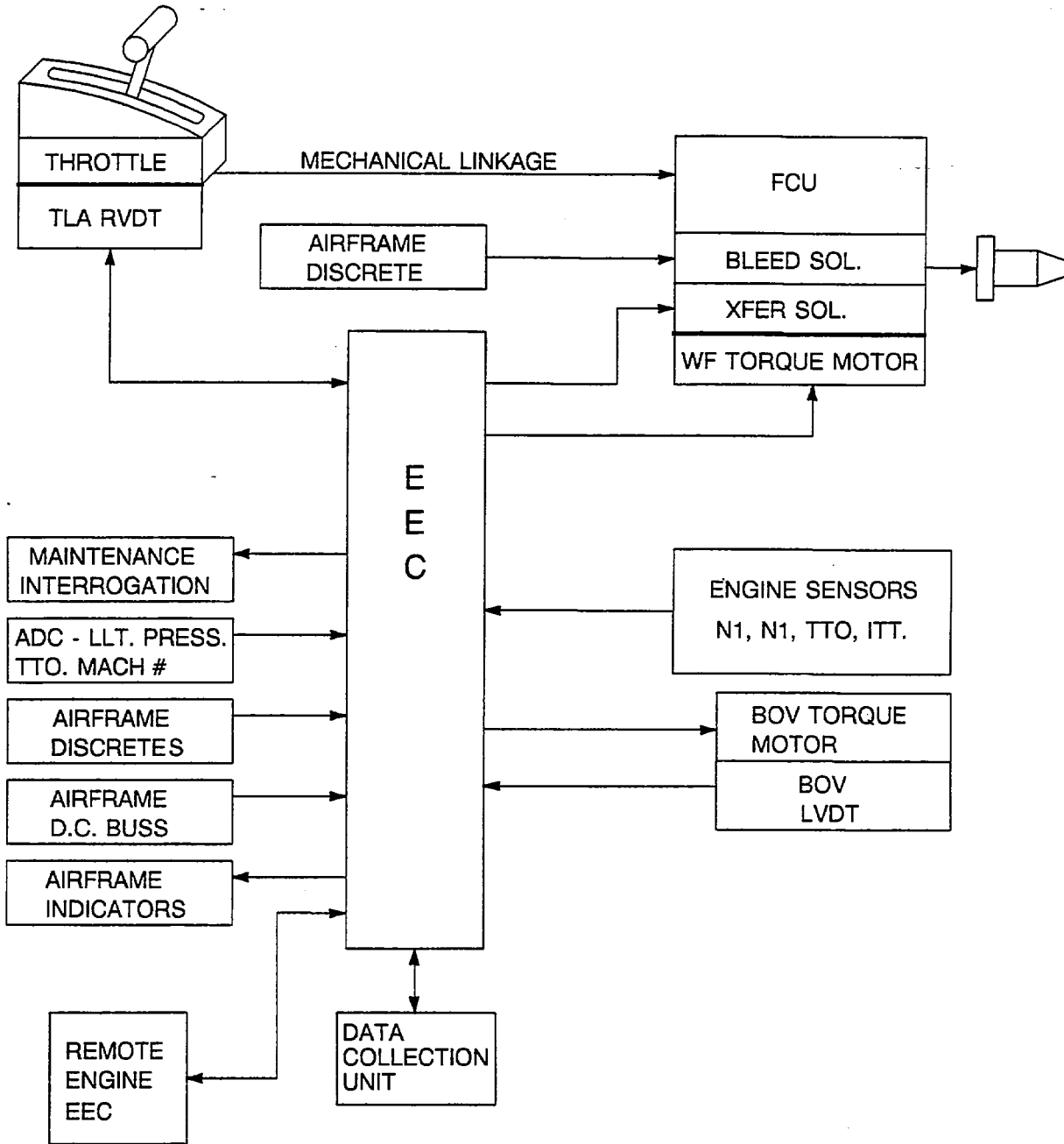

Figure 2-2

6698T1001

## GROUND IDLE

The 560 Excel is equipped with a ground idle system which automatically allows the engines to decelerate to an idle speed eight seconds after the landing gear squat switches have sensed a landing. The slower idle speed allows better taxiing control at lighter weights and in very cold temperatures, when the normal flight idle speed of 56.5% (at sea level) would require more use of the brakes, resulting in reduced brake life. The ground idle function is controlled automatically by the (EEC). A GND IDLE annunciator is located on the annunciator panel. The annunciator will illuminate when the airplane is on the ground and the engine has assumed the slower idle speed, or will assume it when the throttle is reduced to idle.

## ENGINE SYNCHRONIZER

An engine synchronizer system provides automatic  $N_1$  fan or  $N_2$  turbine RPM matching of the right (slave) engine to the left (master) engine. The synchronizer will continuously monitor the engine speeds and adjust the slave engine speed setting as required. The actuator has a range capability of 4.75 percent of fan RPM.

A rotary FAN-OFF-TURB switch on the pedestal actuates the engine synchronizer system. The FAN position synchronizes  $N_1$  RPMs. The TURB position synchronizes  $N_2$  RPMs. The OFF position deactivates the system and drives the actuator to the center of its range before stopping. An indicator light adjacent to the synchronizer switch comes on when the system is turned on. A turbine out-of-sync condition is generally more noticeable in the cockpit and a fan out-of-sync condition is usually more noticeable in the area of the rear seats. Engine synchronization is inoperative below approximately 45%  $N_1$ .

## IGNITION SYSTEM

Each engine incorporates dual exciter units and two igniters. The exciter units convert battery or generator input to high voltage Direct Current (DC), store it momentarily until a given energy level is reached, and allow it to discharge in spark form through the igniters. System wiring is such that malfunction of one igniter or exciter will not affect normal operation of the other.

Cockpit control consists of two-position R and L ignition switches. In NORM, function is automatic during start and with engine anti-ice selected. Moving the throttle to IDLE after depressing the start button activates ignition until it is terminated automatically at approximately 38 percent turbine RPM ( $N_2$ ). Continuous ignition occurs any time the respective engine anti-ice or ignition switch is ON.

A small green light adjacent to the ITT graph illuminates when both exciters are receiving electrical power. If one ignitor should fail, ignition will still be available from the remaining ignitor. If the ignition light does not illuminate when ignition is selected, or should be automatically provided, check the applicable ignition system circuit breaker on the left circuit breaker panel, or fuse in the aft power junction box.

## ACCESSORY GEARBOX

The starter/generator, fuel pump, fuel control, hydraulic pump, oil pump,  $N_2$  monopole speed sensor and an AC generator for the windshield anti-ice are driven by the accessory gearbox mounted below the engine. Power to drive the gearbox is transmitted from the  $N_2$  section through the tower shaft and a series of bevel gears. Lubrication is provided by the engine oil system.

## OIL SYSTEM

The oil system is a self-contained fuel-cooled oil cooler, which is incorporated as part of the engine. Each engine has a nominal capacity of 6.13 U.S. quarts, of which 2.14 quarts are usable.

Oil passes through a check valve, which prevents gravity flow when the engine is not running, and past a pressure relief valve enroute to the oil cooler. If system pressure becomes excessive, the relief valve reduces it by unseating and allowing oil to return to the pump inlet via a bypass line.

From the cooler, oil passes through a filter before being routed to the engine bearings and accessory gearbox. Should the filter become clogged, a bypass valve opens, allowing lubrication to continue.

Cockpit indicators receive inputs from the pressure transmitter just upstream of the oil cooler and the temperature bulb immediately downstream of the cooler.

## THRUST REVERSER SYSTEM

### DESCRIPTION AND OPERATION

The thrust reversers are of the external target type employing two vertically oriented doors or buckets, which, when deployed, direct exhaust gases forward to provide a deceleration force for ground braking. When stowed, the reversers fair into external airplane contours to form the aft portion of the nacelle. The reversers are mounted to the engine fan nozzle through an aluminum support casting and four interconnecting links per door.

### NORMAL OPERATION

The reverser system is designed for two-position operation: stowed during takeoff and flight and deployed during landing ground roll. The reversers are activated by pilot operation of the thrust reverser throttle levers and deployed by hydraulic pressure supplied by an engine-driven pump and directed to the drive actuators. The actuators are connected to a slider mechanism which is in turn connected to the reverser doors by a four-bar linkage system. The system, by design, incorporates an overcenter feature in the linkage which locks the reverser in the stowed position.

Hydraulic actuators are mounted to the support casting on each side of the reverser. The airplane hydraulic system provides pressure to these actuators which in turn operate the linkage system along a sliding track in the support casting to deploy and stow the reversers.

# ENGINE OIL SYSTEM SCHEMATIC

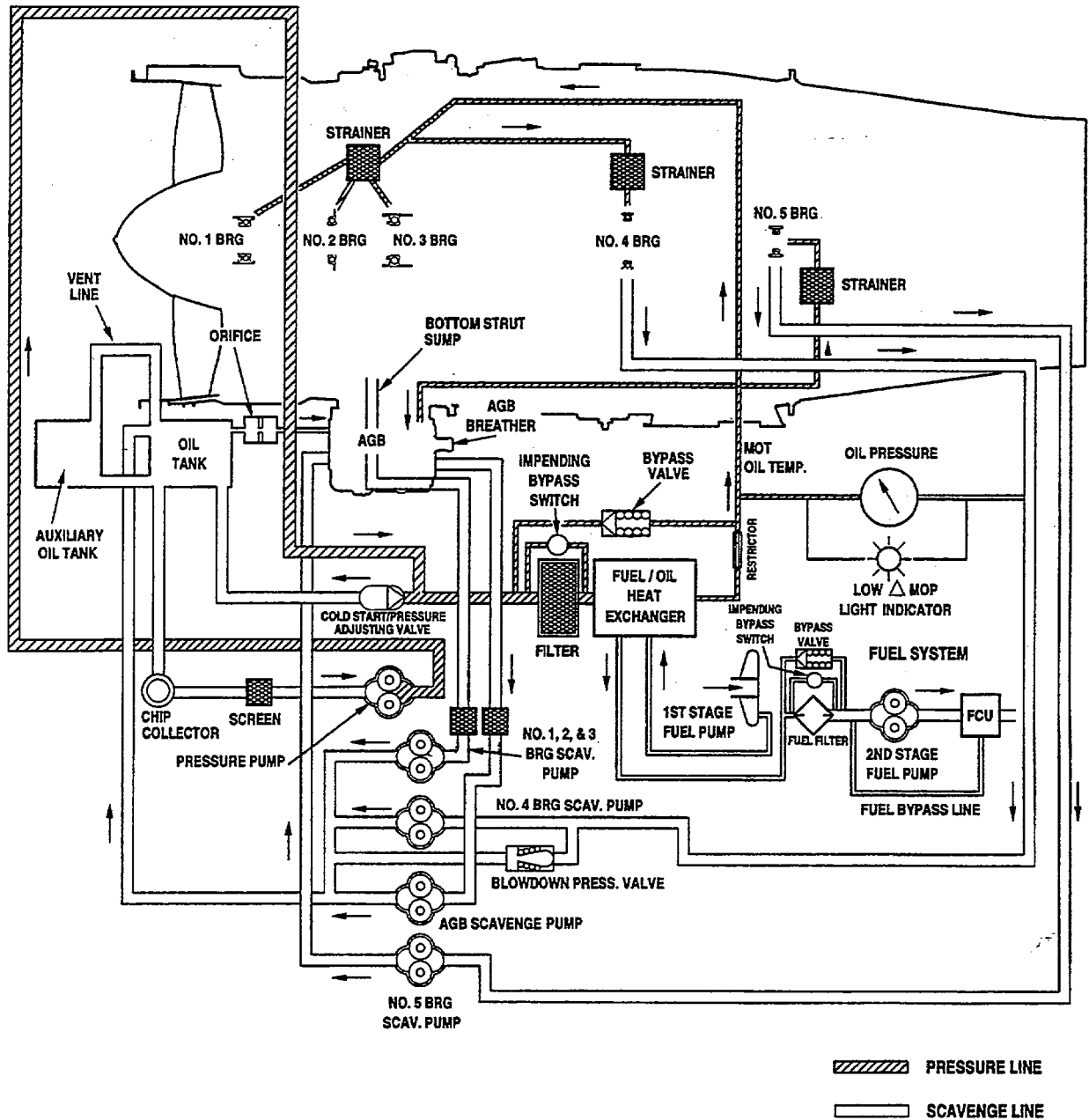

Figure 2-3

6685X1003

Control of the individual thrust reverser is through the reverse thrust lever mounted on each of the engine throttles. The reversers can only be deployed when the primary throttle levers are in the idle thrust position and the airplane is on the ground as sensed by either of the main gear squat switches. The reverse thrust lever also controls engine thrust during reverse thrust operation.

An automatic system is incorporated in the installation to reduce engine power approximately to idle if an inadvertent deployment, or stowage, of the thrust reverser should occur.

In the event of an inadvertent thrust reverser deployment, an automatic throttle retarding device will bring the throttle to approximately idle thrust depending on the amount of throttle friction that has been applied. After this device has activated, the throttle lever can be advanced resulting in corresponding reverse thrust. It is possible for a pilot, with hand on the throttle levers, to override the retraction mechanism resulting in corresponding reverse thrust should inadvertent deployment occur. Subsequent reduction of the throttle lever to idle will not result in engine flameout unless mechanical damage has resulted from the deployment.

### WARNING

- **DO NOT USE THROTTLE FRICTION OR MANUALLY RESTRAIN THE THROTTLE LEVERS DURING TAKEOFF. SHOULD AN INADVERTENT THRUST REVERSER DEPLOYMENT OCCUR, THIS COULD RESULT IN A DANGEROUS ASYMMETRICAL THRUST CONDITION.**
- **SHOULD AN INADVERTENT THRUST REVERSER DEPLOYMENT OCCUR, THE PILOT MUST ENSURE THAT THE THROTTLE LEVER IS IN THE IDLE POSITION.**

Moving the reverse thrust lever from the STOWED to the IDLE REVERSE position actuates the deploy cycle. This electrically opens the isolation valve, moves the reverser control to deploy and pressurizes the airplane hydraulic system. The isolation valve allows the airplane hydraulic system to pressurize the thrust reverser system. The amber ARM light indicates hydraulic pressure to the reverser control valve as sensed by a pressure switch.

During thrust reverser deployment, the initial movement of the actuators activates the unlocked switches. Either switch will cause the amber UNLOCK light to illuminate. Further movement of the actuator unlocks the reverser through the overcenter linkage. The remaining travel of the actuators deploys the reverser doors.

At full deployment of the reverser, the deploy switch is activated which in turn illuminates the white DEPLOY light and unlocks the pedestal-mounted throttle lock-out cam. The purpose of the lock-out cam is to prevent increasing engine thrust, once reverser deployment has been selected, until the reversers have fully deployed.

Three reverser indicator lights for each reverser are mounted on the cockpit glareshield for monitoring reverse functions: ARM, UNLOCK and DEPLOY.

### NOTE

The DEPLOY light shall illuminate in less than 1.5 seconds after the hydraulic UNLOCK light illuminates. An erroneous sequencing or a delay in the illumination of the thrust reverser lights indicates a failure in the thrust reverser system. Either or both conditions requires a maintenance check.

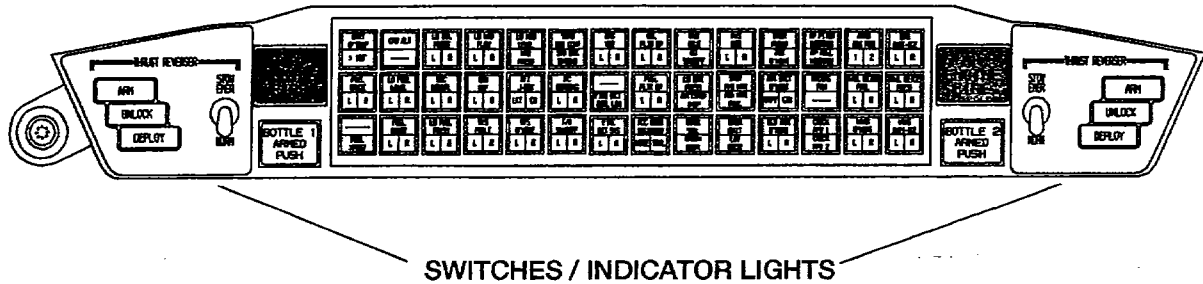

**THRUST REVERSER STOW SWITCHES / LIGHTS**

9912504-4

Figure 2-4

**WARNING**

**DO NOT ATTEMPT TO FLY THE AIRPLANE IF THE THRUST REVERSER PREFLIGHT CHECK IS UNSUCCESSFUL.**

As previously mentioned, either of the landing gear squat switches must be activated to complete the electrical circuit necessary to initiate deployment of the thrust reversers.

The thrust reverser lever(s) should not be placed in the idle reverse detent position in flight since a single failure of either squat switch could permit deployment of the thrust reverser(s). If the thrust reverser lever is placed in the idle reverse detent position while airborne, the airplane MASTER WARNING light will flash along with illumination of the ARM and HYD PRESS annunciator lights. A MASTER WARNING light, when thrust reversers are moved to deploy on the ground, means that neither landing gear squat switch has activated. To ensure actuation of the squat switches and to eliminate any delay in the deployment of the thrust reversers, it is recommended that the speed brakes be extended immediately following touchdown.

After deployment, power may be increased by moving the thrust reverser throttle levers aft for maximum reverse thrust. Thrust reverser throttle stops are set for approximately 75% N<sub>2</sub> (turbine) RPM of takeoff thrust. These stops will allow the pilot to keep his/her attention on the landing rollout instead of diverting attention to the reverse power settings.

For increased aerodynamic drag on landing roll, it is suggested that the thrust reversers remain in the deployed idle reverse power position after reverse thrust power has been terminated at 60 KIAS unless loose pavement, dirt or gravel is present on the runway. Idle reverse thrust is capable of causing ingestion of small grit at very low ground speed.

To stow the thrust reversers, move the reverse thrust lever through the idle reverse detent to the stow position. This actuates a switch in the pedestal which moves the thrust reverser control valve to the stow position. Hydraulic pressure is directed by the valve to the two actuators in the reverser which move the thrust reverser doors to the stowed position. Initial movement of the linkage toward the stowed position deactivates the deploy switch extinguishing the DEPLOY light. As each actuator moves to the fully stowed and locked position, they deactivate a thrust reverser unlocked switch. When both switches in a reverser have been deactivated, the UNLOCK light is extinguished, the airplane hydraulic system is depressurized and the affected thrust reverser isolation valve closes. This puts the ARM light out as the pressure in the line downstream of the isolation valve drops.

The thrust reversers are not to be used during touch and go landings. A full stop landing must be made once reverse thrust has been selected. Less distance is required to stop, even on a slick runway, once the reversers have been deployed, than is required to restow the reversers and takeoff.

Landings with a crosswind component of 20 knots at 30 feet above runway were demonstrated. Adequate control of the airplane was maintained during and after thrust reverser deployment. Single-engine reversing has been demonstrated during normal landings and is easily controllable.

### EMERGENCY STOW OPERATION

An emergency stow switch for each thrust reverser is located on the cockpit glare shield and will provide the same stow sequence (using the alternate 28 volt thrust reverser power source) as the thrust reverser throttle levers, in the event of a failure of the pedestal-mounted deploy and stow switch, or of the respective 28 volt direct current (VDC) bus.

Each emergency stow switch receives its electrical power through the opposite thrust reverser circuit breaker. The emergency stow function can be checked on the ground by deploying the reversers normally and then actuating each emergency stow switch. The DEPLOY and UNLOCK lights shall extinguish. The ARM and HYD PRESS lights remain illuminated. Return the thrust reverser lever to stowed position, then turn each emergency stow switch off. All lights shall be extinguished.

### FIRE PROTECTION

Engine fire detection consists of a closed-loop sensing system and detector control unit which illuminates the respective red ENGINE FIRE warning light on the cockpit glare shield if a fire or overheat condition is present. The warning light, under a transparent, spring-loaded guard, also serves as a firewall shutoff switch.

## FIRE DETECTION INDICATING LIGHTS

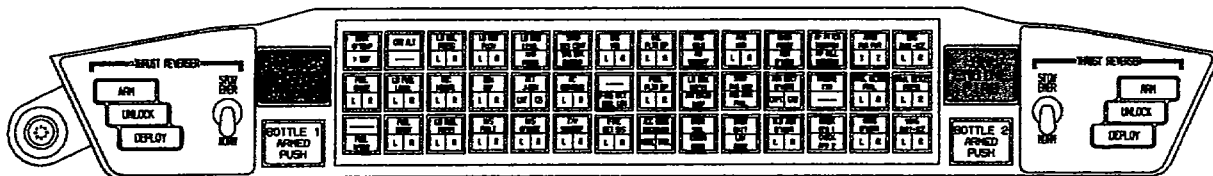

6610T1001

Figure 2-5

## ENGINE FIRE EXTINGUISHING SYSTEM

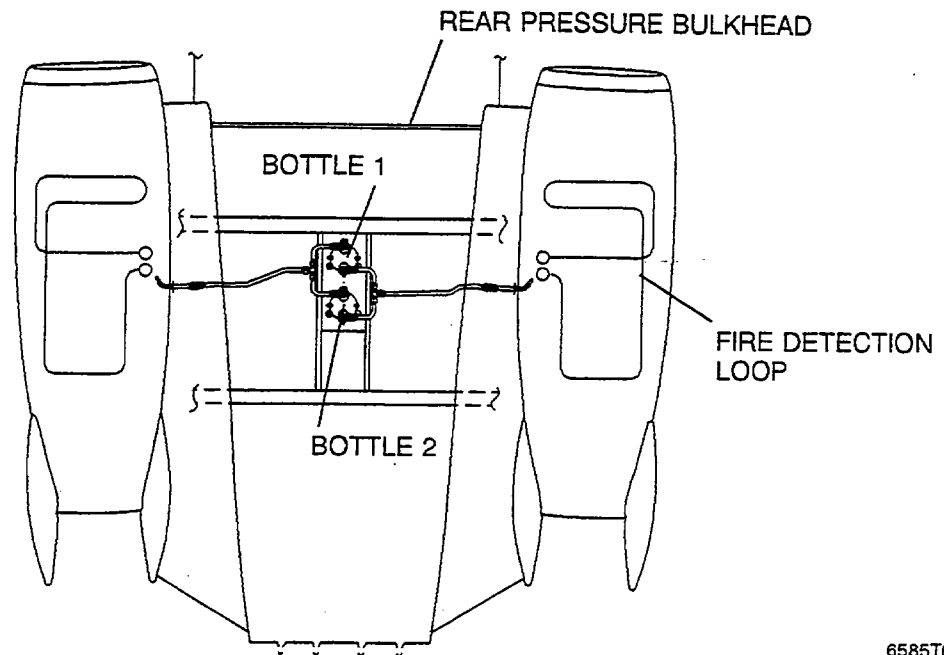

Figure 2-6

6585T6132

Lifting the guard and depressing the warning light simultaneously closes the respective firewall fuel and hydraulic valves, deenergizes the starter/generator and arms the two freon extinguishing bottles. Firewall shutoff and extinguisher arming are indicated by illumination of the respective LO FUEL PRESS, HYD PRESS, F/W SHUTOFF and GEN OFF annunciator panel lights and both white BOTTLE ARMED lights.

Once armed, either bottle may be discharged to the selected engine by pushing the BOTTLE ARMED light. The light will go out as the light is pushed. System plumbing is such that both bottles can be directed to the same engine if necessary.

Function of the lights and continuity of the sensor and detector control units is checked by placing the rotary TEST selector in the FIRE WARN position and observing illumination of both red lights and the FIRE DET SYS L R annunciator. Depressing either fire light will then illuminate both BOTTLE ARMED lights.

All test, detection and extinguishing features are electrically powered from the main Direct Current (DC) buses requiring either external power, the battery switch in BATT, or a generator on the line for operation.

## FUEL

### GENERAL

The Excel utilizes a wet wing with fuel functionally divided into two separate tanks by a fuel rib in the center of the wing (BL 0.00). Normal operation supplies fuel to the engine from its respective integral wing tank. Each half of the system holds approximately 503 U.S. gallons for a total airplane capacity of 1006 gallons of usable fuel (approximately 6790 pounds).

# FUEL SYSTEM SCHEMATIC

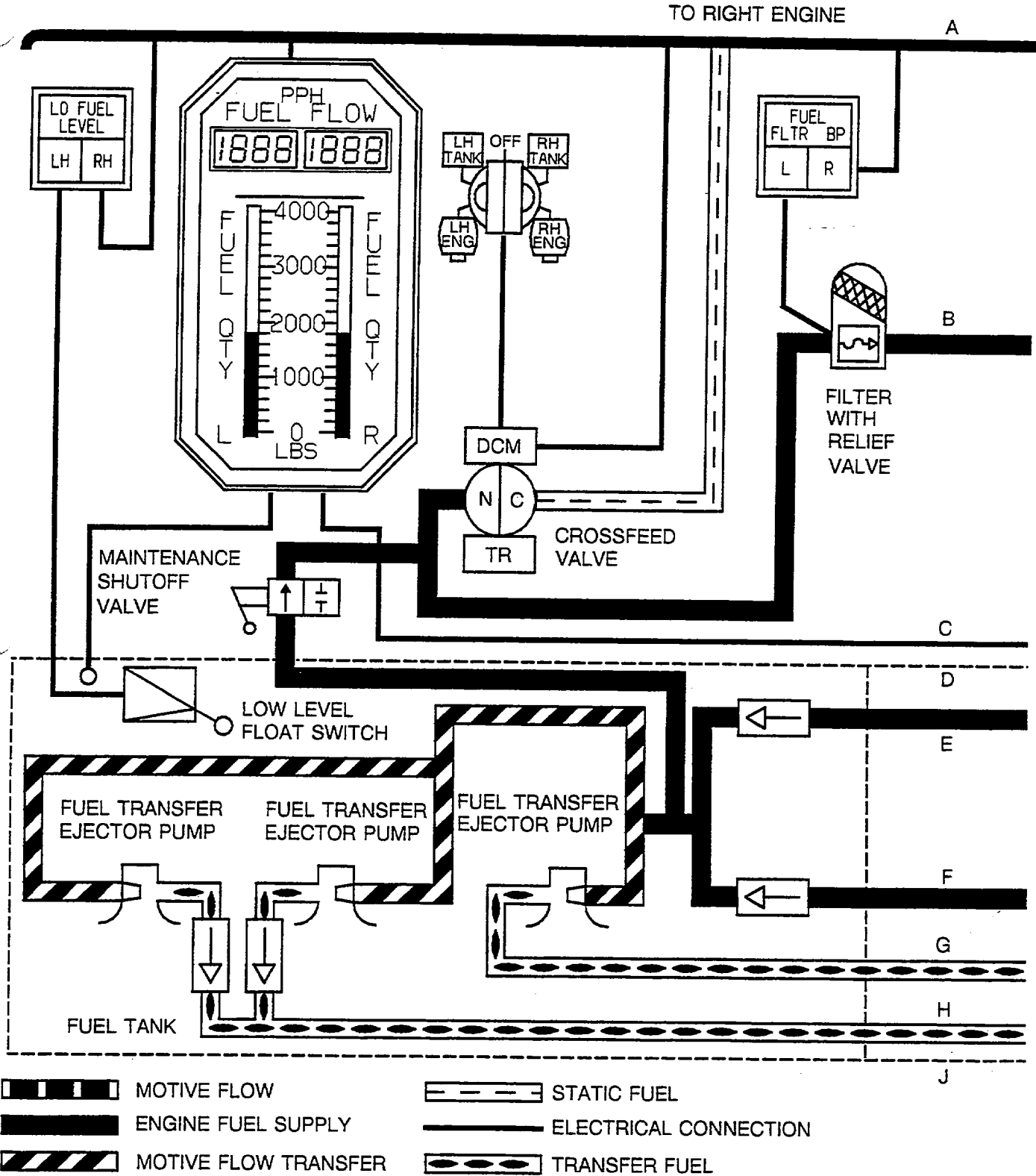

6673T2001(L)

Figure 2-7 (Sheet 1 of 2)

# FUEL SYSTEM SCHEMATIC

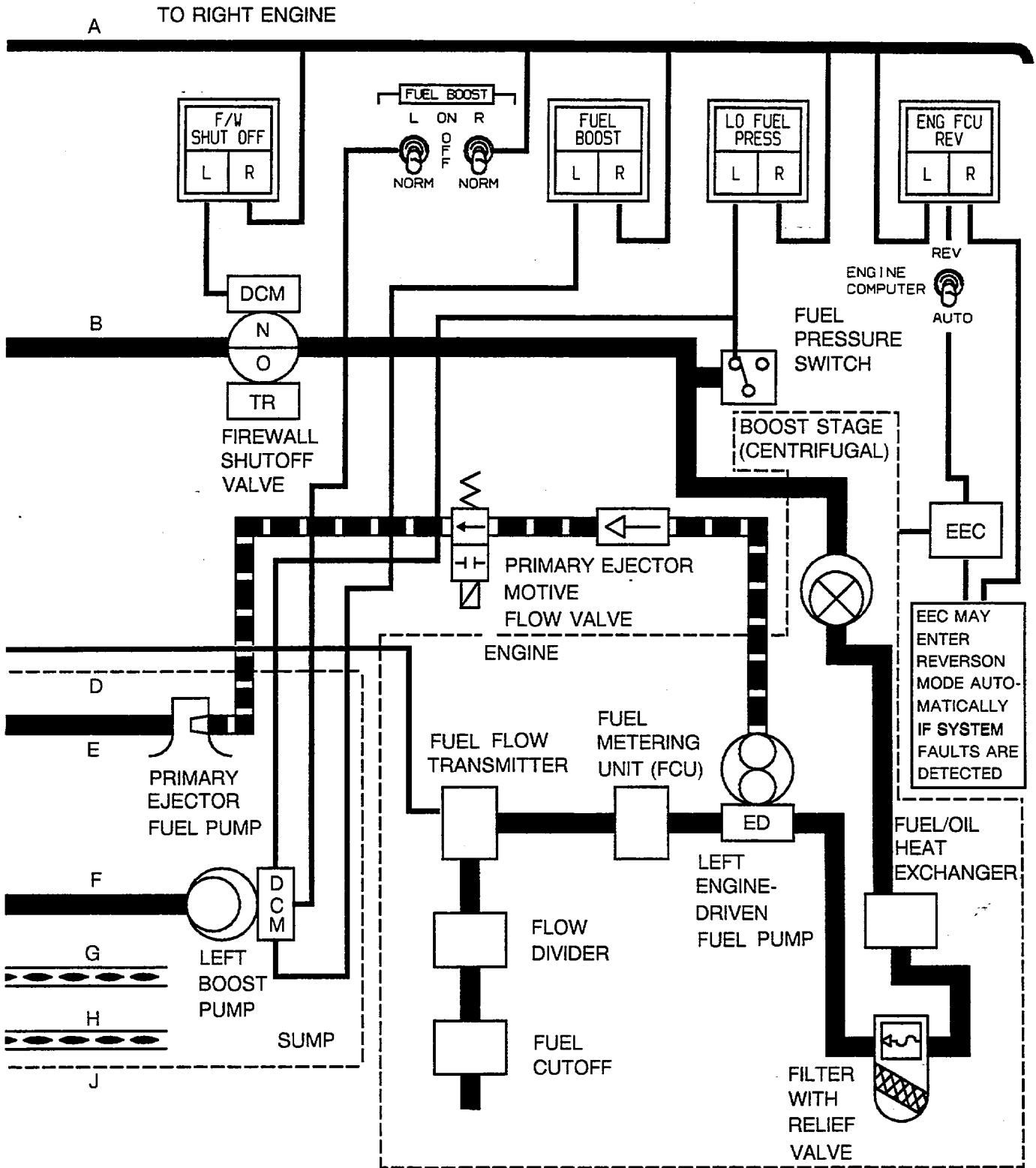

6673T2001 (R)

Figure 2-7 (Sheet 2)

Crossfeed capability is incorporated, and when selected, enables both engines to receive fuel from a single tank. A single-point pressure refueling receptacle is located on the right side of the fuselage, just forward of the wing. It permits simultaneous servicing of both sides of the fuel system. Refer to the Maintenance Manual, Chapter 12 for fuel servicing procedures.

System operation is fully automatic throughout the normal flight profile. Fuel system control and monitoring is available through the boost pump switches, crossfeed switch, fuel quantity and flow indicators, and annunciator panel lights which warn of abnormal system operation. A low fuel level warning system functions independently of the normal fuel quantity indicating system.

## WING FUEL TANKS

Fuel for each tank is contained between the fore and aft spars, and from the center point of the wing (BL 0.00) outboard to the wing tip (WS 284.52) with necessary deviations in the wheel well area. Fuel flows freely inward across the ribs through lightening holes and stringer cutouts, but is restricted from flowing outward by flapper valves located in three different wing ribs.

The engine feed hopper is located forward of the rear spar and extends outward approximately 11.5 inches from each side of centerline. It is sealed except for vent openings at the top (in order to maintain a full hopper under low fuel conditions). It is equipped with flapper valves that allow for gravity fuel flow into the hopper. Components which supply fuel to the engine are located within the hopper.

A vent system ensures ambient pressure within the tank and fuel expansion overflow capability. A float-type valve restricts flow through the vent during inflight maneuvering. Design features of the vent prevent it from becoming blocked by inflight ice accumulation.

## DRAIN VALVES

Five fuel tank drains (push to drain, turn to lock) are located underneath each wing. Four of the drains are located near the wing center line (from fore to aft) and one drain is located outboard of the wheel well.

## VENT SYSTEM

The left and right tanks have separate yet similar vent systems, with each tank containing pressure/vacuum relief provisions separate from the vent system. Components of the vent system are as follows:

### CLIMB VENT LINE

This is a series of tubes which extend from the outboard surge tank to the forward upper corner of the wing tank, just inboard of WS 34.00. The climb vent line serves as the primary vent during climb and descent at normal fuel levels and attitudes.

### VENT SURGE TANKS

The vent surge tanks are located near each wing tip in a semi-isolated location, and normally do not contain fuel. These surge tanks function as a fuel collector for relatively small amounts of fuel which may be trapped in the climb vent line during flight maneuvers and climb attitudes, or during thermal expansion of the fuel. Each surge tank is vented to atmosphere by a flush, non-icing NACA scoop located on the lower wing surface. The vent scoop is connected to the surge tank with an open-ended tube located at a high point in the surge tank, preventing fuel from siphoning overboard. This also prevents fuel from spilling overboard during wing-low conditions of flight, or in uncoordinated turns.

Additionally, each surge tank also contains a vent valve which allows air to either enter or leave the fuel cell through the surge tank. It is the primary vent used during level attitudes, including refueling and defueling. The valve is float actuated so that whenever fuel moves to the wing tip for any reason, the valve closes, preventing fuel flow into the surge tank. Each surge tank also contains an inboard mounted flapper valve which allows fuel to drain back to the wing tank and prohibit it from flowing into the surge tank.

### RELIEF VALVES

Each wing tank incorporates a relief valve which prevents excessive positive or negative tank pressures during single point refueling, or during other conditions if the the normal vent system is blocked. The valve automatically reseats itself once system pressure has returned to normal pressure levels.

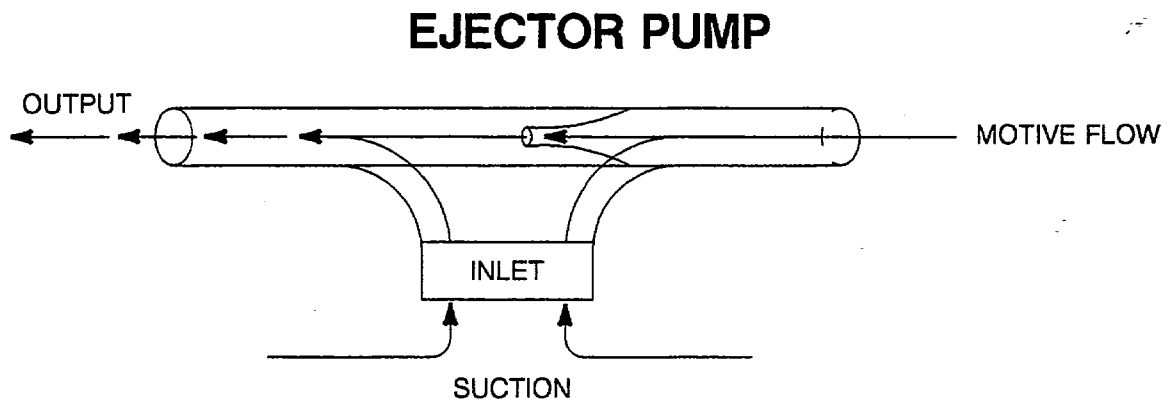

Figure 2-8

6585C6118

## ENGINE FUEL SUPPLY COMPONENTS

Each engine is supplied with fuel primarily by the motive flow-powered ejector pump and secondarily by the electric boost pump. Both components for each engine are located in the engine feed hopper.

The primary ejector pump is powered by high pressure motive flow from the engine fuel control unit, and it supplies low pressure fuel to its respective engine during normal fuel operation and operates only when that engine is operating. It also supplies the scavenge ejectors with low pressure motive flow. A check valve is installed in the pump discharge fitting to prevent backflow through the pump. The 28 VDC wet electric motor pump is used for engine starting, fuel crossfeed, APU only operation (when so equipped), and in the event of primary ejector pump failure. The pump includes a cartridge element for the motor and impeller which allows motor replacement without the need for airplane defueling.

A pressure switch is located in the engine nacelle area and actuates between 5.3 and 5.8 PSIG with decreasing pressure, and deactivates by 7.5 PSIG with increasing pressure. Actuation of the switch is indicated by the LO FUEL PRESS L or R light on the annunciator panel, and will cause the boost pump to operate.

Each fuel supply line (left engine and right engine) also contains a firewall shutoff valve. These valves are located behind the rear spar in an access panel area, and are actuated by the fire tray annunciator/switches.

## FUEL SCAVENGE COMPONENTS

Fuel for the engine feed hopper is supplied by the fuel scavenge system (and to a much lesser extent by gravity flow). This system uses ejector pumps to pick up fuel at three distinct points in the inner portion of each wing tank and deliver it to the hopper area. The scavenge ejectors are powered by low pressure motive flow from the primary ejector pump. The scavenge system also contains wire mesh screens which minimize contamination reaching the hopper and fuel system components.

## CROSSFEED COMPONENTS

The crossfeed system allows either or both engines and the auxiliary power unit (if equipped) to be fed from the primary ejector and/or auxiliary boost pumps in either tank. The system consists of the following components:

### CROSSFEED VALVE

This is a normally closed, motor-operated ball valve. This valve is installed in the rear spar area of the engine feed hopper, and connects left and right engine supply manifolds. The motor portion of this valve is installed outside of the engine feed hopper to allow motor removal/installation without removing the ball valve.

### MOTIVE FLOW SHUTOFF VALVE

These normally-open valves are installed aft of the rear spar area. Each motive flow shutoff valve is installed in-line to allow normal left engine/left tank and right engine/right tank feeding operation. In crossfeed operation, one of the valves will be closed (dependent on switch position).



## CROSSFEED OPERATION

Crossfeed operation is controlled by a selector on the left switch panel labeled L TANK - OFF - R TANK and allows both engines to be supplied from one fuel cell.

Selecting either tank automatically turns on the electric boost pump in that cell, opens the crossfeed valve, illuminates the XFEED annunciator on the annunciator panel, and three seconds later closes the motive flow shutoff valve on the engine receiving crossfeed. Returning the selector to OFF reverses the sequence.

### NOTE

When selecting crossfeed, it is important to allow sufficient time for the cycle of events to be completed before returning the switch to OFF. Not allowing sufficient time can interfere with the normal operation of the time delay relays resulting in loss of control of the crossfeed system. If experienced, this condition can be corrected by placing the battery switch in EMER and turning both generators off. After several seconds, electrical power can be restored and crossfeed will function normally.

## SINGLE POINT REFUEL/DEFUEL SYSTEM

The single-point refueling system is provided to enable the airplane to be refueled or defueled more safely and conveniently by connecting to one port, which is not open to the atmosphere. Advantages of a single-point refueling and defueling include minimized refuel/defuel time, reduced possibilities of fuel contamination, reduced static electricity hazard, less airplane skin damage, and there is no personnel contact with the fuel.

The refueling/defueling system is independent of the airplane system. It is designed for refueling with a truck or refueling hydrant (pit) having single point provisions. The system allows for fuel to be delivered to both wings, or to each wing independently. Major components of the system include the refueling/defueling adapter (receptacle), the precheck control panel, refuel/defuel shutoff valve, the pilot (precheck) valve, the low level pilot valve, the high level pilot valve and associated system plumbing.

Single-point refueling is accomplished by connecting the refueling truck or refueling pit equipment to the airplane at the single-point refuel/defuel adapter on the right side of the fuselage just forward of the wing leading edge.

Prior to beginning refueling, a precheck of system operation is accomplished at the precheck panel located adjacent to the adapter. A successful precheck indicates that the system is working properly and that system shutoff will occur when the tanks are filled. If the precheck is not successful, the system must not be used until repaired. System damage or dangerous spills can occur.

Precheck is accomplished by lifting the precheck handle and applying fuel pressure. Flow should stop within approximately thirty seconds. During the precheck operation fuel is pumped into a small bowl at the high level pilot valve, which will operate the refuel shutoff valve, stopping the flow of fuel just as it does when the tank is full.

When one wing tank reaches the full level and flow is discontinued, the opposite wing (if not yet full) will receive the full refueling flow until it also reaches the full level. When both wings have been filled, the system will stop the flow of fuel just downstream of the refuel adaptor. A check valve in the adaptor will ensure no fuel is spilled when the hose is removed from the panel. When refueling the wings to less than full, small differences in fuel flow within the single point distribution system may result in slightly more fuel entering one wing tank than the other.

### **DEFUELING OPERATION**

Single-point defueling is accomplished using the same adapter as the single-point refueling system. When defueling is desired, the manual defuel select valves must be opened for each tank not requiring defueling. When any of the manual defuel select shutoff valves are opened, the corresponding defuel valve is deactivated.

When negative pressure is applied through the defueling equipment, the defuel shutoff valves are opened and fuel is drawn from the tank through the open defuel shutoff valve. When the tank is depleted of its fuel, the defuel shutoff valve is pressurized by tank pressure. The resulting force imbalance closes the defuel valve and terminates the defueling operation.

### **ENGINE FUEL SYSTEM**

The two-stage, engine-driven pump, mounted on the accessory gearbox, supplies high pressure flow to the fuel control unit. Fuel enters the pump at low pressure from the primary ejector pump and exits at high pressure. Part of the pump output is bypassed through the motive flow valve to drive the primary ejector pump and the remainder is directed downstream to the fuel control. This positive pressure to the fuel control must be maintained by the engine-driven pump for the engine to continue to operate.

The fuel control unit is mounted on the engine-driven fuel pump and determines the proper fuel schedule for all phases of engine operation.

A flow divider downstream of the fuel control unit provides proper fuel distribution to the combustion chamber by dividing the flow from the fuel control between the primary and secondary fuel manifolds. It also acts as a fuel shutoff valve, bypassing fuel back to the pump. When the throttle is closed, fuel flow is terminated at the flow divider and the fuel manifold is drained. A fuel canister assembly collects the fuel at engine shutdown and returns it to the main tanks during the next flight.

### **FLOW INDICATORS**

Fuel flow rate is measured downstream of the fuel control and presented on a digital format gauge in pounds per hour per engine.

**FILTER**

Each engine-driven pump incorporates a filter. A pressure differential sensing switch and a bypass valve alert the pilot and allow flow to continue should the filter become obstructed. The switch closes and illuminates the FUEL FLTR BP annunciator panel light if the difference between filter inlet and outlet pressure reaches 6 to 8 PSI. The bypass valve will open at 9 to 12 PSI differential. Illumination of the annunciator panel light indicates impending or actual bypass of fuel around the filter.

**QUANTITY INDICATORS**

Seven capacitance-type probes and one temperature compensator in each cell supply information to the vertical scale quantity gauge. The indicator converts these signals into fuel weight and displays it in pounds per cell.

**LOW LEVEL WARNING**

Low level warning functions independently of the normal quantity indicating system and provides a visual warning to the crew when a minimum amount of usable fuel remains in either tank. The system consists of a float switch in each fuel cell and L and R LO FUEL LEVEL annunciator panel lights. A minimum usable fuel quantity of 360 pounds in either tank will illuminate the associated light. When operating with light fuel loads, it is possible for the lights to illuminate momentarily in turbulent flight conditions or while taxiing on rough surfaces. The system is calibrated to give an accurate indication in level unaccelerated flight.

**FUEL SHUTOFF**

Electrically operated firewall shutoff valves can be individually closed by depressing the LH or RH ENGINE FIRE button. Actuation of a shutoff valve will be indicated by illumination of the respective LH or RH F/W SHUTOFF annunciator panel light.

Protection against severe overspeed or explosive structural failure of the engine is provided by an automatic fuel shutoff. It is actuated through mechanical linkage should a predetermined amount of rearward displacement take place on the turbine shaft. Fuel flow to the manifold is terminated, automatically shutting down the engine.

