

## GENERAL

Environmental and temperature control on the Citation XLS is provided by pre-cooled engine and/or APU bleed air. The conditioned bleed air is distributed in a series of ducts and vents. The primary means of altering temperatures in this system involves changing the amount of warm bleed air allowed to mix with cold air.

The environmental control system consists of the Environmental Control Unit (ECU), the Air Distribution System, and the Temperature Control System. The various systems and their components are listed as follows:

## ENVIRONMENTAL CONTROL UNIT

The tailcone mounted ECU is designed to take pre-cooled engine and/or APU bleed air from both engines and produce cold air for use in the temperature and distribution system. This conditioned air also serves as the source of pressurization for the entire pressure vessel. The ECU consists of a primary heat exchanger, a secondary heat exchanger, an Air Cycle Machine (ACM), a water separator and an over-temperature switch.

Initially, hot engine bleed air is extracted from both engines and run through a pylon mounted air-to-air heat exchanger. This exchanger lowers the temperature of the air to approximately 475°F. This pre-cooled air from each pylon is then routed together and plumbed into the primary heat exchanger, where temperature drops from 200°F to 300°F. Air is then routed into (and out of) the ACM, through the secondary heat exchanger and back into the ACM where air eventually exits at a temperature which may be well below freezing. An in-line temperature sensor constantly measures this air temperature, and automatically mixes hot bleed air to provide a constant 35°F to 40°F temperature output. This controlled temperature cold air is then run through a water separator to remove entrapped moisture.

After exiting the water separator, the cold air is ducted overhead to provide cool air distribution, or mixed with bleed air and ducted toward floor and armrests to provide warm air distribution.

### NOTE

Overtemperature protection for the ACM is provided by a temperature sensor mounted in the compressor discharge section of the ACM. When the switch senses an overheat condition in flight (temperature above 420°F), it closes the mass flow regulating shut-off valves in the tailcone, opens the emergency pressurization valve and annunciates both the EMERG PRESS ON and ACM O'HEAT lights.

## AIR DISTRIBUTION SYSTEM

When conditioned air leaves the water separator at between 35°F to 40°F, it is ducted forward to a four-outlet wye near the rear pressure bulkhead. Two of the wye ducts are plumbed into the overhead distribution system, terminating at the cockpit overhead wemacs. This overhead system contains only cold air. The remaining two wye ducts are plumbed into the cabin/cockpit warm air distribution system, and temperature in this ductwork is controlled by mixing cold air with hot bleed air. The distribution sub-systems are described in greater detail below.

## Cessna Citation XLS - Environmental & Temperature Control

the tailcone mounted EOC. On the air side of the air pressure bulkhead, this single line splits into the four-outlet wye. After penetrating the pressure vessel, the cold air lines (left and right) feed into left and right overhead ducts which run the length of the cabin and terminate in the cockpit. An outlet (wemac) is provided at each passenger and flight crew location. These outlets are operated individually, and may be rotated from a full open to a full closed position. This overhead distribution duct is continuously pressurized with cold air when the engines and/or APU are running and bleed air is being supplied.

## COCKPIT RECIRC BOOST FAN CONTROL

A30555

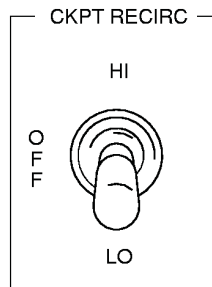

6618T1359

Figure 2-21

**CABIN AIR DISTRIBUTION** - The lower cabin air distribution system supplies conditioned air through the left hand lower supply duct. When air enters the cabin, it is split into several paths; the left hand armrest and foot warmer ducts, the dropped aisle ducts located on the left hand side of the dropped aisle, and to the right hand armrest and foot warmer ducts. The foot warmer and armrest ducts are of a piccolo tube design that allows the air to flow evenly over the length of the cabin.

**COCKPIT AIR DISTRIBUTION** - The cockpit air distribution system supplies conditioned air through the right hand lower supply duct. The air enters in the aft cabin and is ducted underneath the right hand seats towards the cockpit. After reaching the cockpit, the air is split off into side wall diffusers, side window defog and forward bulkhead diffusers.

**COCKPIT VENT SYSTEM** - The cockpit vent system consists of side console air outlets, foot warmers and console wemacs which are supplied by a fan located in the foot warmer ducting. The side console air outlets are installed on the top surface of the pilot's and copilot's side consoles. The right console air outlet is connected to the cockpit air duct inside the console. The left console air outlet is supplied air through a crossover duct which extends from the co-pilot's side console to the pilot's side console and follows the lower fuselage contour. The side console air outlets are opened and closed by rotating the nozzles. The left and right foot warmer outlets are mounted in the forward crossover ducting. The side console wemacs are supplied with air pulled in from the foot warmer ducts. Air is supplied through flex ducts connected to a center outlet, between the left and right foot warmers on the forward ducting. The cockpit recirc fan is mounted in the center of the forward foot warmer duct. The cockpit recirc fan is controlled electrically by a fan switch on the co-pilot's instrument panel. Condensation on the cockpit side windows is prevented by using frost panels to prevent moist cockpit air from coming in contact with the cold outer window surface.

## Cessna Citation XLS - Environmental & Temperature Control

There is a small vent hole placed in the upper corner of the frost pane to allow the air to flow over the pane and into the cockpit.

### WINDSHIELD DEFOG

Windshield defog is accomplished by electric windshields powered by engine driven AC alternators. The windshield heat should be turned on prior to descent from altitude to provide adequate clearing for descent into high humidity conditions. If the outside windshield fogs over after landing, the electric windshield anti-ice system may be turned to the O'RIDE position.

### TEMPERATURE CONTROL SYSTEM

The basic principle of operation in the temperature control system is to mix a stream of cold air from the ECU (35°F to 40°F) with a stream of warm bleed air (approximately 475°F) from either engine and/or APU. This mixed air passes through the aft pressure bulkhead and is then distributed throughout the cockpit and cabin area via a series of under floor ducts and distribution points.

Once inside the cabin, this air may further mix with overhead cold air to create a composite temperature conducive to passenger comfort. Two sensors measure this composite temperature and convey data to the cockpit mounted display and controller. Individual zone controls allow the flight crew to set different temperatures in the cockpit and in the cabin area (typically between 65°F to 85°F).

The temperature control system consists of three temperature control valves (cabin, cockpit and ECU low limit), two mixing muffers, three duct temperature sensors, two zone temperature sensors, two duct overheat temperature switches, and the temperature controller (which is integral with the selector/indicator).

**TEMPERATURE CONTROL VALVES** - Three temperature control valves are utilized to regulate the amount of hot bleed air mixed in with the cold air out of the ECU. Two of the valves are located just aft of the aft pressure bulkhead, and the third is located near the ECU. The ECU valve receives commands from the cockpit temperature controller, but its operation is automatic. The other two valves also receive commands from the cockpit temperature controller in response to either manual or automatic temperature change requests from the flight crew.

**MIXING MUFFERS** - The mixing muffers are devices that mix the hot and cold air streams. The mixing muffer surrounds the conditioned air duct and injects hot bleed air into the conditioned air duct. The quantity of bleed air to be mixed is controlled upstream by the temperature control valves. The mixed air becomes temperature controlled conditioned air and is routed to the cabin and cockpit.

**DUCT TEMPERATURE SENSORS** - The duct temperature sensors monitor the air temperature at three points in the system. Sensors are located near the aft pressure bulkhead (left and right lower duct locations) and downstream of the water separator in the tailcone area.

**ZONE SENSORS** - Two zone sensors sample representative air temperature and display temperature data on the controller. Each sensor contains a small fan which pulls cabin air across the sensor to provide a more representative zone temperature. The cockpit zone sensor is located in the right hand side console. The cabin zone sensor is located in the aft cabin in the passenger service unit.

## Cessna Citation XLS - Environmental & Temperature Control

(left and right lower duct) to provide an over-temperature indication. If either switch detects an over-temperature condition (temperature exceeds 300°F), the switch will close, causing the DUCT O'HEAT CKPT or the DUCT O'HEAT CAB annunciator to illuminate in conjunction with the MASTER CAUTION warning.

**TEMPERATURE CONTROLLER** - The temperature controller is mounted on the center tilt panel and provides dual zone adjustments and monitoring of both the cockpit and cabin systems. The TEMP SEL knobs provide for automatic and manual settings of the temperature (both zones), and a center knob allows the cockpit or cabin selected temperature and the cockpit or cabin duct temperature to be monitored. A digital display in the center of the controller shows temperature readout (in Fahrenheit) of the selected sensor.

## TEMPERATURE CONTROLLER

A35136

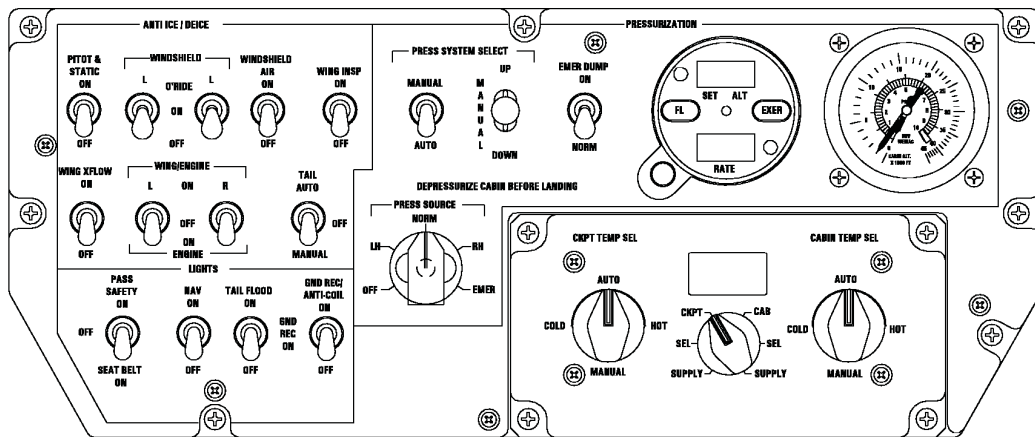

6618T1150

Figure 2-22

**TEMPERATURE CONTROLLER ERROR CODES** - The temperature controller is equipped with bit test (B.I.T.E.) capabilities. This test is initiated each time power is applied to the temperature controller.

When the B.I.T.E. is enabled, a display check and a test of the associated system are conducted immediately and on each subsequent temperature controller power-up. If system faults are discovered, one or more of the following error codes may be displayed on the temperature display. Error codes displayed are for the specific compartment selected.

## Cessna Citation XLS - Environmental & Temperature Control

<u>Test Code</u>	<u>Meaning</u>
888	Test of display elements is being conducted.
E0	B.I.T.E. enable and test of the associated system is being conducted.
E1	Zone temperature sensor resistance is too low.
E2	Zone temperature sensor resistance is too high.
E3	Duct temperature sensor resistance is too low.
E4	Duct temperature sensor resistance is too high.
E5	Temperature control valve closing current is too low.
E6	Temperature control valve opening current is too low.
E7	Temperature control valve closing current is too high.
E8	Temperature control valve opening current is too high.
E9	Idle current is too high.

2. An unusually hot or cold sensor may cause E1 through E4 to be displayed. These error codes will clear themselves when the sensors enter the normal operating range. The normal operation of the B.I.T.E. is with the CKPT TEMP SEL or CABIN TEMP SEL switch set to AUTO. Error codes E5 through E9 are latched and will continue to be displayed while the B.I.T.E. is enabled until a new B.I.T.E. sequence is initiated. A B.I.T.E. sequence is initiated by disabling, then enabling the B.I.T.E. by turning the system power off and back on.

**ENVIRONMENTAL CONTROL SYSTEM**

A19952

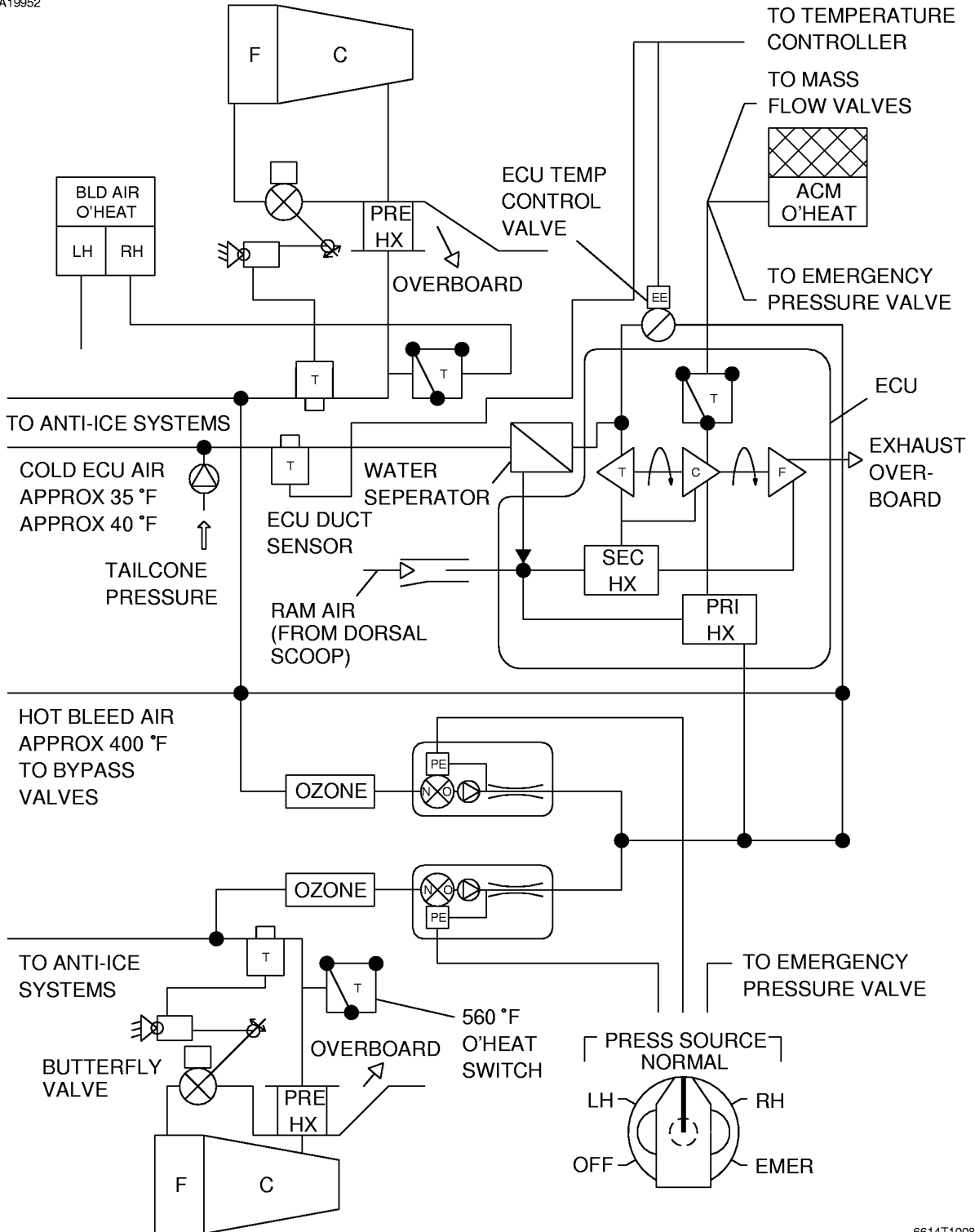
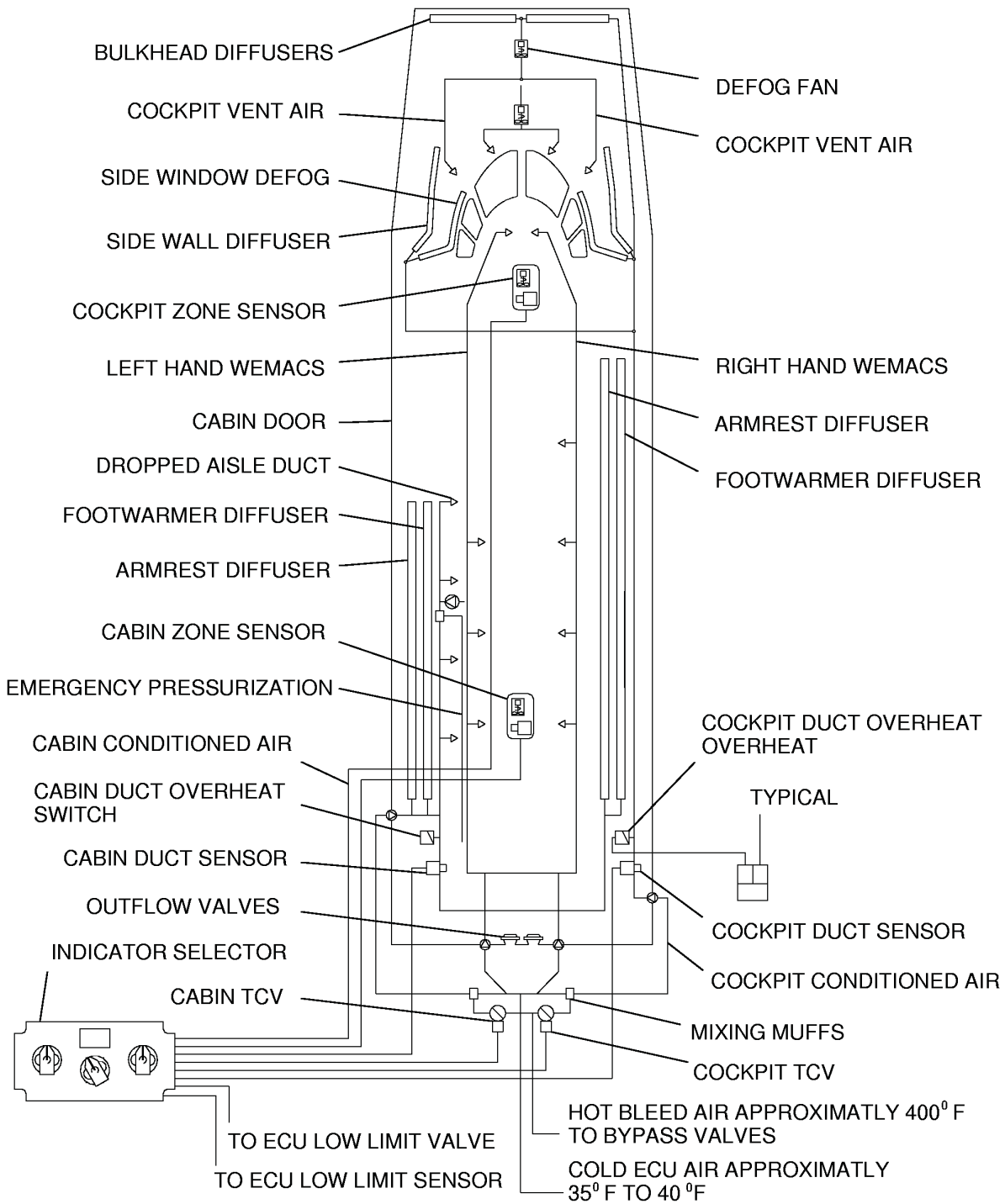

Figure 2-23 (Sheet 1 of 2)

6614T1008

**ENVIRONMENTAL CONTROL SYSTEM**

A35716



6685T1004

Figure 2-23 (Sheet 2)