

12.11 (ATA 30) ICE AND RAIN PROTECTION

12.11.1 Introduction

The Dash 8-Q400 aeroplane is approved for flight into known icing conditions. Ice and rain protection includes de-icing, anti-icing, and rain removal systems. An ice detection system supplies early indication of aeroplane icing conditions.

12.11.2 General

The ice detection system uses probes to actively detect icing conditions and displays ice detection information on the flight deck.

The de-icing system uses engine bleed air to operate conventional inflatable boot sections installed on the leading edge surfaces of the wings, horizontal and vertical stabilizers, and nacelle inlet lips (Figure 12.11-1).

The anti-icing systems use electrical heating elements to prevent ice formation. The system heats:

- leading edges of the propeller blades (de-icing)
- pilot's, copilot's and standby pitot/static probes
- left and right AOA vanes
- left and right engine intake flanges
- both windshields and pilot's side window

Conventional electrically operated windshield wipers supply rain removal for the windshields.

LEGEND

1. Outboard Horizontal Stabilizer Boots.
2. Inboard Horizontal Stabilizer Boots.
3. Upper Vertical Stabilizer Boot.
4. Lower Vertical Stabilizer Boot.
5. Extension and Outboard Wing Boots.
6. Outboard and Inboard Centre Wing Boots.
7. Inboard Wing Boots.
8. Propeller Blade Heaters (All Blades).
9. Nacelle Inlet Lip Boot (Both Sides).
10. Centre Boots.
11. Angle of Attack Vane (Both Sides).
12. Pilot's Side Window.
13. Pilot's Windshield.
14. Ice Detector Probe (Both Sides).
15. Pitot/Static Probes.
16. Copilot's Windshield.

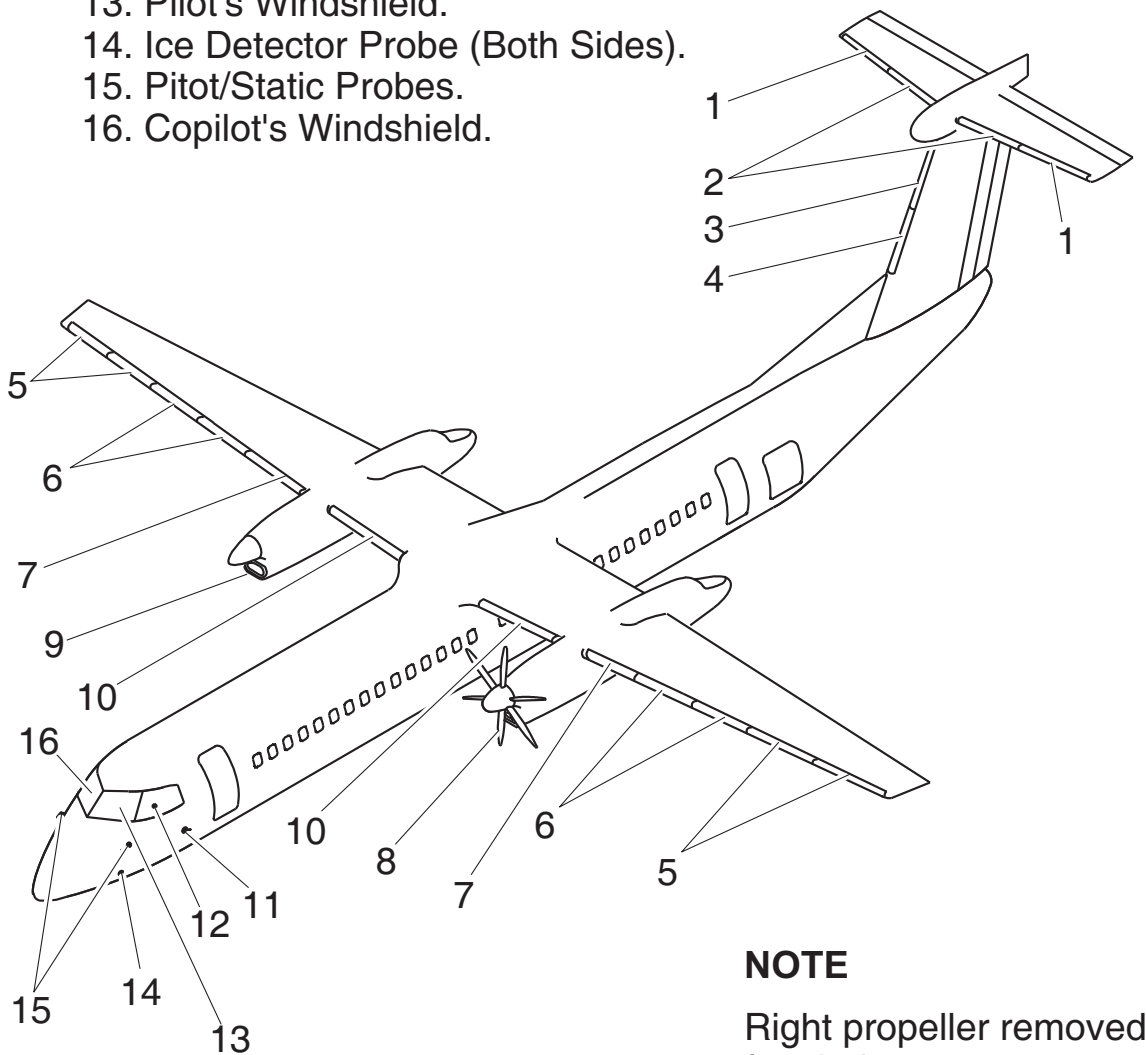
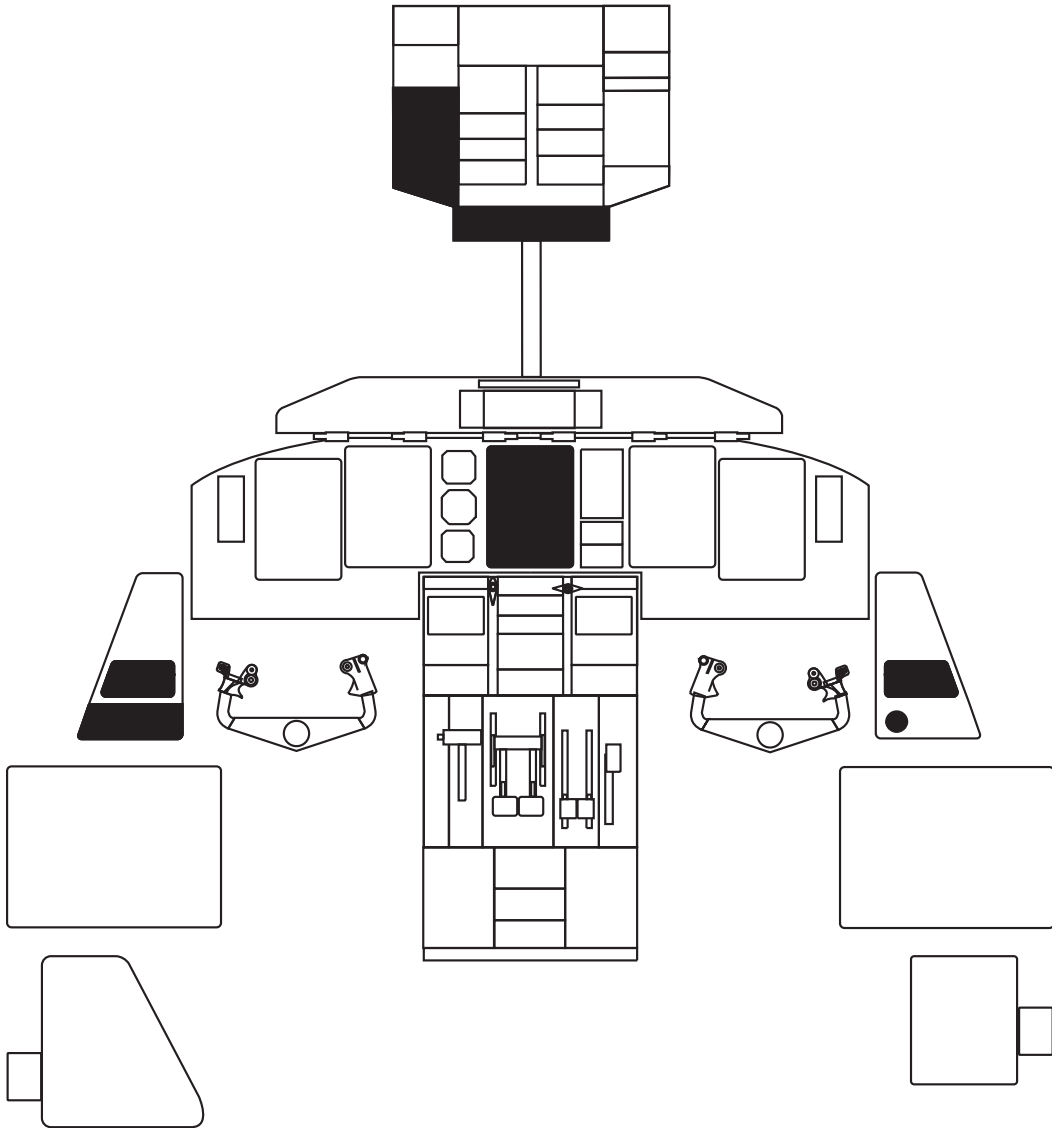

Figure 12.11-1 Airframe De-icing System Components

12.11.3 Controls and Indications - Ice and Rain Protection



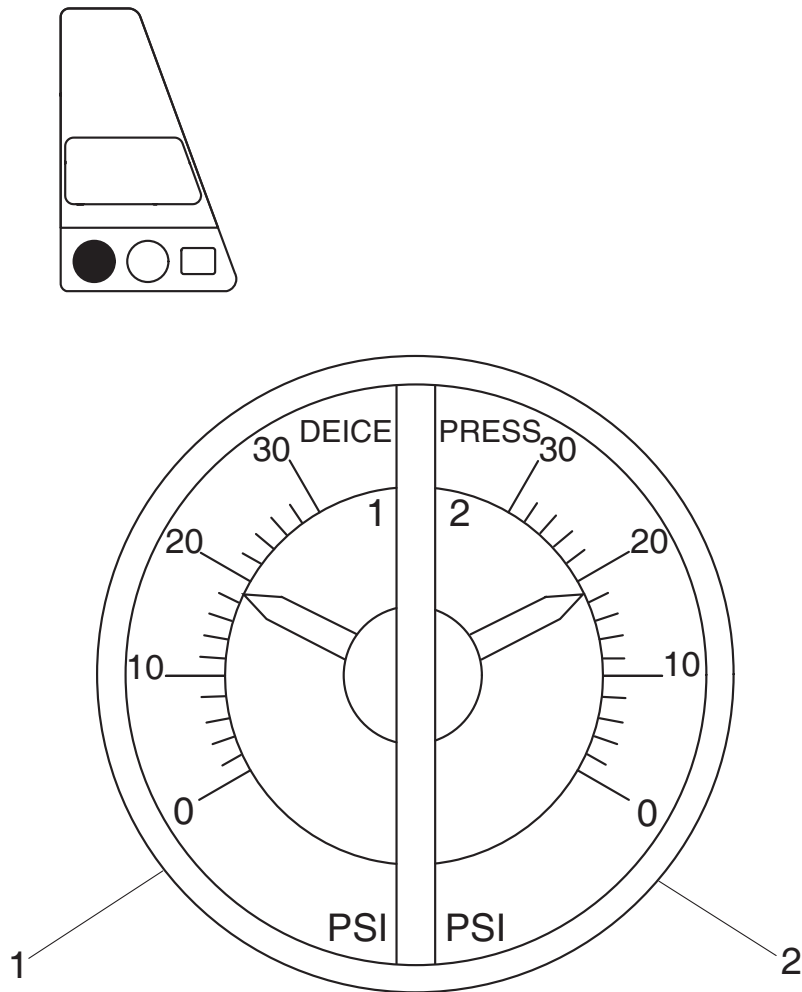

Figure 12.11-2 Airframe De-Ice Press Indicator

DE-ICE PRESS INDICATOR CALLOUT (copilot's side panel)

1. LEFT SIDE AIRFRAME DEICE PRESSURE GAUGE

- indicates pneumatic pressure in left system when BOOT AIR switch is in the ISO position (normally at 18 ± 3 psi)
- indicates average pneumatic pressure of left and right system when BOOT AIR switch is in the NORM position

2. RIGHT SIDE AIRFRAME DEICE PRESSURE GAUGE

- indicates pneumatic pressure in right system when BOOT AIR switch is in the ISO position (normally at 18 ± 3 psi)
- indicates average pneumatic pressure of right and left system when BOOT AIR switch is in the NORM position

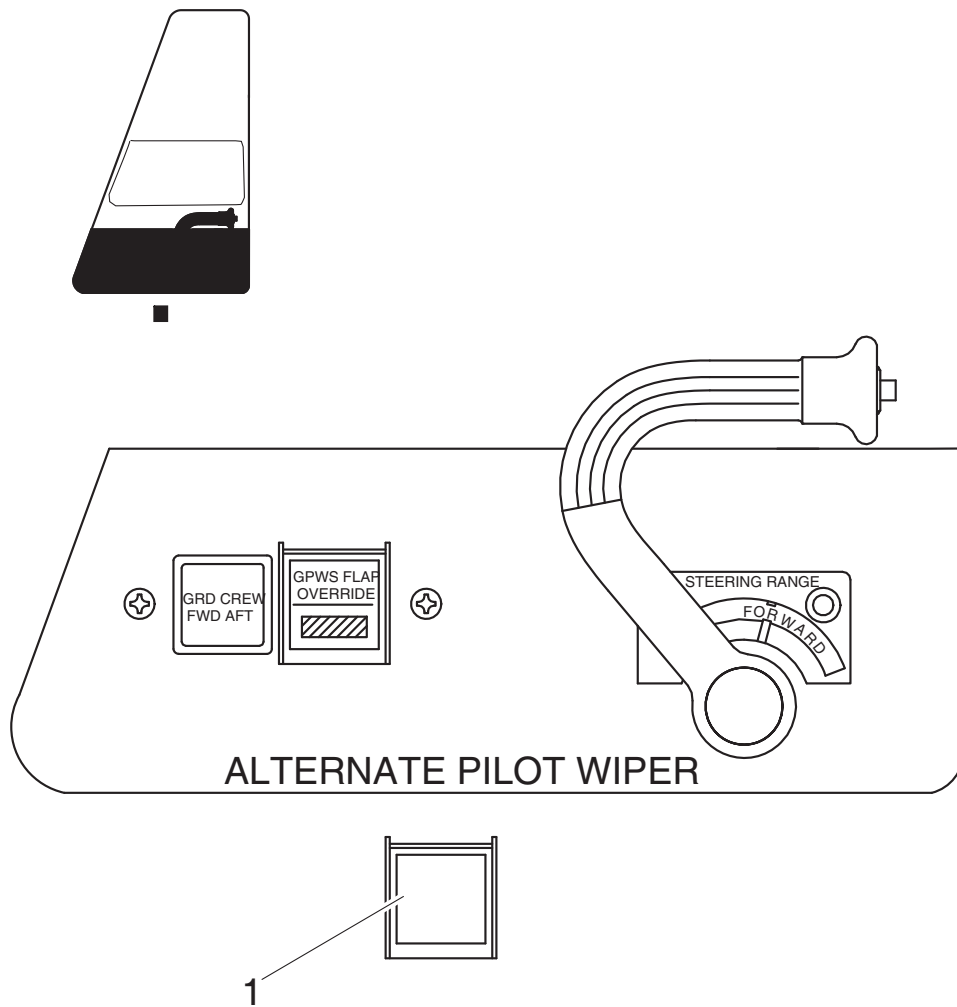

Figure 12.11-3 Alternate Pilot Wiper Switch

ALTERNATE PILOT WIPER CALLOUT

1. ALTERNATE PILOT WIPER PUSHBUTTON (guarded, alternate action)

PUSH - (in)

- pilot's windshield wiper operates at high speed

PUSH - (out)

- pilot's windshield wiper stops

Dash8 - Q400 - Ice & Rain Protection

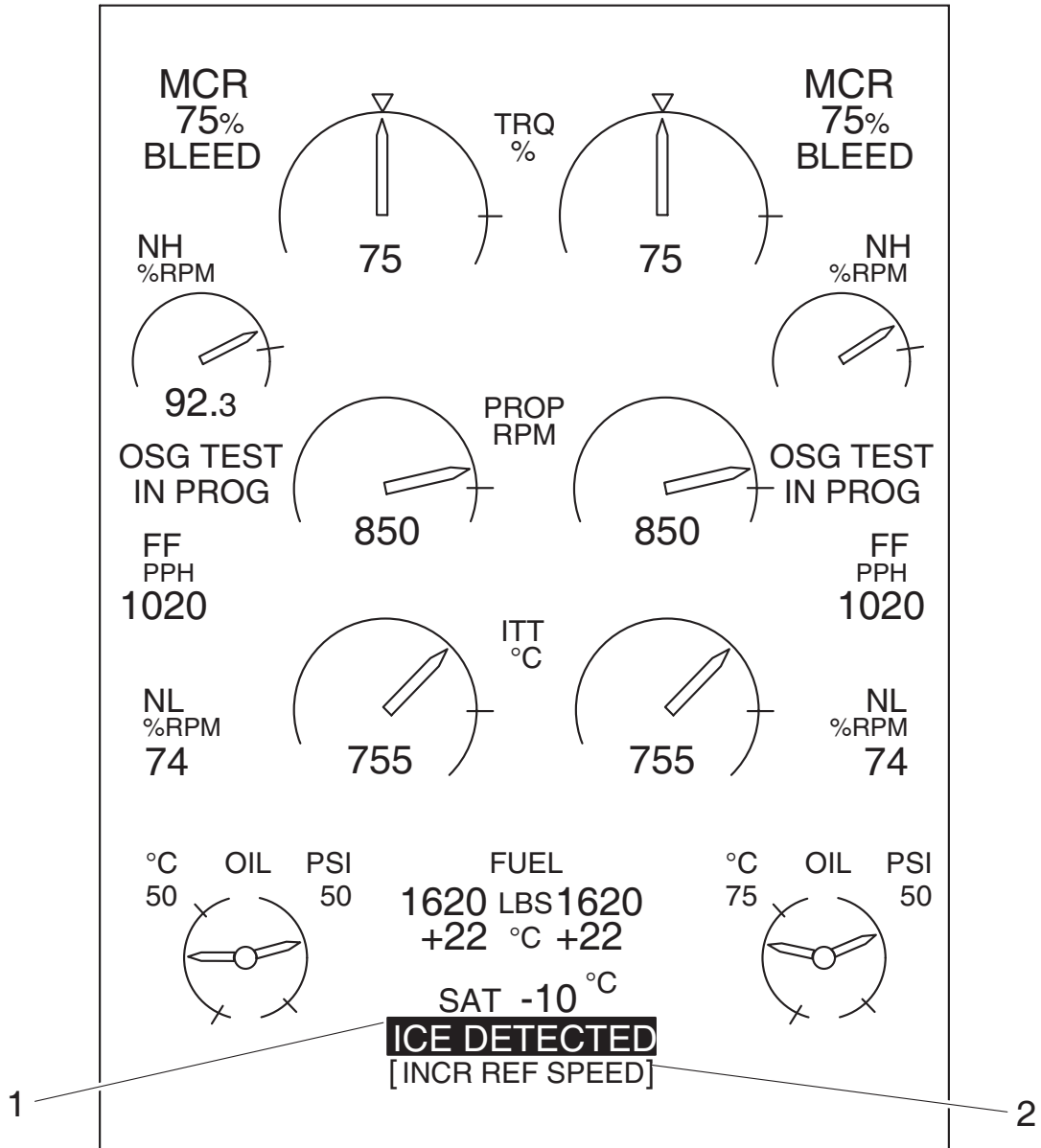
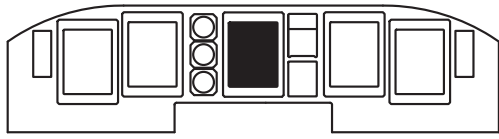

Figure 12.11-4 Engine Display (ED) Ice and Rain Parameters

ED CALLOUTS PERTAINING TO ICE AND RAIN PROTECTION

1. ICE DETECTED MESSAGE (flashing white, reverse video for the first 5 sec.)

- one or both ice detector probes have detected more than 0.5 mm of ice
- message will flash for 5 seconds, and if the REF SPEEDS switch is not set to the INCR position, message will continue in normal video

(white normal video, not flashing)

- aeroplane is in icing conditions with the REF SPEEDS switch set to the INCR position

2. [INCR REF SPEED] MESSAGE (white)

- REF SPEEDS switch set to INCR
- Stall Protection System (SPS) adjusts stall margin for icing conditions

Dash8 - Q400 - Ice & Rain Protection

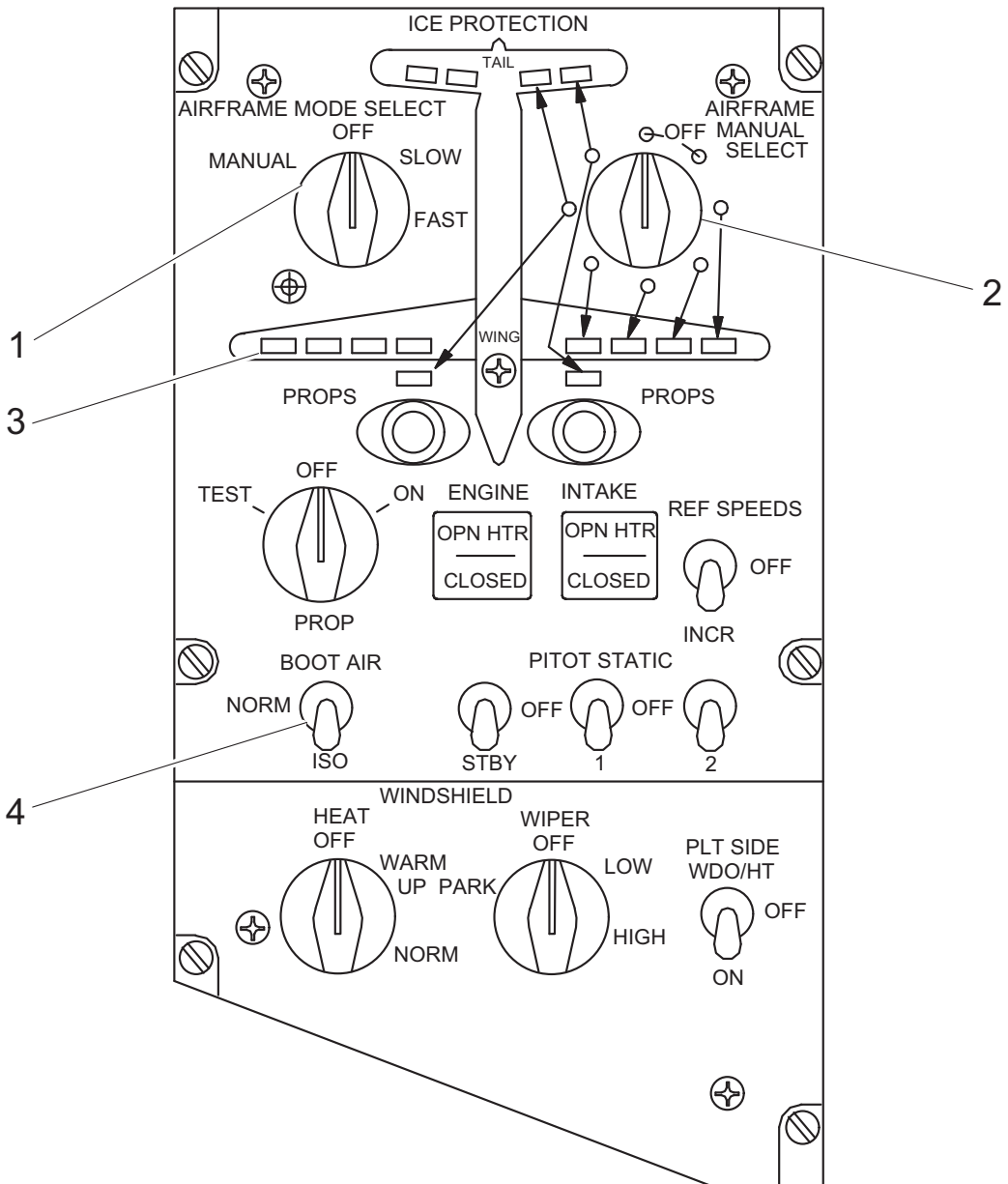
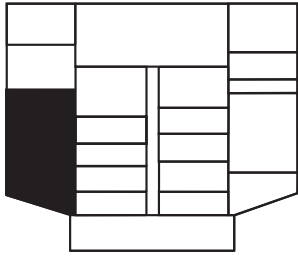

Figure 12.11-5 Ice-Protection Panel (1 of 4)

ICE PROTECTION PANEL CALLOUTS

1. AIRFRAME MODE SELECT SELECTOR (four position, rotary action)

OFF - automatic boot sequencer off

- Dual Distributor Valves (DDV) and check valve heaters Timer and Monitor Unit (TMU) controlled

SLOW - automatic sequencing of deice boots with 3 minute cycle (144 sec. dwell time)

FAST - automatic sequencing of deice boots with 1 minute cycle (24 sec. dwell time)

MANUAL - DDV and heated check valve heaters on manually

- boots can inflate with manual selection of DDV valves using AIRFRAME MANUAL SELECT switch

2. AIRFRAME MANUAL SELECT SELECTOR (eight position, rotary action)

OFF - (two positions)

- automatic sequencing of de-ice boots can be done

BOOT DETENT - (six positions)

- inflates related boots by energizing related DDV
- AIRFRAME MODE SELECT switch must be at OFF or MANUAL
- minimum dwell time of 24 seconds before inflating boots again

3. BOOT INFLATION ADVISORY LIGHT (green)

- related boot pressure is 15 psi or above

4. BOOT AIR SWITCH (two position toggle)

NORM - isolator shut off valve energized open

- left and right bleed air systems connected

ISO - isolator shut off valve closed

- left and right bleed air systems isolated from each other
- boots must be selected manually

Dash8 - Q400 - Ice & Rain Protection

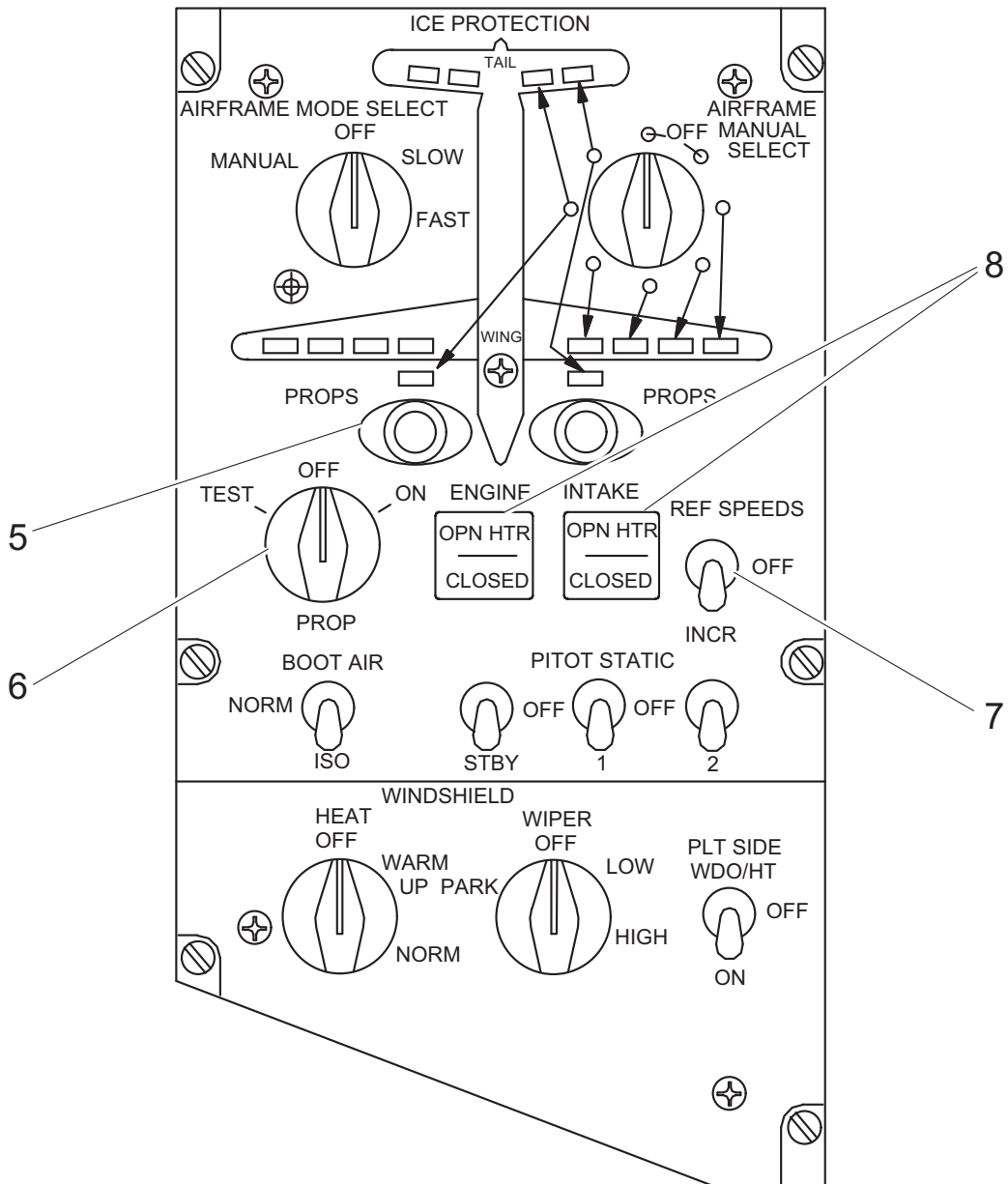
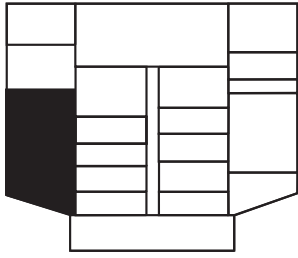

Figure 12.11-6 Ice-Protection Panel (2 of 4)

ICE PROTECTION PANEL CALLOUTS (cont'd)

5. PROPS ADVISORY LIGHT (green)

- all blade heater elements of related propeller are energized

6. PROP SELECTOR (rotary action)

TEST - each propeller will be heated separately for a cycle of 5 sec.

- N_P must be above 400 RPM (CL at MIN or greater)
- AC power must be available

OFF - propeller heaters not energized

ON - propeller heaters controlled by Timer Monitor Control Unit (TMCU)

- all blades on one propeller come on, then the other propeller is heated
- heating cycle is determined by TMCU using Total Air Temp (TAT) data
- temperature must be less than 5°C
- NP above 400 RPM (CL at MIN or greater)

7. REF SPEED SWITCH (two position toggle)

- [INCR REF SPEED] is shown on ED

8. ENGINE INTAKE SWITCHLIGHT (alternate action)

PUSH - OPN segment (amber)

- bypass door open

HTR - segment (amber)

- switchlight pushed
- OPN segment (amber)
- temperature less than 15°C
- engine oil pressure in operating range
- main or back up engine intake adapter heater energized

PUSH - CLOSED segment (green)

- bypass door closed
- engine intake adapter heater off (bypass door must be open for heater to operate)

Dash8 - Q400 - Ice & Rain Protection

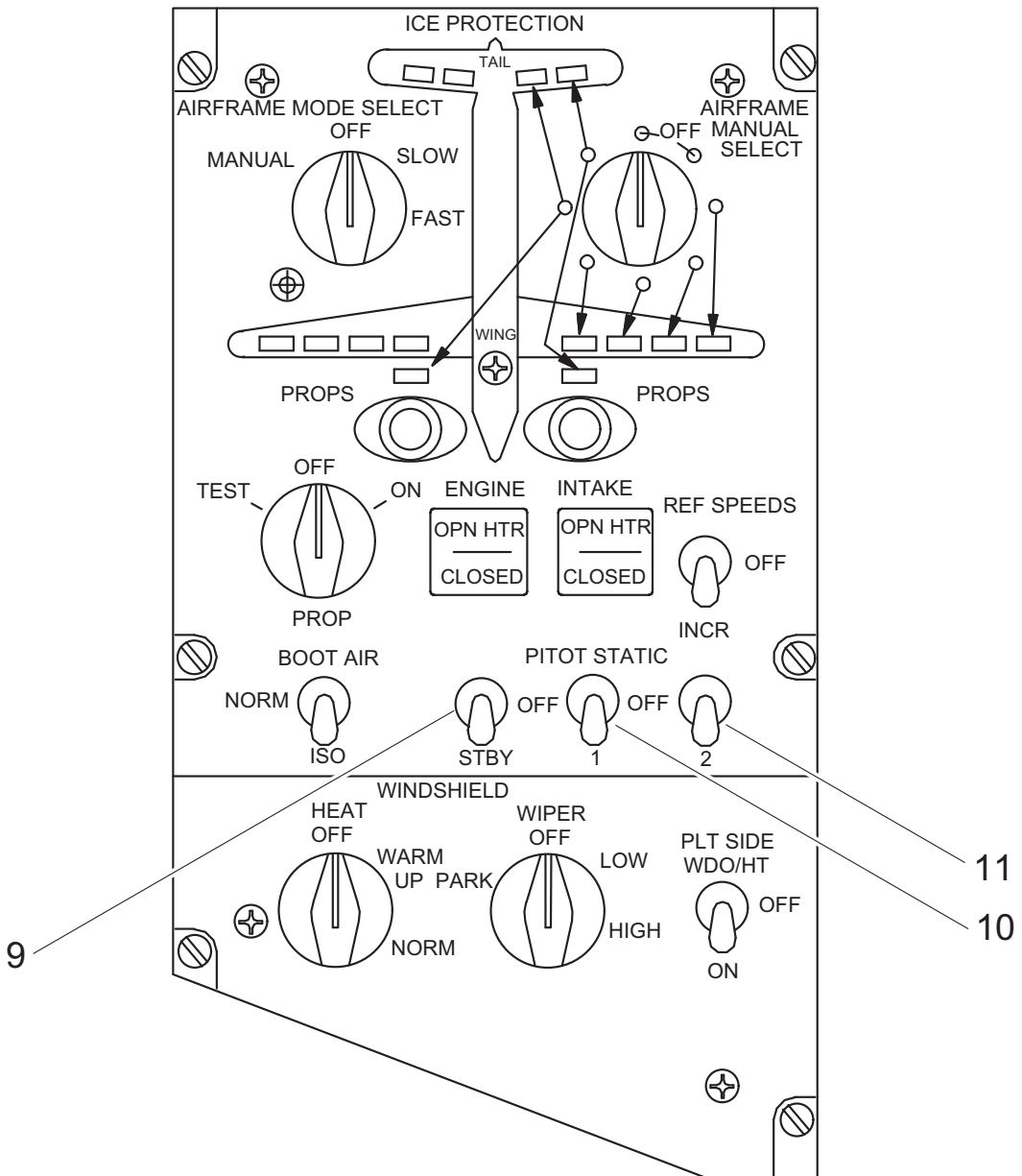
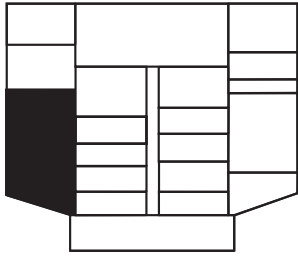

Figure 12.11-7 Ice-Protection Panel (3 of 4)

ICE PROTECTION PANEL CALLOUTS (cont'd)

9. STBY PITOT/STATIC PORT SWITCH (two position toggle)

OFF - standby pitot/static probe heater not energized

- PITOT HEAT STBY caution light comes on

STBY - standby pitot/static probe heater energized

- see that PITOT HEAT STBY caution light goes off

10. 1 PITOT/STATIC PORT SWITCH (two position toggle)

OFF - No. 1 pitot/static probe heater not energized

- PITOT HEAT 1 caution light comes on

1 - No. 1 pitot/static probe heater energized

- PITOT HEAT 1 caution light goes off

11. 2 PITOT/STATIC PORT SWITCH (two position toggle)

OFF - No. 2 pitot/static probe heater not energized

- PITOT HEAT 2 caution light comes on

2 - No. 2 pitot/static probe heater energized

- PITOT HEAT 2 caution light goes off

Dash8 - Q400 - Ice & Rain Protection

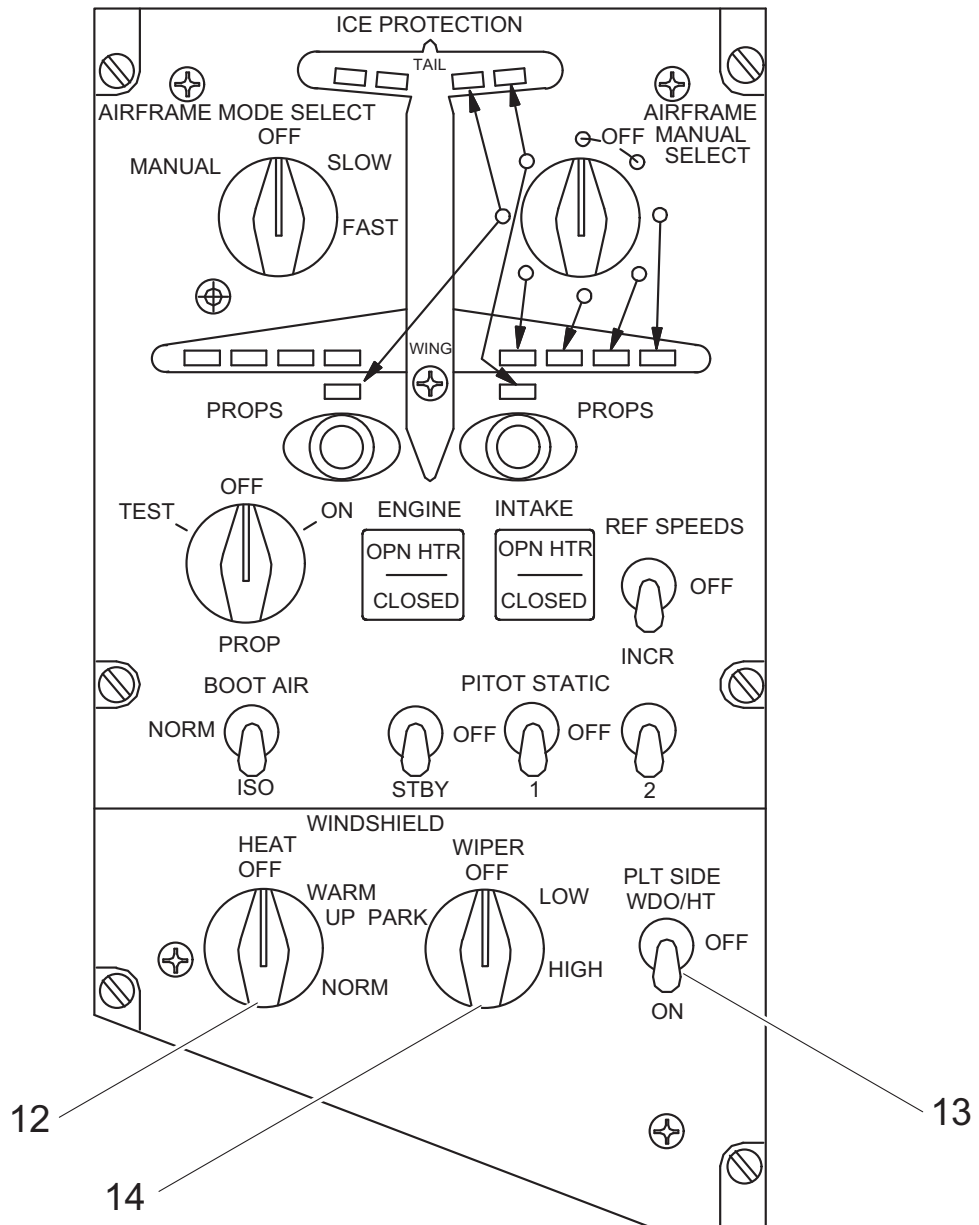
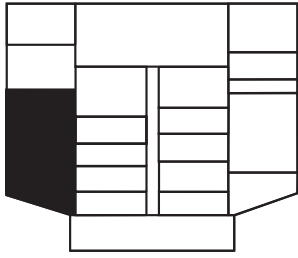

Figure 12.11-8 Ice-Protection Panel (4 of 4)

ICE PROTECTION PANEL CALLOUTS (cont'd)

12. HEAT SWITCH (rotary action)

OFF - both windshield heaters off

WARM UP - both windshields heated in series with power from 115 VAC left bus

- if preset threshold temperature is not reached in 5 min, WSHLD CTRL caution light comes on

NORM - pilot's windshield heated with power from 115 VAC left bus

- copilot's windshield heated with power from 115 VAC right bus
- if preset threshold temperature is not reached in 5 min, WSHLD CTRL caution light comes on
- windshield temperature controlled by separate Anti-Ice Controllers (AIC) using overheat sensor
- if windshield temperature is too hot, WSHLD HOT caution light comes on

13. PLT SIDE WDO/HT SWITCH (two position toggle)

OFF - pilot's side window heater off

ON - pilot's side window heated with power from 115 VAC right bus

- only forward part of pilot's side window is heated
- pilot's side window temperature controlled by right AIC using overheat sensor
- overheat relay opens if side window temperature is too hot and SIDE WDO HOT caution light comes on

14. WIPER SWITCH (rotary action with spring loaded position)

OFF - both windshield wipers stop at existing position

LOW - both windshield wipers operate at slow speed from two independent wiper motors

HIGH - both windshield wipers operate at high speed

PARK - (spring loaded position)

- both windshield wipers automatically stop at the lower outboard park positions

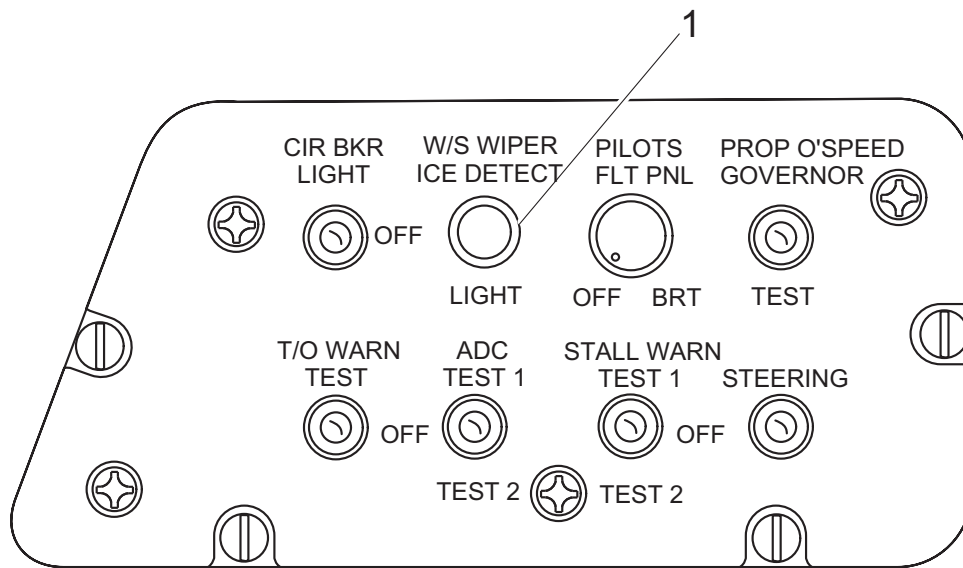
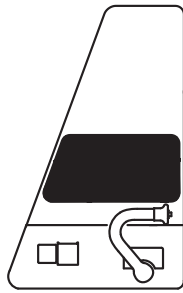

Figure 12.11-9 Pilot's W/S Wiper Ice Detect Pushbutton

PILOT'S SIDE PANEL CALLOUT PERTAINING TO ICE AND RAIN

1. W/S WIPER ICE DETECT PUSHBUTTON (momentary action)

PUSH - windshield wiper ice detection light, above glareshield, shines on the pilot's windshield wiper spigot

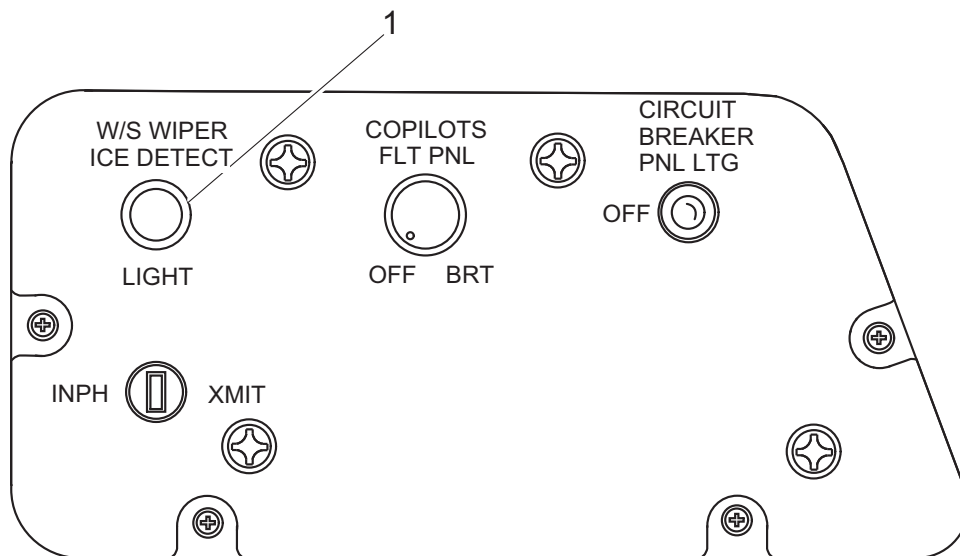
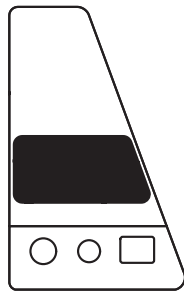
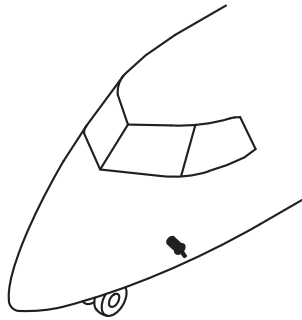

Figure 12.11-10 Copilot's W/S Wiper Ice Detect Pushbutton

COPILOT SIDE PANEL CALLOUT PERTAINING TO ICE AND RAIN

1. W/S WIPER ICE DETECT PUSHBUTTON (momentary action)

PUSH - windshield wiper ice detection light, above glareshield, shines on the copilot's windshield wiper spigot



NOTE

Left side shown.
Right side similar.

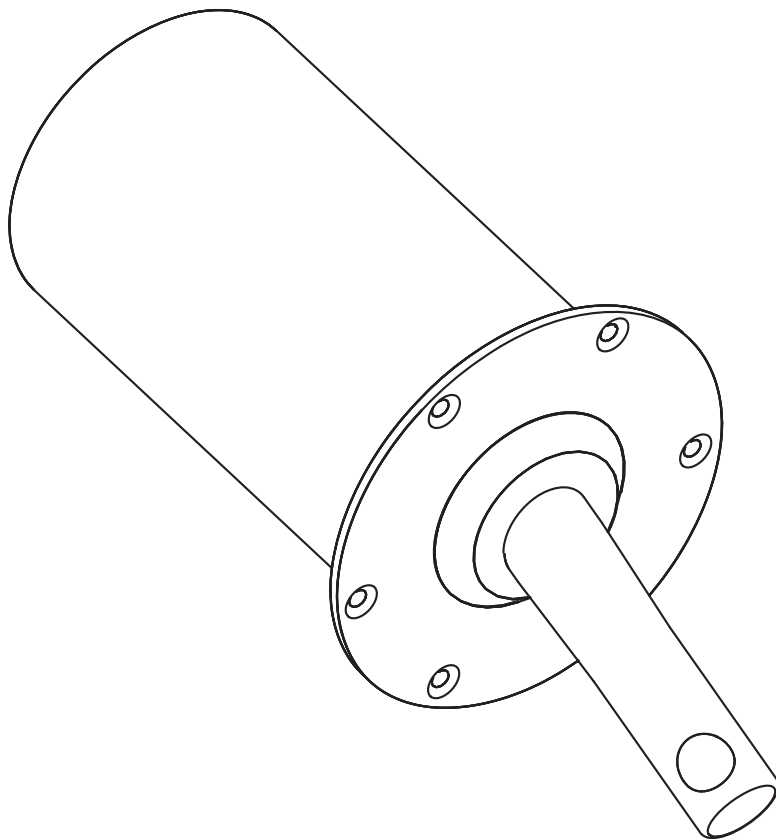

Figure 12.11-11 Ice Detector Probe

12.11.4 Ice Detection System

There is no flight deck control for the Ice Detection System (IDS). The system automatically operates as soon as 115 VAC power is available. The IDS uses two Ice Detector Probes (IDP) on the left and right side of the front fuselage (Figure 12.11-10). If either IDP detects more than 0.5 mm of ice, it is heated with power from the related 115 VAC bus. This deices the probe so that it can detect ice again.

If either IDP detects ice, an ICE DETECTED message will flash in white reverse video for 5 seconds, or until the PROP selector is set to the ON position. The message is shown on the ED just below the SAT indication. An [INCR REF SPEED] command message is shown in white just below the ICE DETECTED message when the Stall Protection System (SPS) is modified for icing conditions, as a result of turning the PROPs selector on.

The ICE DETECT FAIL caution light will come on if both ice detector probes fail. Failure of only one probe will not cause the caution light to come on, as the system is redundant.

12.11.5 Airframe De-icing System

Airframe de-icing can be controlled automatically or manually. Pneumatically actuated rubber de-icing boots are bonded to the leading edges of the wings, horizontal and vertical stabilizers, and nacelle inlet lips (Figure 12.11-11). De-icing bleed air is taken from the bleed port of each engine and is available to inflate the boots regardless of the position of BLEED control switches. System pressure is regulated to 18 psi and shown on the DEICE PRESS indicator, located on the copilot's side panel. An isolator valve interconnects the two systems. A BOOT AIR switch is used to control the isolator valve, which is normally open to ensure uninterrupted operation of either system if one engine is not operating. The ISO position can be used to check regulated pressure in each system individually or to isolate a system leak.

Regulated de-icer pressure is also used to inflate the forward passenger and aft baggage door seals, and to operate ejector for the pressurization system AFT safety valve.

The boots inflate, and stay inflated, with pressurized air when the Dual Distributing Valves (DDV) are energized open. When not activated, boot ports are connected to suction to deflate and hold the boots flush with the leading edges.

The AIRFRAME MODE SELECT rotary switch selects automatic de-icing, when set to SLOW (3 min.) or FAST (1 min.). The selector is self-homing such that a selection to SLOW or FAST and back to OFF will complete a full cycle. Automatic boot inflation sequence is controlled and monitored by the Timer and Monitor Unit (TMU) (Figure 12.11-11, 12.11-12). The TMU controls the sequence and supplies a dwell period related to the selected rate (Table 12.11-1). Green WING, TAIL and nacelle inlet lip boot inflation lights show boot inflation sequence and confirm correct boot inflation pressure.

NOTE: To make sure deice pressure is maintained at 15 psi or greater during decent, holding and approach, it may be necessary to increase N_L by advancing the POWER levers.

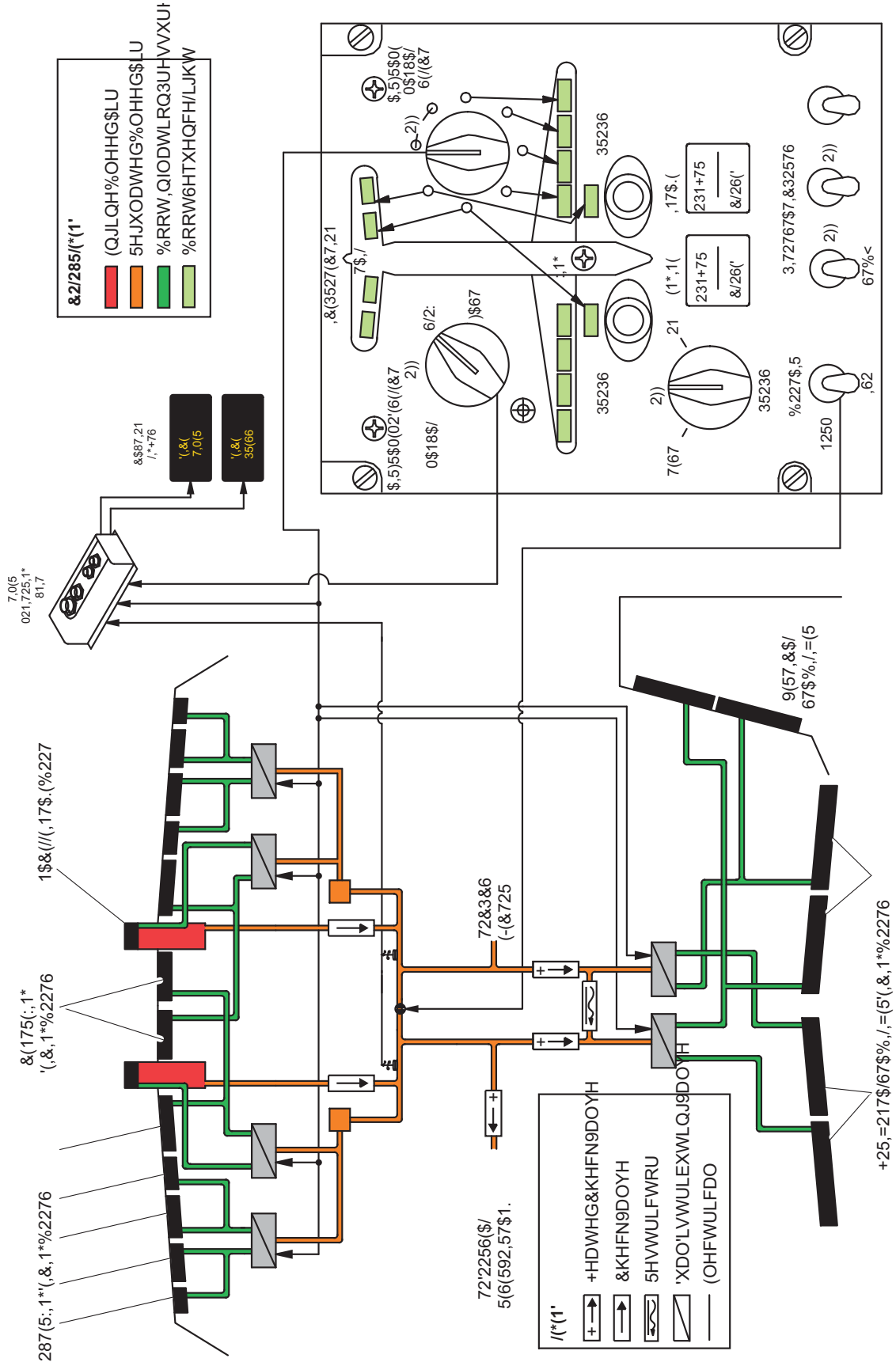
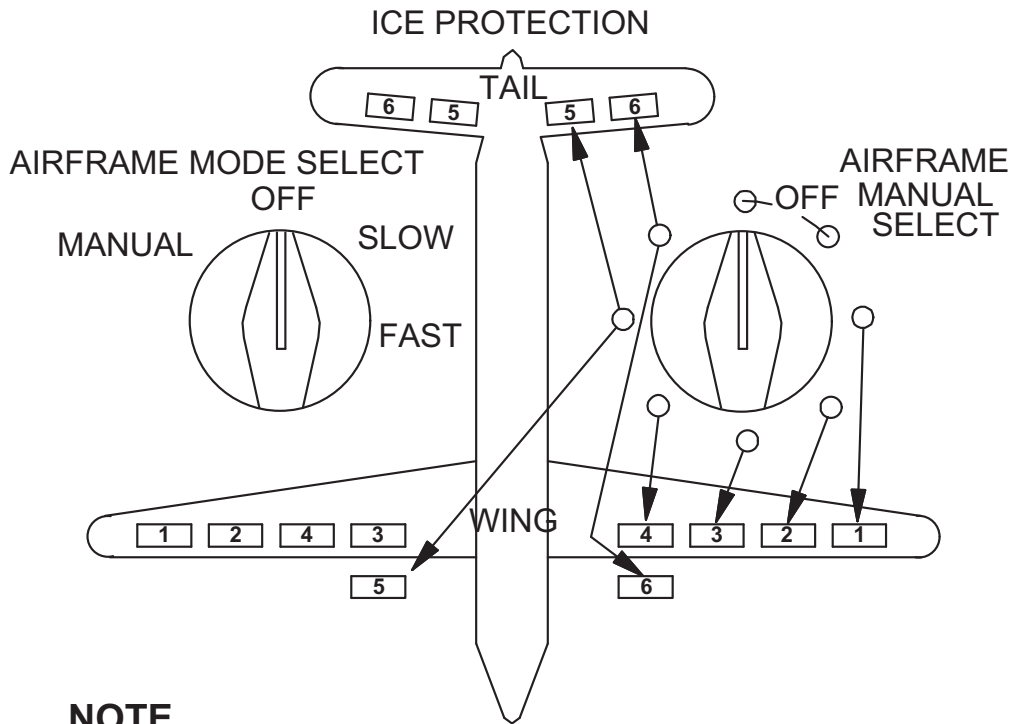

Figure 12.11-12 Airframe De-Icing Schematic



NOTE

Manual switch positions and related indicator light sequence correspond with deice boot inflation sequence shown below. Numbers do not actually appear on panel.

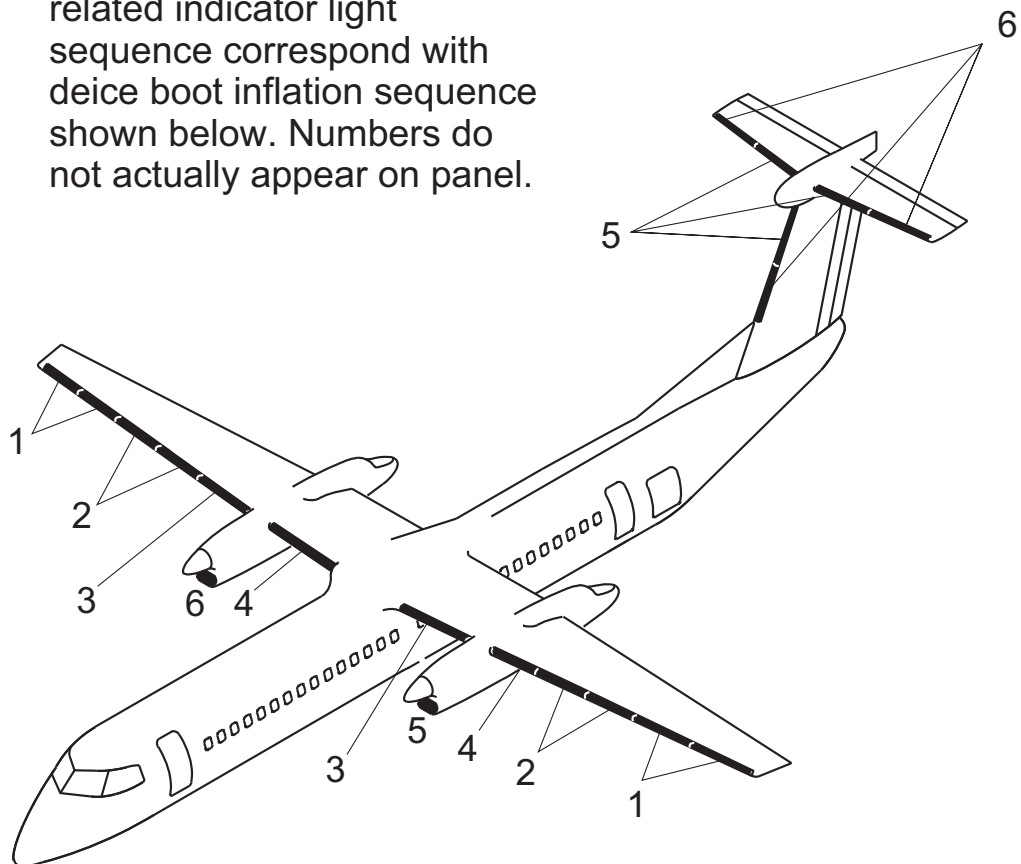

Figure 12.11-13 Airframe De-ice Boots Inflation Sequence and Lights

BOOT SEQUENCE		INFLATION TIME	DWELL TIME	
DISTRIBUTING VALVES	BOOT LOCATION		FAST	SLOW
1A & 2A	Extension and Outboard on Each Wing	6 Seconds for each combination of boots	24 Sec. between end of (6) and restart of (1)	144 Sec. (2 min + 24 Sec.) between end of (6) and restart of (1)
1B & 2B	Outboard Center and Inboard Center on Each Wing			
3B	Right Inboard and Left Center (Root)			
4B	Left Inboard and Right Center (Root)			
3A & 5A & 6A	Left Nacelle, Upper Vertical and Inboard Horizontal Stabilizers			
4A & 5B & 6B	Right Nacelle, Lower Vertical and Outboard Horizontal Stabilizers			

Table 12.11-1 Deicer Boot Operation Sequence

Integral DDV and check valve heaters automatically come on when the:

- TMU temperature monitor parameter has not failed
- AIRFRAME MODE SELECT switch set to OFF, SLOW or FAST
- Static Air Temperature (SAT) is less than +5°C.

If the TMU temperature monitoring parameter fails, the valve heaters stay on by default. If the TMU heater activation parameter fails, the valve heaters will not come on automatically. The DE-ICE TIMER caution light comes on if there is a failure of the TMU:

- automatic deice sequencer
- logic
- input disagreement

When the AIRFRAME MODE SELECT switch is set to the MANUAL position, the DDV and check valve heaters come on permanently and do not cycle.

Dash8 - Q400 - Ice & Rain Protection

If a malfunction occurs in the automatic timer or a leak occurs in the system, the boots can be cycled manually with the AIRFRAME MANUAL SELECT switch. Rotating the switch through each of the six detent positions duplicates the automatic inflation sequence. Each set of related boots will inflate as long as the switch stays at the set position. The related WING, TAIL and nacelle inlet boot inflation light come on to show full inflation. A minimum dwell time of 24 seconds should be observed before inflating the boots again.

NOTE: Each selection should be held until the corresponding pair of lights come on before moving to the next position.

If a rupture or leak occurs to the pneumatic lines of either deice system, the affected side will have to be isolated to ensure that deice pressure is available to the leakless side. When the BOOT AIR switch is set to ISO, the isolation shutoff valve closes. Isolating the failed side from the functioning pressure side. All the boots on the horizontal and vertical stabilizers are pneumatically cross connected to ensure boot pressure, even if one half of the system loses pressure.

The DE-ICE PRESS caution light will come on if the:

- main de-ice pressure on either side is less than 15 psi,
- boot pressure does not reach 15 psi after the DDV opens,
- boot pressure stays at 15 psi after the DDV closes.

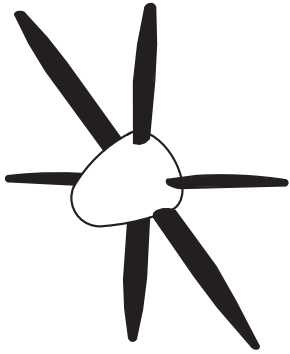

NOTE

One of six Prop Blades shown.
Other Prop Blades similar.

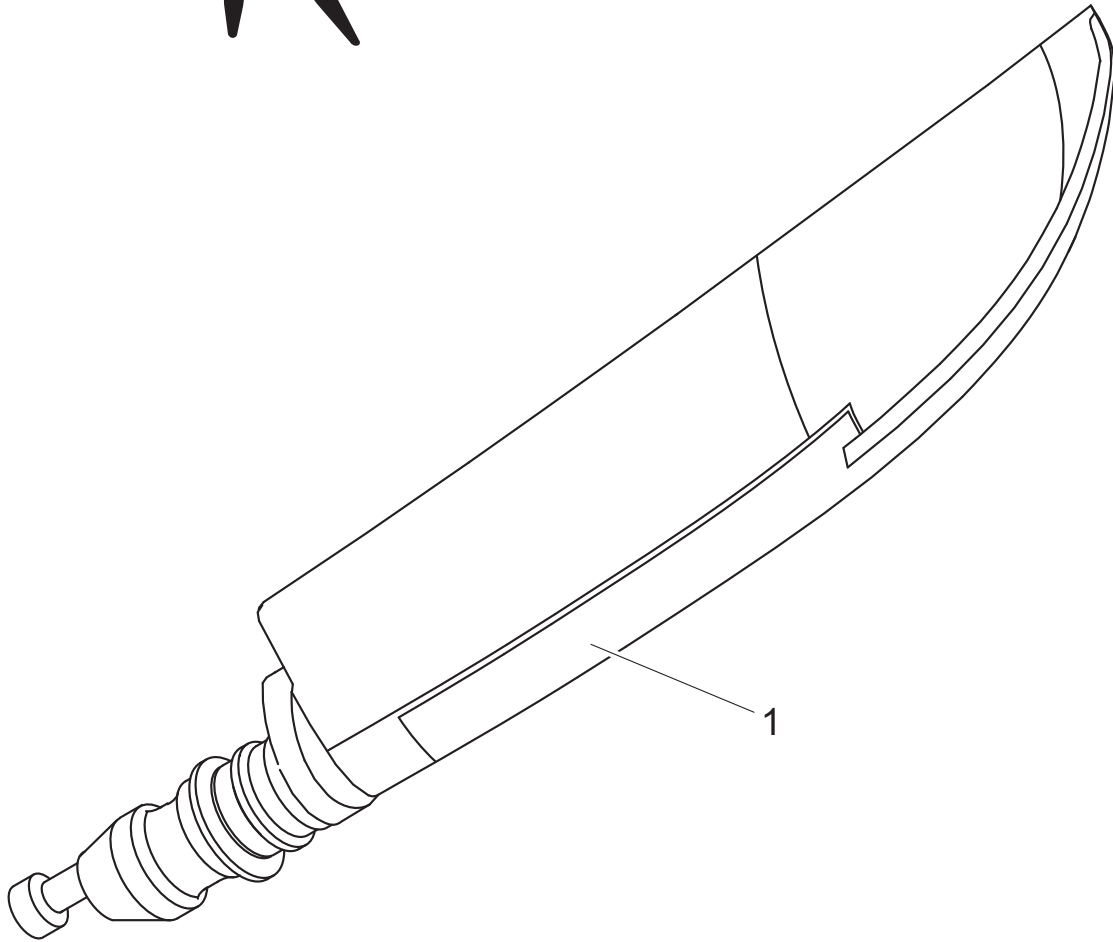

LEGEND

1. Heating Element (70% of Blade).

Figure 12.11-14 Propeller De-ice Heating Element

12.11.6 Propeller Heaters

The propeller blade leading edges are protected from ice accumulation by electrically heated elements bonded onto each blade (Figure 12.11-13). Electrical power is supplied from the related 115 VAC variable frequency bus.

The propeller deice system is operated by the PROPs selector. All six blades on one propeller are heated at the same time during a de-icing cycle. To minimize the electrical load on the system, one propeller is heated then the other propeller is heated. Two PROPs de-ice indicator lights, on the ICE PROTECTION panel, come on when the related propeller is heated. The heater cycle for each propeller is controlled by a related Timer Monitor Control Unit (TMCU). The TMCU heater cycle times depend on the Total Air Temperature (TAT) as shown in Table 12.11-2.

TAT/°C (average)	PROP HEATER	
	ON (SECONDS)	OFF (SECONDS)
> 5 (hold state)	OFF	–
-7 < TAT ≤ 5 (default mode)	12	78
-12 < TAT ≤ -7	45	80
-17 < TAT ≤ -12	74	76
-22 < TAT ≤ -17	84	96
TAT ≤ -22	92	108

Table 12.11-2 Propeller Heater Cycle Times

The Total Air Temperature, TAT, must be equal to or lower than 5°C for the propeller heaters to operate. TAT is always higher (warmer) than the Static Air Temperature (SAT) with the TAT increasing as the airspeed increases. Therefore, with an indicated SAT of approximately 5°C and a high airspeed, the propeller heaters may not cycle.

Note:

With observed ice accumulation, the propeller deice system should function regardless of the observed SAT.

The TMCU will heat all six blades of its propeller when the:

- PROP switch is set to ON
- TAT is less than or equal to +5°C
- N_p is above 400 RPM

When the PROP switch is set to the TEST position, each propeller will be heated separately for a cycle of 5 seconds, if NP is above 400 RPM. The propeller indicator lights will come on to confirm heater/timer operation. The test cannot be started again for 30 seconds to prevent overheating of

Dash8 - Q400 - Ice & Rain Protection

the blade elements. Fuselage ice protection panels, installed on both sides of the fuselage adjacent to the propeller arc, prevent damage to the fuselage from ice thrown by the propellers.

Note:

The effectiveness of the propeller de-icing system can be improved and propeller vibration reduced by operation of the propellers at 1020 RPM (CL at max).

If there is a failure of the propeller de-icing system, the PROP DEICE caution light will come on.

12.11.7 Engine Intake Heaters/Bypass Doors

An electric heater is installed in the intake flange of each engine. The heaters are powered by 115 VAC variable frequency and are energized when the engine intake bypass doors are opened. An oil pressure switch and temperature sensor in the heater control circuit prevents heater operation when the engine is shutdown and/or air temperature is above +15°C. Heater operation is confirmed by the HTR segment on the ENGINE INTAKE switchlight coming on when the doors are opened.

The engine intake heaters are controlled by thermostates, attached internally to the fuselage skin below the pilot's seat. The thermostat mechanical switch close at an Outside Air Temperature of 15+/- 2 degrees C, and opens when OAT is 1-3 degrees C above 15+/- 2 degrees C.

Since the thermostates are installed internally to the fuselage skin they reacts to the skin temperature and not to actual SAT.

Therefore in summerperiod, depending of the time the a/c has been on ground and weather conditions it is fully normal that the engine intake heaters do not turn on during climb at a SAT of 15 degrees C.

12.11.8 Pitot/static Probe Heat

The No. 1, No. 2 and standby pitot/static probes (Figure 12.11-14 and 12.11-15) incorporate integral heaters which are activated by the flight crew to prevent ice build up. The No.1 pitot/static probe heater is powered from the left 115 VAC C phase Left bus, and the No. 2 probe is powered from the right 115 VAC C phase Right bus. The standby pitot/static probe heater is powered from the 28 VDC Right Essential bus. All three pitot/static probes are controlled and monitored by separate modules of the TMU, controlled by the PITOT/STATIC PROBE switches on the ICE PROTECTION panel.

The PITOT HEAT STBY, 1, and 2 caution lights come on when the related probe heater is inoperative or when the related PITOT/STATIC PROBE switch is set to the OFF position.

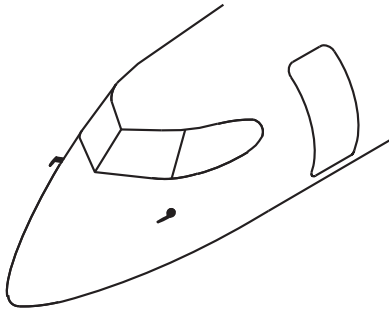

NOTE

Left component shown.
Right component similar.

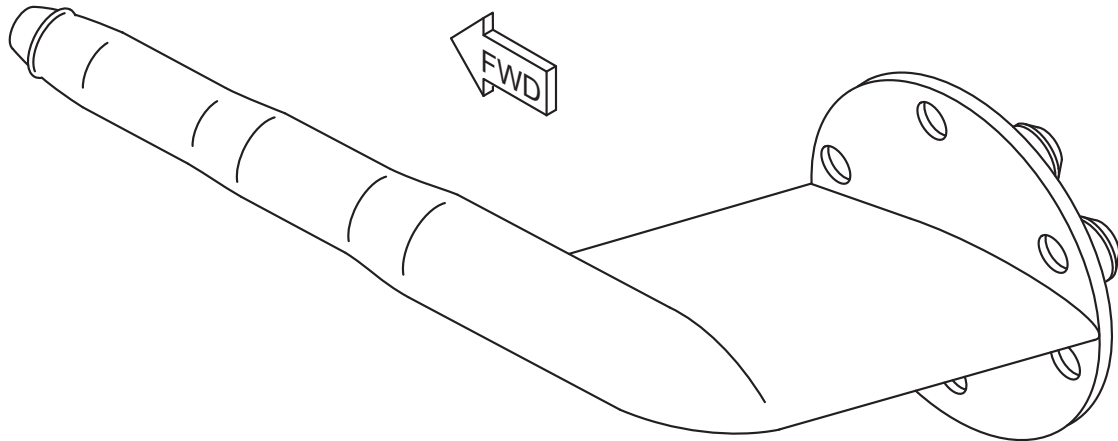

Figure 12.11-15 Pilot's and Copilot's / Static Probe

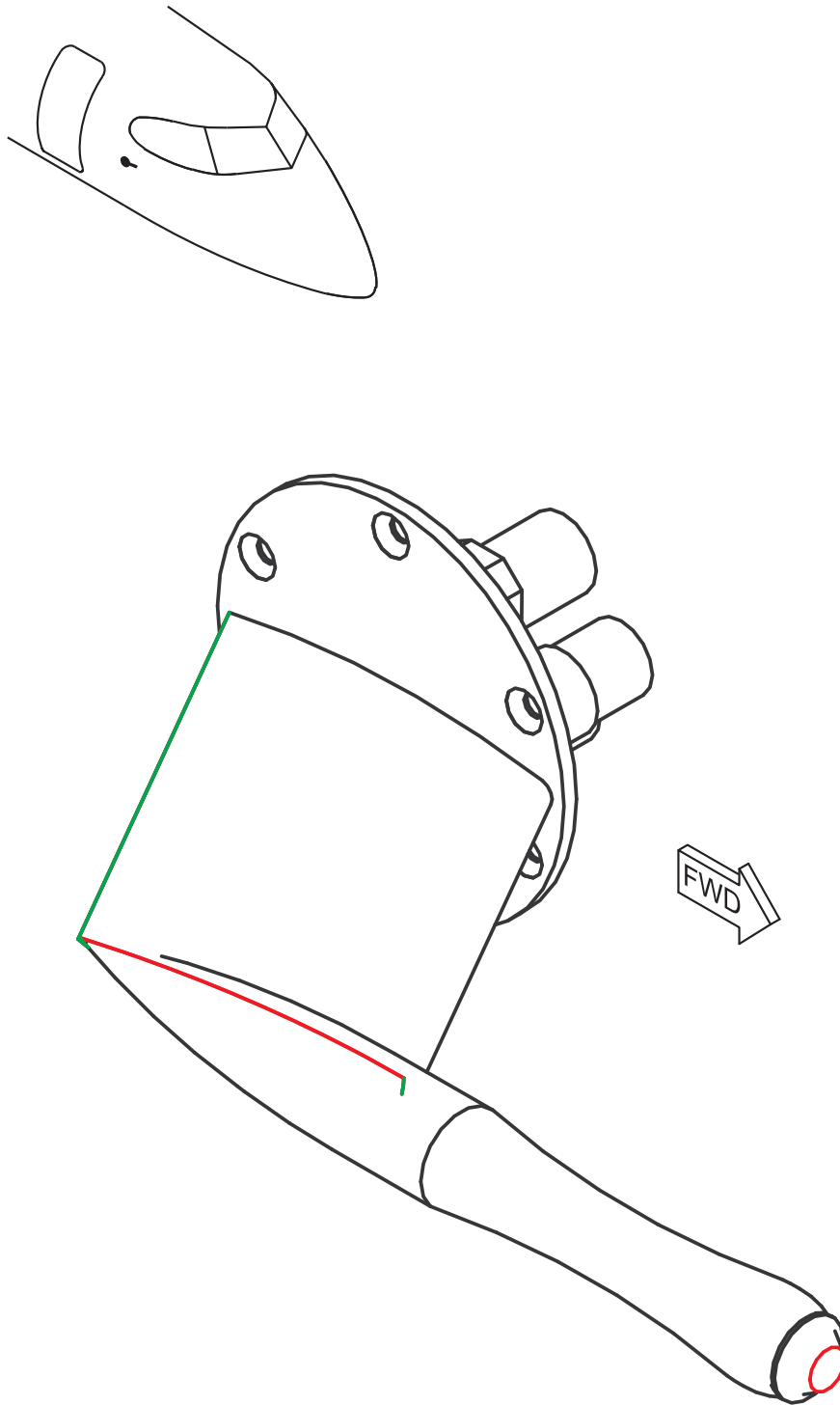
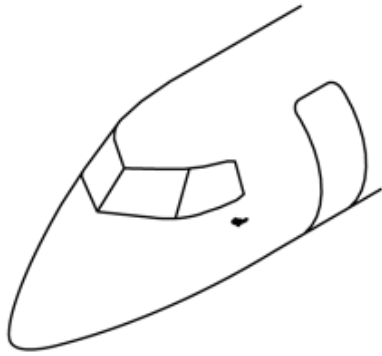

Figure 12.11-16 Standby Pitot Static Probe

Dash8 - Q400 - Ice & Rain Protection



NOTE
Left side shown.
Right side similar.

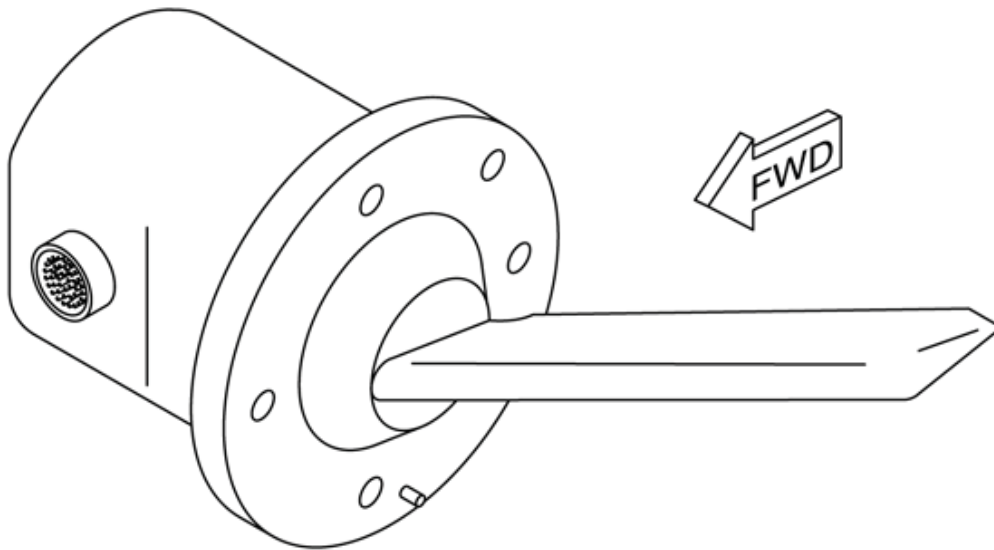

Figure 12.11-17 AOA Vane

12.11.9 AOA Vane Heaters

There is no flight deck control for the Angle of Attack (AOA) vane (Figure 12.11-16) heaters. The left and right AOA vanes are heated to prevent ice build up whenever variable 115 VAC power is available. The left AOA vane is powered from the left 115 VAC B phase Left bus, and the right AOA is powered from the right 115 VAC B phase Right bus. The AOA vane heaters are directly connected to their power supply through the TMU.

There is no direct caution light for an AOA heater failure. If the Stall Protection Module (SPM) senses an AOA heater failure, it causes the PUSHER SYS FAIL caution light to come on, and the applicable STALL SYS FAIL caution light.

12.11.10 Windshield And Pilot's Window

The left and right windshields and the pilot's side window are heated to supply anti-icing and demisting. When the WINDSHIELD HEAT selector is set to WARM UP, both windshields are heated at half power from the left 115 VAC bus. When the selector is set to NORM, each windshield is heated at full power from its related 115 VAC bus. When the PLT SIDE WDO/HT toggle switch is set to ON the forward part of the pilot's side window is heated from the right 115 VAC bus.

Anti-ice controllers control the windshield and side window heaters. If either windshield controller fails, the WSHLD CTRL caution light comes on. If either windshield overheats, the WSHLD HOT caution light comes on. If the pilot's side window overheats, the SIDE WDO HOT caution light comes on. An overheat condition also shuts off power to the related windshield or side window heater.

12.11.11 Windshield Wipers

Each windshield is equipped with a wiper and is controlled simultaneously from a single WIPER switch on the WINDSHIELD control panel, with positions PARK, OFF, LOW and HIGH. Selection from LOW or HIGH to OFF stops the blades at their existing position.

When the switch is set and held at the spring-loaded PARK position, the blades resume operation at low speed until stopped at the parked position. An ice detector spigot is installed on each windshield wiper arm for determining the amount of ice accumulation. Momentary W/S WIPER ICE DETECT pushbuttons, one on each side console, are used to light both spigots in dark conditions.

The ALTERNATE PILOT WIPER pushbutton, located on the pilot's side panel, provides back-up capability of activating the pilot's side windshield wiper.